

1  
2  
3  
4  
5  
6  
7  
8  
9  
10  
11  
12  
13  
14  
15  
16  
17  
18  
19  
20  
21  
22  
23  
24  
25  
26  
27  
28  
29  
30  
31  
32  
33

# Welcome to our interactive version of **Nitrogen+Syngas** Issue 374

Please use either the buttons on the left or top right of the page to navigate your way around this interactive PDF

#### IMPORTANT INFORMATION:

Copyright – Issued six times per year, or bi-monthly. All rights reserved. No part of this publication may be reproduced, stored in a retrieval system or transmitted in any form or by any means – electronic, mechanical, photocopying, recording or otherwise – without the prior written permission of the Copyright owner.

Number 374

November | December 2021

# nitrogen + syngas

www.nitrogenandsyngas.com

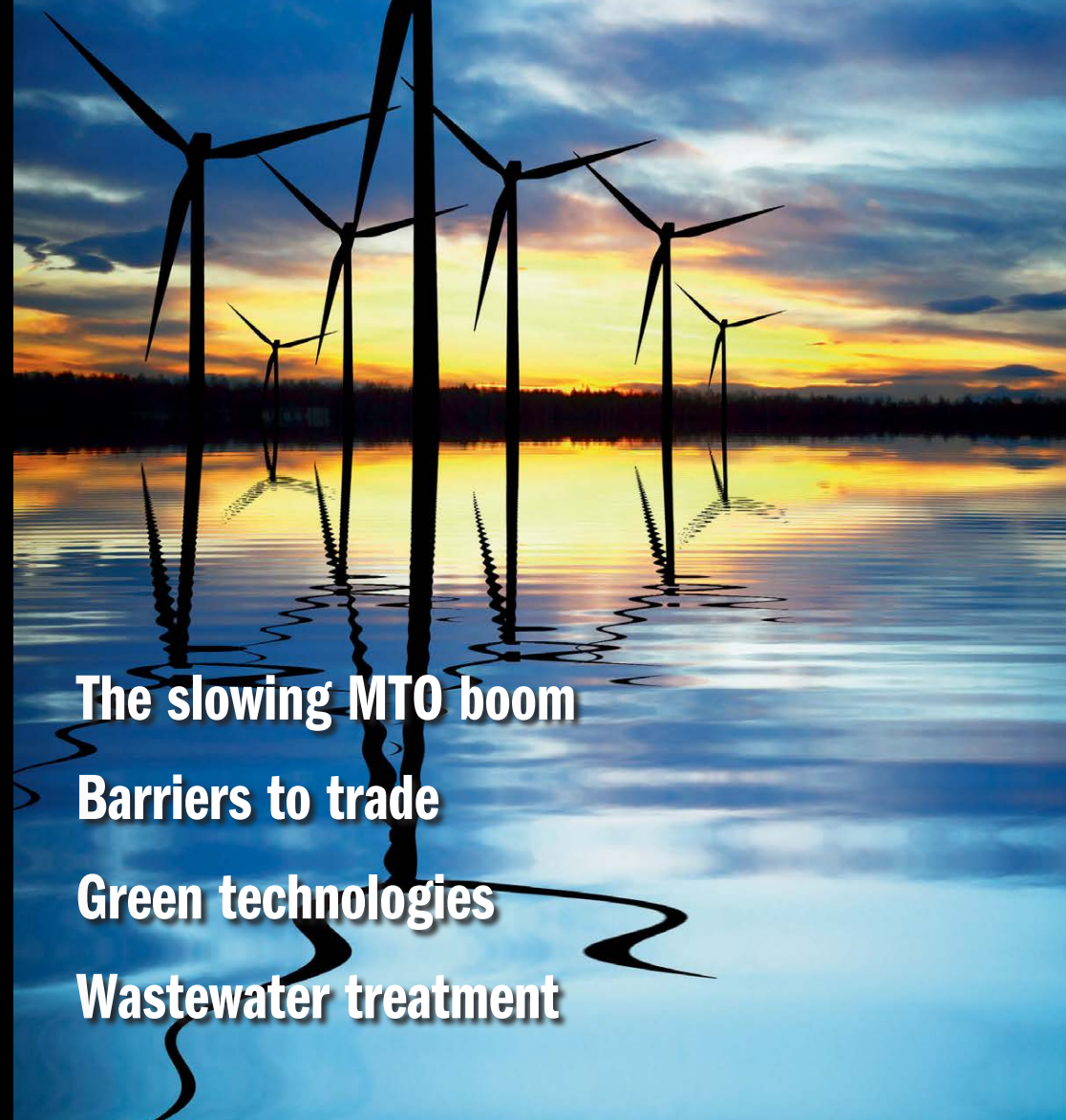

## The slowing MTO boom

## Barriers to trade

## Green technologies

## Wastewater treatment



CONTENTS

What's in issue 374

COVER FEATURE 1

The slowing MTO boom

COVER FEATURE 2

Barriers to trade

COVER FEATURE 3

Green technologies

COVER FEATURE 4

Wastewater treatment

NITROGEN+SYNGAS  
**ISSUE 374**  
NOVEMBER-DECEMBER 2022

## BCInsight

Southbank House, Black Prince Road  
London SE1 7SJ, England  
Tel: +44 (0)20 7793 2567  
Fax: +44 (0)20 7793 2577  
Web: www.bcinsight.com  
www.bcinsightsearch.com

# JM

## Optimise your methanol production with JM-LEVO

Managing your plant operations and methanol production as conditions change can be a challenge.

The JM-LEVO™ Methanol Portal provides you with the tools to efficiently monitor, adapt and optimise your processes in line with changing priorities and business requirements. The Portal demonstrates our commitment to make methanol production simpler for producers and operators worldwide.

The portal was built after listening and understanding the key challenges faced by methanol producers. It allows you to:

- Improve your understanding of your plant operation
- Achieve your targets such as increased production or improved efficiency
- Spend less time gathering and manipulating data
- Have more time with JM experts on focused, technical conversations
- Increase safety standards through early identification of developing issues
- Improve turnaround planning from better catalyst modelling

Please contact us at [JMLevo@matthey.com](mailto:JMLevo@matthey.com) for more information or visit our website at [www.matthey.com/levo-methanol](http://www.matthey.com/levo-methanol).

Available for general release Spring 2022

**Johnson Matthey**  
Inspiring science, enhancing life

[www.matthey.com](http://www.matthey.com)



Cover: Pati Photo/Shutterstock.com



### Methanol markets

Chinese ethylene capacity impacts upon MTO demand.



### Green technology

Reducing the carbon intensity of syngas production.

Read this issue online at:  
[www.nitrogenandsyngas.com](http://www.nitrogenandsyngas.com)

Published by:  
**BCInsight**

# nitrogen + syngas

[www.nitrogenandsyngas.com](http://www.nitrogenandsyngas.com)

NUMBER 374  
NOVEMBER | DECEMBER 2021

## CONTENTS

- 12 Chinese ethylene capacity slows the MTO boom**  
In China, requirements for methanol to produce olefins, mainly propylene and ethylene, from coal, has driven much of the growth in global methanol demand over the past decade. However, a new wave of ethylene cracker investment may put a stop to new MTO plant building.
- 14 Barriers to trade**  
With globalisation seemingly in retreat, the protectionist impulse is seeing a rise in barriers to trade, from quotas and tariffs to anti-dumping actions and domestic subsidies.
- 15 Modular plants**  
A move towards smaller scale feedstocks such as renewable energy and waste and biomass gasification is leading to increased focus on improving the efficiency of small-scale, modular plants.
- 16 Green technology progress for a more sustainable future**  
Casale, Linde, thyssenkrupp Industrial Solutions, Toyo Engineering Corporation, Haldor Topsoe and Stamicarbon report on some of their latest green technology developments to reduce carbon footprint in the synthesis of ammonia, methanol and hydrogen.
- 24 On the lookout for gas leaks**  
Scanfeld™ is the world's first remote sensing solution for fully automated early-warning gas leak detection for chemical plants. René Braun of Grandperspective discusses how the system works and how it is being applied in industry.
- 26 Redefining the sustainability of effluent treatment processes**  
Nitrogen-rich wastewaters remain a major issue for fertilizer and other industries. Saipem's new electrochemical technology, SPELL, is an important step towards the overall objective of zero industrial pollution.
- 29 Wastewater treatment in a urea plant**  
A detailed rain and wastewater concept is an important part of a urea plant to meet current stringent environmental standards. Wastewater can originate from the process reaction or from outside the process equipment. Wastewater treatment concepts from thyssenkrupp Industrial Solutions and Toyo Engineering Corporation are described.

## REGULARS

- 3 Editorial** The shape of things to come?
- 4 Price Trends**
- 4 Market Outlook**
- 5 Nitrogen Industry News**
- 8 Syngas News**
- 10 People/Calendar**
- 11 Plant Manager+** Problem no. 63: Holding reactor content during a long shutdown

CONTENTS

What's in issue 374

COVER FEATURE 1

The slowing MTO boom

COVER FEATURE 2

Barriers to trade

COVER FEATURE 3

Green technologies

COVER FEATURE 4

Wastewater treatment

NITROGEN+SYNGAS  
**ISSUE 374**  
NOVEMBER-DECEMBER 2022

**BCInsight**

Southbank House, Black Prince Road  
London SE1 7SJ, England  
Tel: +44 (0)20 7793 2567  
Fax: +44 (0)20 7793 2577  
Web: [www.bcinsight.com](http://www.bcinsight.com)  
[www.bcinsightsearch.com](http://www.bcinsightsearch.com)



# The shape of things to come?



Global nitrogen and methanol markets are currently in the grip of a crisis in feedstock prices. Mostly this is about Europe's dependence on imported natural gas, but – particularly on the methanol side – it has also been exacerbated by high coal prices in China, where heavy rains have led to flooding in Shanxi province, the source of one third of China's coal. These have followed similar floods in Henan in July, and come at a time when China is facing power rationing due to a lack of electricity supply. The world economy's long-awaited bounce back from the covid pandemic has also led to a general global surge in energy demand, and consequently higher oil and gas prices.

These are mostly temporary disruptions, but arguably Europe's issues are more long term and structural. Falling gas production in the North Sea and a switch away from nuclear energy and coal-fired power for environmental reasons has left Europe ever more dependent on imported natural gas supplies; either shipped in as LNG or piped across from Algeria, Norway, but above all Russia. Relying on LNG supplies means Europe must bid against the energy-hungry markets of Asia; Japan, China, and India, and at times of shortage, such as now, that often means being outbid. Meanwhile, relying upon Russia and its mercurial president Putin offers a different set of risks. Europe already has long experience of Russia's use of gas as an economic weapon in its long struggle for dominance over Ukraine, with gas supplies to Ukraine, and hence Europe, being cut off in 2005 and 2008. Consequently, pipelines have been constructed to bypass Ukraine, but the most recent one, a major expansion of the Baltic Nordstream pipeline, remains controversial in Europe, and some have suggested that delays over its certification have caused Russia to apply pressure again via gas supplies, at least in part causing the present crisis.

Europe hopes that in the longer term it will rid itself of this dilemma by large scale decarbonisa-

tion. The continent already produces 35% of its electricity from solar, wind and hydro-electric power. But it is prone to cold winters when energy demand for heating is high and available hours of sunlight are low. When the wind doesn't blow – something that has been the case this summer – other means must be used to keep the lights on. The UK saw wind provide only 7% of power generation in September compared to a normal average of 25%, and had to switch its last coal-fired power station back on to make up the shortfall.

A glance at the news section of this and the previous few issues of the magazine will quickly show the extent to which the syngas industries are aiming to move towards green power as a source of hydrogen. This potentially decouples them from increasingly volatile global gas markets, but does instead make them reliant on the vagaries of renewable power. That may be fine for a Middle Eastern producer where hours of sunlight are relatively reliable, but potentially difficult for northern hemisphere producers who are relying on wind. It does make me wonder whether we could one day be seeing renewable feedstock volatility in ammonia and methanol markets rather than gas and coal price swings, and speculate exactly how much storage might be required to even that out.

In the meantime, let's hope for a mild winter. ■

Richard Hands, Editor

## Euromel® Melamine The industry benchmark

24 plants worldwide. 5 million tonnes produced. No pollution. Euromel® is the world's leading melamine technology. Over the last 40 years, Eurotecnic has transformed the melamine market into a global operation by creating a melamine process that turns its Urea feedstock into a product that is profitable and in high demand.

Today, 24 melamine plants around the world have been licensed and implemented on the basis of Euromel®, with a combined annual capacity of more than 860,000 tons. Euromel® has also become the process with the lowest OPEX in the industry with zero-pollution, low energy consumption and no chemicals added for purification. Therefore investing in Euromel® means gaining access to a sustainable technology with a global network of producers.

Contact us at [www.euromel.com](http://www.euromel.com) to find out more.

EUROMEL®

[www.euromel.com](http://www.euromel.com)

EUROTECNICA  
MAKING SUSTAINABILITY PROFITABLE

CONTENTS

What's in issue 374

COVER FEATURE 1

The slowing MTO boom

COVER FEATURE 2

Barriers to trade

COVER FEATURE 3

Green technologies

COVER FEATURE 4

Wastewater treatment

NITROGEN+SYNGAS  
ISSUE 374  
NOVEMBER-DECEMBER 2022

BCInsight

Southbank House, Black Prince Road  
London SE1 7SJ, England  
Tel: +44 (0)20 7793 2567  
Fax: +44 (0)20 7793 2577  
Web: [www.bcinsight.com](http://www.bcinsight.com)  
[www.bcinsightsearch.com](http://www.bcinsightsearch.com)

# Price trends

Market insight courtesy of Argus Media

## NITROGEN

Several traders have struggled to export urea from China during October, and it is clear that, in the short-term at least, little urea will flow from Chinese ports. This provided further support to the broader urea market during mid- to late October, though price increases were generally at a lower rate than earlier in October. Liquidity continued to be relatively thin, but urea prices notably rose in Egypt (to \$845/t f.o.b.) and Oman (to \$760/t f.o.b.). Ammonium nitrates also saw large price increases as producers continued to take advantage of high demand from Europe to force American markets to pay up.

Recent market drivers include: Chinese export restrictions – with at least three export cargoes facing difficulties, the market is unable to count on exports from China to help meet the supply deficit; demand destruction – no region is proving immune to the imbalance between fertilizer and grain prices; and European natural gas prices – prices in Europe remain at elevated levels, though fertilizer prices have caught up enough to incentivise output from EU factories in the short-term.

The outlook for nitrogen is firm. High gas prices will squeeze marginal nitrogen supply in Europe and Ukraine, cutting production of urea and nitrates. This is lifting Europe's call on African urea supplies. India is also in a difficult position

– domestic production has lagged 2020 levels all year despite the start-up of Ramagundam. On paper, India needed 5 million tonnes of urea in the fourth quarter of this year, but only 740,000 t was bought under the last RCF tender. And while we would expect Indian purchasing to be lower than our calculated requirement on paper, India will still need to make further tenders.

Following a ban on phosphate exports, China has also announced new customs export measures, effective from November 1st, requiring inspection certificates to ship fertilizer and related materials overseas. Traders are concerned that customs officials will not issue the certificates, turning this into a potential de facto ban on fertilizer exports. China shipped 2.9 million tonnes of urea from January to August this year, and the new measures could tighten a market already facing greatly reduced availability.

In the US, UAN prices are also higher due to the ongoing investigation into alleged dumping from Russian and Trinidadian producers. The US Department of Commerce is expected to announce its initial subsidy rates for foreign UAN production in November, which may reflect equivalent tariff rates unless revised.

Urea prices per unit N are now considerably higher than for ammonia or ammonium nitrate, which may lead to some substitution in the coming weeks.

Table 1: Price indications

Cash equivalent	mid-Oct	mid-Aug	mid-June	mid-April
<b>Ammonia (\$/t)</b>				
f.o.b. Black Sea	603-710	560-610	485-525	430-470
f.o.b. Caribbean	575-675	540-600	475-525	430-460
f.o.b. Arab Gulf	580-620	590-640	550-610	440-480
c.fr N.W. Europe	680-800	625-680	550-600	490-540
<b>Urea (\$/t)</b>				
f.o.b. bulk Black Sea	685-765	390-435	370-435	300-340
f.o.b. bulk Arab Gulf*	730-845	439-470	435-470	320-355
f.o.b. NOLA barge (metric tonnes)	719-840	400-440	445-495	365-405
f.o.b. bagged China	520-630	415-450	400-460	320-355
<b>DAP (\$/t)</b>				
f.o.b. bulk US Gulf	735-757	655-667	640-685	572-613
<b>UAN (€/tonne)</b>				
f.o.t. ex-tank Rouen, 30%N	n.m.	157	157	157

Notes: n.a. price not available at time of going to press. n.m. no market. \* high-end granular.

## END OF MONTH SPOT PRICES

### natural gas

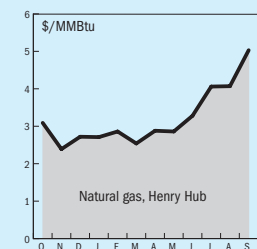

### ammonia

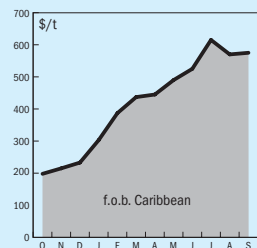

### urea

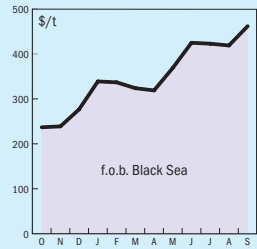

### diammonium phosphate

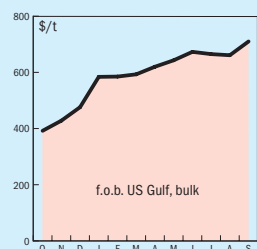

# Market Outlook

## Historical price trends \$/tonne

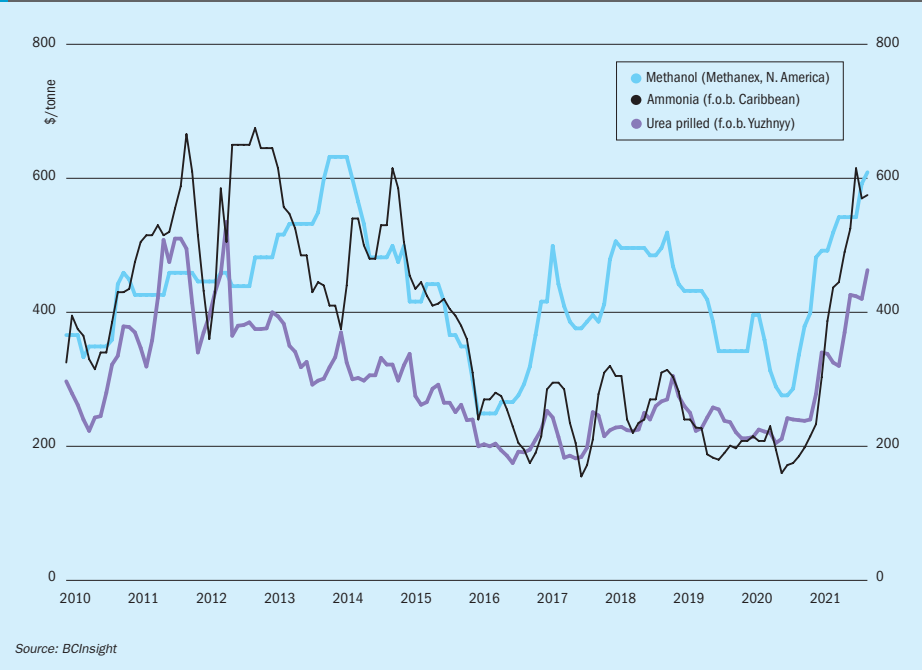

Source: BCInsight

## AMMONIA

- Soaring natural gas prices in Europe, up to five times higher than normal, have led to numerous economic shutdowns of ammonia capacity across the continent. This has coincided with shutdowns in the US due to hurricane season, reducing availability considerably and driving up prices in the western hemisphere.
- At the same time, however, demand had been relatively slack from India and China and the re-start of production at Ma'aden has meant availability east of Suez has been comfortable.
- The bull run in natural gas prices seems set to continue for now. LNG rates have been higher on strong demand in both Asia and Europe, and this has even dragged up Henry Hub prices in the US to values above \$6.00/MMBtu, their highest level (aside from the brief spike in February due to storm Uri) since 2014. With winter approaching and storage levels

low worldwide, there is no reason to expect major falls in gas price until 2022, with ammonia prices likely to stay high as a result.

## UREA

- Urea prices have reached unprecedented levels, rising over \$120/t in September and another \$200/t in October on the back of large scale Indian buying, reduced US output, rapidly rising gas and ammonia prices and consequent shutdowns in Europe, and China's announcement of increased customs restrictions on exports from November 1st, prompting a scramble to secure supply ahead of this. High global shipping rates are further contributing to increasing c.fr prices.
- Demand remains strong in Brazil, and it is reckoned India still needs to buy large quantities before the end of the year. Coupled with low or zero availability from China, it looks like that there is no sign of any let-up in high prices for the immediate future.

## METHANOL

- Negative margins for Chinese methanol to olefins producers are leading to shutdowns in production, with a knock-on effect on Chinese methanol consumption and hence production. Operating rates have dropped to very low levels.
- At the same time, high energy prices, as with ammonia, have been causing methanol prices to skyrocket. Natural gas prices have been the major reason, but this has been exacerbated in China by a surge in coal prices, rising 40% in October alone. With winter approaching in the northern hemisphere, at the moment there is no let-up foreseen in these high prices.
- The combination of lower demand in the largest methanol market coupled with high prices causing demand destruction makes for a very uncertain few months ahead. Chinese methanol futures have been very volatile. However, outside of China demand has been fairly strong, and for the time being the run of high prices looks like being sustained.



## EUROPE

## Gas prices force widespread plant shutdowns

Rapidly escalating natural gas prices forced plant closures across Europe during September. Worst affected was the UK, where a fire at a cross-Channel electricity cable and low output from wind energy has, combined with low domestic storage capacity led to a surge in demand for gas for power stations and wholesale gas prices reached a record 350 pence per therm (equivalent to \$46/MMBtu) in October. On September 15th, CF Industries announced that it was halting operations at both its Billingham and Ince fertilizer plants due to high gas prices. Although ammonia prices have also risen, they have not kept pace with gas price rises, and there is a limit to what farmers could be expected to pay. CF CEO Anthony Will said: “\$900 is the gas cost in a tonne of ammonia and the last trade in the ammonia market that was done was \$700 a tonne”. As these plants supply most of the UK’s carbon dioxide for food and drink manufacture, the government said it would provide “limited financial support” to keep the Billingham plant operational, and that plant re-started on September 21st. Meanwhile, BASF closed its Antwerp and Ludwigshafen plants in Belgium and Germany due to what the company called “extremely challenging” economics. Fertiherba ceased production at its Palos de la Frontera site in Spain, and Puertellano remained down for scheduled maintenance. Yara shut 40% of its European ammonia production in September, and OCI partially closed its Geleen plant in the Netherlands. Achema in Lithuania decided against restarting its ammonia plant following maintenance in August, and OPZ in Ukraine shut



BASF's ammonia plant at Ludwigshafen, Germany.

PHOTO: BASF

one ammonia line at Odessa, with Ostchem and DniproAzot likely to follow. Borealis in Austria also reduced production.

With winter fast approaching, Europe has been trying to find LNG shipments to stock up, but demand in Asia has made this difficult. There were also rumours that Russia’s Gazprom might be using supply pressure to try and gain approval for the start-up of its Nordstream 2 pipeline. In the meantime, Yara was bringing ammonia to Europe from Trinidad, the US and Australia. Yara said that it was impossible to say how long the high gas prices would last in Europe but that the company would be able to supply all of its customers with contracted volumes.

## NORWAY

## Large scale blue ammonia complex for the Barents Sea

Norwegian clean energy company Horisont Energi has signed a cooperation agreement with oil firms Equinor and Vår Energi for the development of Barents Blue, described as Europe’s first large-scale production facility for blue ammonia. The Barents Blue project is based on using natural gas to produce ammonia, then capturing 99% of the CO<sub>2</sub> in the process gas for permanent storage in the offshore Polaris reservoir below the seabed offshore Finnmark. The Polaris reservoir may have a storage capacity in excess of 100 million tonnes, equivalent to twice Norway’s annual greenhouse gas emissions. The facility is planned to consist of three ammonia process trains, which may be developed simultaneously or sequentially, including all required utilities for producing blue ammonia. Each train calls for a facility producing approximately 1.0 million t/a of pure ammonia per year.

Equinor and Vår Energi are the two largest offshore oil and gas producers in the

Barents Sea region, which are supposed to be among the natural gas suppliers to the Barents Blue ammonia plant. Vår Energi is the operator of the Goliat and Alke licenses in the Barents Sea. Goliat is mainly an oil field, but also holds natural gas currently being reinjected into the reservoir. Total recoverable resources in Alke and Goliat amount to about 25 bcm of gas.

Bjørgulf Haukelidsæter Eidesen, CEO of Horisont Energi said: “This agreement means that we are now moving forward in the Barents Blue project with two industrial partners with a strong local presence. They have a long-term perspective and bring extensive experience with large and complex technical projects. This is a major step forward for Barents Blue.”

Bjørn Thore Ribesen, VP Field Development and Projects in Vår Energi said: “Vår Energi has explored various alternatives for producing gas resources from these licenses. The potential for an ammonia plant has been included in our studies over the past year. This agreement strengthens our ambitions for a gas evacuation solution in the region.

Horisont has also been making other agreements, including a license agreement with Honeywell for the latter’s UniSim Design

process modelling software to verify and optimize the design of its carbon-free ammonia plants, and a memorandum of understanding with Kooles Terminals to collaborate on the development of an ammonia terminal at the Port of Rotterdam. UK engineering and consultancy firm Wood has entered into a framework agreement with Horisont over the development of the project, and earlier, in June, commissioned Technip and Saipem for two separate feasibility studies for the project. The company says that it is also in discussions with a number of infrastructure investors regarding project financing.

## Wärtsilä and Eidesvik Offshore to convert ship to run on ammonia

The technology group Wärtsilä and Norwegian ship owner Eidesvik Offshore ASA have signed a cooperation agreement aimed at converting an offshore supply vessel (OSV) to operate with an ammonia-fuelled combustion engine with associated fuel supply and safety system. This project will be the first of its kind in the world, say the partners, and has a provisional completion target by the end of 2023.

The OSV considered for a retrofit currently has Wärtsilä dual-fuel engines operat-

ing primarily with LNG fuel. The conversion will allow the vessel to operate with a 70% ammonia blend. Wärtsilä has already successfully laboratory tested an engine with such a blend. The ultimate goal is to achieve operation with 100% ammonia and with a minimum ignition fuel requirement. As a fuel, ammonia has the potential to drastically reduce emissions of CO<sub>2</sub>. Both Wärtsilä and Eidesvik have stated their commitment to supporting the industry’s efforts to decarbonise its operations.

“Using ammonia as a fuel is seen as a key future contributor to shipping’s energy transition, and we’re excited to be the first offshore ship owner taking this step. This project is yet another confirmation of our strong reputation as a pioneer in implementing new environmental technologies in both new builds and the existing fleet,” said Eidesvik CEO & President, Jan Fredrik Meling.

“Collaborating with Eidesvik on this ground-breaking project is an exciting and important step towards carbon-free shipping. Naturally we are also working with classification societies on measures to ensure safe and environmentally sustainable use. We are already well advanced in the development of ammonia as a viable marine fuel, and are actively working on other future carbon-free fuels as well. Our strong in-house competences are very much being utilised to support our commitment to decarbonising shipping,” said Hans Petter Nesse, Managing Director of Wärtsilä Norway.

Wärtsilä and Eidesvik are also partners in the EU-funded ShipFC project to equip a platform supply vessel, the ‘Viking Energy’ with a 2MW fuel cell running on green ammonia. The installation is scheduled to take place in late 2023. This ammonia conversion project also ties in with one of the ongoing work streams of the Wärtsilä-led Zero Emissions Energy Distribution at Sea (ZEEDS) project, aimed at developing ammonia-powered new builds and converting suitable existing vessels.

## UNITED STATES

## Air Products plans \$4.5 billion clean energy complex

Air Products has announced that it is planning to build a huge, \$4.5 billion clean energy complex at Ascension Parish in Louisiana. The company will build, own and operate the project, which will be based on the production of 750 million scf/d of blue hydrogen, using natural gas, with the carbon dioxide

in the production process captured for permanent sequestration. A portion of the blue hydrogen will be compressed and supplied to customers by Air Products’ extensive Gulf Coast hydrogen pipeline network, stretching more than 700-miles from Galveston Bay in Texas to New Orleans, and already including blue hydrogen from Air Products’ Port Arthur, Texas facility.

The balance of the hydrogen from the new facility will be used to make ammonia that will be transported around the world and converted back to hydrogen for transportation and other markets. The project has a target on-stream date of 2026.

Louisiana governor Edwards said: “This is a major industrial investment that will create quality manufacturing jobs while limiting environmental impacts, a goal envisioned by my Climate Initiatives Task Force. Carbon capture and sequestration are important to Louisiana’s efforts to reduce carbon dioxide emissions while maintaining jobs and growing our manufacturing base. This project is a clear demonstration of our ability to grow the Louisiana economy while lowering the carbon footprint of industry.”

Haldor Topsoe will provide its Blue Ammonia technology for the complex. Roeland Baan, CEO of Haldor Topsoe said: “We are happy to support Air Products in their rapid expansion of renewable offerings through our partnership framework. We believe that this significant project will showcase our unique ammonia technology in a true world-scale setting.”

## Feasibility study on green ammonia plant for Iowa

Maire Tecnimont says that its subsidiaries NextChem, MET Development and Stamicarbon have reached an agreement with US-based Greenfield Nitrogen LLC, to develop the first dedicated green ammonia plant in the US Mid-west. As part of the agreement, NextChem will begin a feasibility study for the 240 t/d green ammonia plant, using renewable energy to generate hydrogen for the facility. MET Development will assist Greenfield Nitrogen in the development of the project. The plant will be designed using the best available technologies for green hydrogen production together with ammonia technology that will be provided by Stamicarbon, which earlier this year launched its new STAMI Green Ammonia technology.

The project is the first of a series of green ammonia facilities that Greenfield

Nitrogen is interested to strategically develop in the US Corn Belt. The plant and storage facility, which will be located near Garner, Iowa, will be powered by local renewable sources and will supply the ammonia to the local market, which traditionally is a large ammonia-consuming market. The green ammonia plant will strengthen the development of the low carbon industry in the region and is expected to save over 166,000 t/a of CO<sub>2</sub> emissions. The production of around 83,000 t/a of ammonia will reduce the region’s dependency on imports from abroad.

Pierroberto Folgiero, Chief Executive Officer of Maire Tecnimont Group commented: “We are very pleased that Greenfield Nitrogen has chosen Maire Tecnimont as their partner of choice for this exciting project. The combination of co-developer, technology provider and EPC contractor makes Maire Tecnimont a unique player in the green ammonia market, an area that will be vital to industrialize the on-going energy transition through green hydrogen.”

## New branding for Sabin Metal Corp.

Sabin Metal Corporation has launched a new brand identity, including a new logo, brand elements, typography and a new website. The website aims to provide a trusted resource for best practices and detailed information on precious metal recycling services to clients and partners. The company has also recently expanded its platinum group metal refinery to produce more platinum and palladium per month, and completed construction, certification, and launch of a third kiln for catalyst processing.

## AUSTRALIA

## Feasibility study on million tonne ‘blue ammonia’ plant in Australia

Japanese trading house Mitsui says that it is conducting a feasibility study on plans to invest more than \$900 million to build a 1.0 million t/a ‘blue’ ammonia plant in Western Australia. Gas from the Waitsia field, in which Mitsui holds a 50% stake, would be used to produce ammonia, with the CO<sub>2</sub> generated during production being compressed and then fed back into depleted reservoirs within the field. The ammonia would be exported to Japan and supplied to domestic electric power companies. The target date for completion of the project, assuming positive results from the feasibility study, is 2028. Mitsui

## CONTENTS

What’s in issue 374

## COVER FEATURE 1

The slowing MTO boom

## COVER FEATURE 2

Barriers to trade

## COVER FEATURE 3

Green technologies

## COVER FEATURE 4

Wastewater treatment

NITROGEN+SYNGAS  
ISSUE 374  
NOVEMBER-DECEMBER 2022

BCInsight

Southbank House, Black Prince Road  
London SE1 7SJ, England

Tel: +44 (0)20 7793 2567

Fax: +44 (0)20 7793 2577

Web: www.bcinsight.com  
www.bcinsightsearch.com



is collaborating with Australian fertilizer producer Wesfarmers on the production side, and the Japan Oil, Gas and Metals National Corporation (JOGMEC) on CO<sub>2</sub> storage. Memoranda of understanding have been signed with both companies.

**Incitec Pivot looking to green ammonia**

Incitec Pivot, in conjunction with Fortescue Future Industries says that it is planning to build an electrolysis plant at its Gibson Island ammonia plant near Brisbane to produce a clean hydrogen feed for the facility. According to the companies, up to 50,000 t/a of green ammonia could be produced. Incitec Pivot managing director Jeanne Johns said the project could sustain highly skilled manufacturing jobs at Gibson Island and allow the company to leverage its existing capabilities and assets to create a “thriving renewable hydrogen ecosystem in Australia in the near term.”

**Tasmanian green ammonia project**

Japanese power producer and wholesaler J-Power and Australian utility and gas firm Origin Energy have signed a cooperation agreement to develop a green ammonia plant on Tasmania state, aiming to ensure stable supplies of the fuel to support Japan’s decarbonisation efforts. The partners are looking at a 420,000 t/a ammonia plant at Bell Bay in northern Tasmania, looking to export it to co-fuel coal-fired power plants in Japan. Japanese shipping firm Mitsui OSK Lines also agreed with Origin Energy in August to look into developing a supply chain to support exports of green ammonia from Australia to Japan.

**Ammonia from biomass gasification**

Port Anthony Renewables and Singapore’s global gasification technology integrator CAC-H2 have formed a joint venture to build and commission a waste woody biomass gasification system to produce green hydrogen and ammonia for both domestic use and export internationally. The initial pilot plant will produce 3 t/d of hydrogen for domestic distribution, but the joint venture also plans to build a larger scale green ammonia production plant for export to Asia with a capacity of at least 30,000 t/a.

Benjamin Anthony, Managing Director of Port Anthony Renewables commented: “This joint venture with CAC-H2 brings proven established technology replicated from its previous global projects. Our goal for the Port Anthony Renewables Hub is to include every aspect of green hydrogen pro-

duction, storage and distribution, and a bio-mass project such as this represents a low CAPEX, and a shorter approvals pathway.

**Woodside Petroleum looking to hydrogen and ammonia hub at Kwinana**

Oil and gas company Woodside has announced plans to build a hydrogen and ammonia production hub on government land south of Perth. The A\$1 billion project, ‘H2Perth’ is ultimately envisaged to produce 1,500 t/d of hydrogen for export in the form of ammonia and/or liquid hydrogen. The first phase of the project would be aimed at producing mostly ‘blue’ hydrogen using natural gas supplied by Woodside, with around one third of the output as ‘green’ hydrogen produced from renewable energy through the South West Interconnected System, which includes rooftop solar power.

Hydrogen and ammonia from H2Perth would be produced using both electrolysis technologies and natural gas reforming, with 100% of carbon emissions abated or offset. The electrolysis component of H2Perth’s production will have an initial capacity of 250 MW, with potential to scale to more than 3 gigawatts (GW) alongside both customer demand and renewable energy growth. The initial phase of the steam methane reformer will consume 40 terajoules per day of natural gas. Initially, H2Perth will target 300 t/d of hydrogen production, or 20% of expected total capacity, which can be converted into 600,000 t/a of ammonia or 110,000 t/a of liquid hydrogen.

Woodside plans to start community engagement on the project soon and, subject to necessary commercial and regulatory approvals and a final investment decision, construction is aiming to start in 2024.

Woodside chief executive Meg O’Neill said: “H2Perth will... facilitate substantial growth of renewables in Western Australia by providing to the grid a flexible and stabilising load that benefits uptake of intermittent renewable electricity by households and local industry. Emissions from the first phase electrolysis component will depend on the energy mix at the time of purchase from the grid. We will look at enabling more renewables to enter the grid as future phases require more power.”

**OMAN**

**Green ammonia for Oman?**

Another feasibility study on green ammonia production has been announced, this time by a consortium comprising Omani state oil

and gas company OQ, Japan’s Marubeni, Linde, and UAE-based Dutco. The project, aiming to produce up to 330,000 t/a of green ammonia, would be sited in the Salalah Free Zone in the south of Oman. The partners are planning to build a 400 MW electrolyser for the production of green hydrogen that will use solar and wind power from existing and new parks with a total capacity of 1 GW. The project, SalalahH2, aims to make Salalah a hub for the production and export of green hydrogen and ammonia, benefitting from the potential for solar and wind capacity in the region and the infrastructure at the Port of Salalah. The companies in the consortium will study various off-take options, including fertilizer plants in Europe, the global shipping industry and coal-fired power plants in Asia.

**JAPAN**

**Yara to supply ‘clean ammonia’ to Kyushu**

Yara International has signed a memorandum of understanding with Japan’s Kyushu Electric Power Co., Inc (Kyushu) to collaborate on establishing ‘clean ammonia’ supply chains in Japan to reduce CO<sub>2</sub> emission at Kyushu’s coal-based thermal power plant in the Kyushu region, as well as to jointly develop a receiving and distribution system for clean ammonia for use in a wide range of fields around the region. Japan is targeting 3 million t/a of ammonia import demand for fuel by 2030 and 30 million t/a by 2050 as part of its measures to cut CO<sub>2</sub> emissions and reach carbon neutrality by 2050.

**Ammonia co-firing tests begin at power plant**

Japan’s biggest power generator JERA and IHI Corp have begun to use small volumes of ammonia along with coal at JERA’s Hekinan power station in central Japan as part of an effort to reduce the facility’s emissions of carbon dioxide. The co-firing project is a part of a plan to use more ammonia alongside coal at large-scale commercial coal-fired plants as part of a shift to cleaner fuels. The demonstration project will run until March 2025, with a target of eventually achieving a co-firing rate of 20% at the 1 GW No. 4 plant. The first phase will burn 200 tonnes of ammonia by December 2021 in the No. 5 plant, to test materials and combustion times in a co-firing burner before the larger volume – around 40-50,000 t/a – is used for co-



**WE KNOW OUR WAY AROUND ENGINEERING**

Think about thousands of highly skilled professionals with distinctive competences and technological know-how operating in the hydrocarbon processing sector.

Petrochemicals, oil&gas refining and fertilizers are our core industries, while we aim at accelerating the world energy transition through low carbon technologies and green chemistry.

This is **Maire Tecnimont Group**: a plant engineering leader focused on the chemical processing of conventional and renewable energy resources into advanced products embedded in everyday life.

**45** COUNTRIES

**~1500** TOTAL DELIVERED PROJECTS

**50** COMPANIES

[www.mairetecnimont.com](http://www.mairetecnimont.com)



**CONTENTS**

What’s in issue 374

**COVER FEATURE 1**

The slowing MTO boom

**COVER FEATURE 2**

Barriers to trade

**COVER FEATURE 3**

Green technologies

**COVER FEATURE 4**

Wastewater treatment

NITROGEN+SYNGAS  
**ISSUE 374**  
NOVEMBER-DECEMBER 2022

**BCInsight**

Southbank House, Black Prince Road  
London SE1 7SJ, England  
Tel: +44 (0)20 7793 2567  
Fax: +44 (0)20 7793 2577  
Web: [www.bcinsight.com](http://www.bcinsight.com)  
[www.bcinsightsearch.com](http://www.bcinsightsearch.com)



firing in the No. 4 unit. JERA is a joint venture between Tokyo Electric Power and Chubu Electric Power. IHI, which makes burners among other industrial machinery, has said separately that it has begun developing a large ammonia receiving terminal to help build an ammonia supply chain.

**EGYPT**

**Green hydrogen feed proposed for EBIC**

Fertiglobe, an ammonia and urea producer jointly owned by OCI and the Abu Dhabi National Oil Company (ADNOC), has signed a partnership agreement with Norwegian energy company Scatec and the Sovereign Wealth Fund of Egypt (TSFE) for a project to convert green hydrogen into green ammonia by 2024, using new solar and wind energy capacity. The 90,000 t/a plant would be sited at Ain Sokhna, near Suez. Scatec will build, operate and majority own the renewable hydrogen facility, which would then supply hydrogen feedstock to Fertiglobe's subsidiary EBIC, which already operates a 750,000 t/a ammonia plant at the site. Scatec would also enter into a long-term green ammonia purchase agreement with EBIC.

According to Scatec, engineering and development work, including the structuring of commercial agreements for the new facility, will begin shortly. A final investment decision will be made in 2022 and the hydrogen facility would be commissioned in 2024, subject to regulatory approvals from the Egyptian authorities. In addition, Fertiglobe, Scatec and TSFE will need to seek support from multilateral development institutions and solicit the services of hydrogen technology providers.

Ahmed El-Hoshy, CEO of OCI and Fertiglobe, said: "We are pleased to partner with Scatec, a leader in the global renewables market and Egypt's largest renewable power developer, to deploy cutting-edge technology at world scale to start ramping up our green ammonia production profile. This project adds to our existing and rapidly developing low-carbon portfolio of ammonia across our global platform, and Fertiglobe in particular is increasingly becoming the ideal springboard to capture the huge growth opportunities offered by the hydrogen economy."

Separately, ADNOC and OCI have decided to offer 13.8% of shares in Fertiglobe in an initial public offering (IPO). Currently Fertiglobe is 58:42 joint venture between the two companies. ADNOC is expected to indirectly own at least 36.2% of Fertiglobe's shares

post-IPO, while OCI will continue to own the majority of the company.

Fertiglobe is also working with ADNOC and UAE sovereign wealth fund ADQ to develop a 1 million t/a blue ammonia facility at Ruwais in the UAE emirate of Abu Dhabi, with start-up projected for 2025.

**SAUDI ARABIA**

**Work on NEOM ammonia plant to begin early next year**

ACWA Power says that it expects construction work on its \$6.5 billion NEOM green hydrogen and ammonia project to begin in the first half of 2022. Financial closure on the plant, a joint venture with Air Products, is also expected early next year, with ammonia production beginning in 1Q 2026. It will be sited at the futuristic NEOM city project on Saudi Arabia's Red Sea coast. The plant will need around 4.3 GW of clean energy to power it and ACWA plans to use solar power in the day and wind energy at night to eliminate the need for batteries and expensive storage solutions. It will produce 650 t/d of hydrogen and 1.2 million t/a of green ammonia, reducing carbon dioxide emissions by the equivalent of 3 million t/a.

**MALAYSIA**

**Samsung to lead blue and green ammonia developments**

A consortium led by South Korea's Samsung Engineering is planning to develop a green hydrogen and ammonia project at Bintulu, Sarawak province, dubbed H2biscus. Other partners in the H2biscus consortium include South Korean companies Posco International and Lotte Chemical and Malaysian state owned SEDC Energy – a subsidiary of the Sarawak State Economic Development Corp (SEDC). The project is expected to produce 7,000 t/a of green hydrogen for Sarawak's local use, in addition to 600,000 t/a of blue ammonia, 630,000 t/a of green ammonia and 460,000 t/a of green methanol. A pre-feasibility study has reportedly been completed and the main feasibility study is expected to start this year.

Samsung Engineering, Posco and Lotte Chemical will be taking an active role in developing the entire cycle of the project, which include direct investment, construction, transportation and utilisation. Contracts for front-end engineering and design and engineering, procurement and construction are expected to be awarded next year.

Samsung is also currently executing the \$900 million Sarawak Petrochemical methanol plant project in Bintulu. The state-owned methanol plant, which is earlier targeted for completion this year, is expected to produce 5,000 tonnes per day of methanol and methanol derivatives.

Sungan Choi, president of Samsung Engineering, said: "The company is channelling its efforts to be a 'beyond EPC green solution provider', providing green infrastructure and energy optimisation services through process analysis. By developing new hydrogen-related technologies and carbon capture, usage and storage technology, the company is aiming to transform the energy industry. [This project] will serve as an exemplary project of international standing for renewable energy trading and hydrogen transportation between South Korea and Malaysia, establishing hydrogen-related standards for the two countries."

**RUSSIA**

**New nitric acid and AN complex for KuibyshevAzot**

KuibyshevAzot has contracted Casale to build a new 1,575 t/d nitric acid plant and 2,000 t/d ammonium nitrate solutions plant at its site at Togliatti. Casale had previously completed front-end engineering design work prior to the Covid-19 pandemic. The complex, which is due for completion in 4Q 2024, will incorporate Casale's NA2000™ dual pressure process for nitric acid and AN2000™ technology for AN solutions production to ensure low consumption and reduced emissions. Casale will be responsible for turnkey execution and its Czech subsidiary – Casale Project – in the construction phase.

Federico Zardi, CEO of Casale commented: "We are particularly proud of this new win for our company which, in addition to strengthening the cooperation between Casale and KuibyshevAzot, comes in the wake of the successful completion of another nitric acid plant in Uzbekistan of very similar capacity, thus confirming both our commitment in pursuing large EPC projects as well as the importance of the Russian and CIS markets for the development of our business. In addition, we strongly believe that the consistent use of highly qualified local resources in different phases of the construction – as planned for this project – besides bringing clear benefits in terms of speed and efficiency of ex-

ecution, also generates positive effects on the local economy and employment, creating the conditions for further collaborations as well ensuring the basis for a prosperous future for all stakeholders."

**KBR wins services contract with EuroChem**

KBR has been awarded a three-year service contract by EuroChem for its ammonia plant in Kingisepp, Russia. Using a cloud-based platform, KBR's INSITE process package will provide remote monitoring and advisory service to help improve plant operations. Under the terms of the contract, KBR will analyse EuroChem's ammonia plant operations and use the domain knowledge of KBR experts to identify opportunities for achieving sustainable improvements in production, reliability, environmental impact, and energy efficiency.

"KBR has a longstanding and collaborative relationship with EuroChem and we are pleased to offer our KBR INSITE advisory services to ensure optimal plant operations for EuroChem," said Jay Ibrahim, KBR President, Sustainable Technology Solutions. "We look forward to equipping this facility with best-in-class sustainable digital solutions and keep safety, environment, and energy-efficiency at the core of the strategy."

**Stamicarbon to build second granulation plant for Acron**

Maire Technimont subsidiary Stamicarbon will supply a 2,000 t/d urea granulation plant using its own technology and proprietary equipment for JSC Acron's Veliky Novgorod site. It is the second award for Stamicarbon by Acron after a previous

granulation plant with the same capacity was completed in 2020. The new plant will be based on the same design as the first, and will use the company's proprietary film spraying nozzles, which help to build up the granules layer by layer, resulting in what Stamicarbon claims is a better quality end product. It also offers savings in lower operating expenditure compared to other fluidised bed granulation processes due to reduced formaldehyde content in the final product and low dust formation. The company says that this results in an average operation time of three months, without interruption for cleaning.

"Since the start of its operation in the summer 2020, the first granulation unit has demonstrated excellent performance, both in terms of process reliability and equipment," said Sergey Abramov, licensing manager at Stamicarbon. "Acron appreciated our technology and as a result chose Stamicarbon for the second unit of the same design and capacity."

**PAKISTAN**

**Government approves additional gas for fertilizer production**

Pakistan's cabinet Economic Coordination Committee has approved additional natural gas supplies to the Pak-Arab Fertilizer Plant and Fauji Fertilizer Bin Qasim Ltd in a bid to help stabilise urea prices. Reviewing demand for urea during the post-monsoon Rabi season from October 2021, the committee approved 58 million scf/d of gas for Pak-Arab and 63 million scf/d for Fauji Fertilizer to ensure that projected demand for urea fertilizer was met through domestic production.

**INDIA**

**Matix settles debt**

Matix Fertilisers & Chemicals Ltd has made a one time settlement of \$41.0 million to settle completely its outstanding \$600 million debt with creditors, including IDBI Bank Limited, State Bank of India, Canara Bank, Axis Bank Limited, Central Bank of India, Bank of Baroda, Bank of India, Union Bank of India, Punjab National Bank, Exim Bank and the India Infrastructure Finance Company (UK). The deal was concluded in August after three years of negotiations between lenders and the company.

Matix has accrued the debts in its 2,200 t/d ammonia and 3,850 t/d urea plant and associated power unit based at Panagarh in West Bengal.

**SOUTH KOREA**

**KBR to license nitric acid plant**

KBR has been awarded a dual-pressure nitric acid technology contract by Hanwha Corp. for the latter's new plant at Yeosu. Under the terms of the contract, KBR will provide the technology license, basic engineering design, and technical support to Hanwha for a 1,200 t/d dual pressure nitric acid plant.

"KBR is proud to be selected by Hanwha to deliver our leading dual-pressure nitric acid technology that offers tangible CAPEX and OPEX benefits including reduced net energy consumption through efficient energy recovery," said Doug Kelly, KBR President, Technology. "This contract highlights KBR's continued commitment to bringing energy-efficient sustainable technologies to the industry."

**CONTENTS**

What's in issue 374

**COVER FEATURE 1**

The slowing MTO boom

**COVER FEATURE 2**

Barriers to trade

**COVER FEATURE 3**

Green technologies

**COVER FEATURE 4**

Wastewater treatment

NITROGEN+SYNGAS  
**ISSUE 374**  
NOVEMBER-DECEMBER 2022

**BCInsight**

Southbank House, Black Prince Road  
London SE1 7SJ, England  
Tel: +44 (0)20 7793 2567  
Fax: +44 (0)20 7793 2577  
Web: www.bcinsight.com  
www.bcinsightsearch.com



**Watch free fertilizer market presentations**

Argus deliver concise and insightful webinars analysing the nitrogen, phosphate, potash, sulphur and sulphuric acid markets. The webinars are offered on-demand and live – and are completely free to watch.

Watch the free webinars here:  
[www.argusmedia.com/webinars](http://www.argusmedia.com/webinars)



DENMARK

## Demonstration plant to produce methanol from biogas

Topsoe has begun operations at a demonstration plant for the production of methanol from biogas. The aim is to validate the company's electrified technology for cost-competitive production of sustainable methanol from biogas as well as other products. The project is supported by the EUDP Energy Technology Development and Demonstration Program and is developed together with Aarhus University, Sintex A/S, Blue World Technology, Technical University of Denmark, Energinet A/S, Aalborg University, and PlanEnergi. The demonstration plant is located at Aarhus University's research facility in Foulum, and will have an annual capacity of 7.9 t/a of CO<sub>2</sub>-neutral methanol from biogas and green power and is scheduled to be fully operational by the beginning of 2022. It uses Topsoe's eSMR™ technology, which is CO<sub>2</sub>-neutral when based on biogas as feedstock and green electricity for heating. It also uses half the CO<sub>2</sub> that makes up about 40% of biogas and typically is costly to separate and vent in production of grid quality biogas.

"Fighting climate change demands clean fuels for all sectors. With this initiative, we will demonstrate that we are able to transform classical production process into a fully carbon-neutral scheme. Specifically, we will demonstrate that sustainable Methanol can be produced from biogas at a very competitive cost compared to other green methanol produced from non-fossil fuels," said Kim Grøn Knudsen, Chief Strategy and Innovation Officer at Haldror Topsoe.

In separate news, Aarhus University will also host the world's first interdisciplinary research centre to convert CO<sub>2</sub> in the atmosphere into sustainable raw materials, with the Novo Nordisk Foundation providing €84.7 million of funding to establish the centre.



Topsoe's new biogas to methanol demonstrator plant.

UNITED STATES

## Arbor to use Topsoe methanol to gasoline technology

Arbor Renewable Gas, LLC will use Topsoe's TIGASTM technology to produce renewable gasoline at a new facility in the Gulf Coast region. The facility is expected to be operational by 2024 to produce 1,000 bbl/d of renewable gasoline with a significantly negative carbon intensity score under California's Low Carbon Fuel Standard. Topsoe will supply the methanol synthesis technologies and the backend gasoline synthesis unit, based on its modular MeOH-To-Go™ design. Feedstock will be woody biomass.

"We are proud that Arbor Gas has chosen our technology for this truly innovative project to decarbonise transportation fuels. By contributing with our world-leading technology, a uniquely integrated solution, incorporating the full value chain from syngas to methanol into gasoline, we support Arbor Gas in their efforts to accelerate the US transition to low carbon fuels, shaping a more diverse and sustainable transportation system," said Fei Chen, Senior Vice President at Topsoe.

## KP Engineering and OMNI Conversion Technologies to cooperate on hydro-gasoline from waste

KP Engineering, LP has entered into a collaboration agreement with OMNI Conversion Technologies Inc. OMNI is a Canadian company focused on producing clean green energy by converting energetic waste into OmniSyngas™ and OmniRock™, with full diversion from landfill. The collaboration will enable the companies to supply equipment and technology to produce hydrogen from waste with a negative carbon footprint at less than half the cost of electrolysis. KPE and OMNI will co-market OMNI's patented technology and collaborate to provide an integrated modular solution for converting a wide variety of minimally prepared wastes to hydrogen, while capturing CO<sub>2</sub> for subsequent use or sequestration. Biomass-fed projects will fall outside of the scope of the agreement.

William E. Preston, president and chief operating officer, KP Engineering, said, "The partnership between KPE as an industry-leading EPC with a ground-

breaking technology provider such as OMNI embodies the type of collaboration that will bring green hydrogen to fruition. This agreement solidifies an already highly efficient working relationship between KPE and OMNI, and will bring to market a cost-effective, zero- and even negative-carbon emission option for producing green hydrogen."

## New members for Methanol Institute

The Methanol Institute (MI) says that it is pleased to welcome WasteFuel and Greenfield Global as the association's two newest member companies. WasteFuel transforms municipal and agricultural waste into sustainable low-carbon fuels, renewable natural gas, and green methanol using scalable technologies, and has attracted investments from the world's largest shipping company (and fellow MI member) A.P. Moller-Maersk. WasteFuel is also developing additional projects including a biorefinery in Manila, Philippines, to produce low-carbon aviation fuels.

Greenfield Global provides raw materials, ingredients and additives. Its Quebec

facility is an example of low-carbon renewable fuel production and circular innovation. Greenfield partnered with the Port of Montreal to develop and commercialise green hydrogen and methanol solutions for the maritime industry. It is also working in collaboration with Hydro Quebec to develop an e-methanol project adjacent to its ethanol plant in Varennes, Quebec. The initial phase of this project will include a 60MW electrolysis unit for the production of hydrogen. Hydrogen output from the electrolyzer, along with biogenic CO<sub>2</sub> from the ethanol plant will be fed to a methanol synthesis unit to produce approximately 48,000 t/a of low-carbon methanol.

MI CEO Greg Dolan welcomed the companies to MI, noting that "We are pleased that WasteFuel, a company on the cutting edge of innovation, has decided to join the growing ranks of MI members looking to provide the clean fuels of today and tomorrow. Greenfield Global's expertise in innovation and low-carbon fuel production spans decades. MI is delighted to welcome Greenfield as our newest member and have them join our ranks of companies committed to providing low-carbon fuels."

## GTL proposal for North Dakota

Canadian company Cerilon Inc has announced plans for the development of a \$2.8 billion gas to liquids (GTL) plant at Trenton in the west of North Dakota. State officials indicated that they would be providing \$3 million in initial investment via the Department of Commerce, with more state funding for the project likely down the line. The project would aim to convert natural gas that would otherwise be flared from oil production in the Bakken field. North Dakota has long struggled to find uses for the large amounts of associated natural gas produced from its oil fields; the state lacks the pipeline infrastructure to capture, utilise and export all of its natural gas output, meaning that many companies end up flaring the gas on site, amounting to 8% of all gas produced. Furthermore, as the wells in the Bakken formation continue to mature, they will produce higher and higher volumes of natural gas, output that could eventually put a cap on North Dakota's oil production because of regulatory requirements on flaring. Cerilon's proposed GTL plant would produce 24,000 bbl/d of diesel, jet fuel, naphtha and base oils, with construction aiming to begin in 2023, but other details about the project are scarce.

## Blue hydrogen to account for 85% of low-carbon hydrogen capacity in North America by 2030

Analyst company GlobalData says that it expects low-carbon hydrogen production in North America to nearly triple by 2030, reaching 1.4 million t/a. Most of this will be driven by blue hydrogen, which is expected to make up 85% of low-carbon hydrogen capacity by 2030.

Miles Weinstein, Energy Transition Analyst at GlobalData, commented: "Blue hydrogen production in North America is some of the cheapest in the world due to low natural gas prices and an abundance of suitable sites for geological carbon storage. Still, the cost of blue hydrogen production in the US is \$1.52/kg, compared to \$1/kg for grey hydrogen. While Canadian costs are comparable, Canada leads the US in blue hydrogen due mainly to existing natural gas extraction and carbon sequestration infrastructure, as well as funding for low carbon vehicles and fuels. In most other global regions, however, the capacity of green hydrogen plants far outpaces that of blue due to higher natural gas prices or, in some cases, cheap renewable electricity.

"While blue hydrogen is more expensive to produce than grey, US tax credits for carbon capture and storage effectively reduce the cost of blue hydrogen to \$1.26/kg, reaching \$1.11/kg by 2026. A similar tax credit is currently under consideration in Canada."

Producers of green and blue hydrogen in North America are targeting the transportation sector more than any other as a potential market. Meanwhile, automotive manufacturers, oil and gas companies, and others are beginning to build up a value chain for fuel cell electric vehicles (FCEVs) and hydrogen fuelling infrastructure. This is evidenced by recent industry partnerships, deals, and other activity in the hydrogen transportation sector, including a high-profile alliance between Chevron and Toyota to catalyse hydrogen transportation markets. Companies such as US-based Nikola Motor and ZeroAvia, have centred their business on medium- and heavy-duty hydrogen vehicles and hydrogen powered aircraft, respectively.

CHINA

## CO<sub>2</sub>-to-methanol plant

Chinese petrochemicals corporation Jiangsu Sailboat Petrochemicals Co. Ltd has signed an agreement with Icelandic

technology company Carbon Recycling International to design a chemical plant based on CRI's Emissions to Liquids (ETL) technology. The plant will recycle approximately 150,000 t/a of CO<sub>2</sub> and consume 20,000 t/a of hydrogen taken from other on-site processes to produce 100,000 t/a of methanol. The plant will be built in Lianyungang, Jiangsu province on the east coast of China, and will be integrated by Jiangsu Sailboat into their 15 km<sup>2</sup> Sheng-hong petrochemical industrial park.

Methanol is the main raw material used in Jiangsu Sailboat's existing 2.4 million t/a production of a wide product range of polymers and plastics. These include products used for making solar panels and plexiglass. The CRI ETL plant's direct use of 150,000 t/a of CO<sub>2</sub>, will equal the effect of taking 53,000 fossil fuelled cars off the roads. The plant will be owned and operated by Jiangsu Sailboat and is expected to begin its operation in 2023. The cost of the project is estimated at around \$35 million. It will be the second plant in China based on CRI's ETL technology. The first CRI project, the Shunli plant in Anyang, Henan province, is currently in the final stages of construction and expected to be in operation early next year.

"This agreement is exemplary of what the chemical industry can do to contribute to the fight against climate change. By utilising waste and by-product resources in an innovative way we can take the necessary steps to reduce emissions and replace traditional fossil fuels in the production of most of our consumer products," said Ingolfur Gudmundsson, CEO of CRI.

CHILE

## Construction begins on green methanol facility

Construction has begun on a new green methanol facility in Chile. The Haru Oni project will use wind energy from the southern Magallanes province power hydrogen production from electrolysis. CO<sub>2</sub> will be filtered from the air and combined with the green hydrogen to produce synthetic methanol for green fuel. The 100 t/a pilot plant is scheduled to start production in mid-2022. The capacity will then be expanded in two stages to around 43,500 t/a by 2024 and to around 435,000 t/a by 2026. The necessary environmental permits have now been obtained by the Chilean project company HIF (Highly Innovative Fuels). Siemens Energy has also already started preparatory

CONTENTS

What's in issue 374

COVER FEATURE 1

The slowing MTO boom

COVER FEATURE 2

Barriers to trade

COVER FEATURE 3

Green technologies

COVER FEATURE 4

Wastewater treatment

NITROGEN+SYNGAS  
**ISSUE 374**  
NOVEMBER-DECEMBER 2022

**BCInsight**

Southbank House, Black Prince Road  
London SE1 7SJ, England  
Tel: +44 (0)20 7793 2567  
Fax: +44 (0)20 7793 2577  
Web: www.bcinsight.com  
www.bcinsightsearch.com





A rendering of the proposed new methanol plant in Chile.

work for the next major commercial phase of the project. Other partners in the project include Porsche and HIF, Enel, ExxonMobil, Gasco and ENAP.

"I'm pleased that we're making progress on this international lighthouse project for the hydrogen economy together with strong international partners from business and politics," said Armin Schnettler, EVP for New Energy Business at Siemens Energy. "With Haru Oni, we're bringing our power-to-X technologies to the global market. We're jointly developing and realising the world's first integrated and commercial large-scale plant for producing synthetic, climate-neutral fuels. In southern Chile, we're implementing one of the energy industry's most exciting projects for the future and driving forward the decarbonisation of the mobility sector. It means we're making an important and rapidly effective contribution to reducing CO<sub>2</sub> emissions in the traffic and transport sector."

Chile has set itself ambitious targets as part of its National Green Hydrogen Strategy. It plans an electrolyser capacity of 5 gigawatts (GW) by 2025, rising to 25 GW by 2030. The aim is to produce the world's cheapest hydrogen and develop the country into a leading exporter of green hydrogen and its derivatives.

## UNITED KINGDOM

### Wind to hydrogen scheme proposed for Orkney

TotalEnergies and Repsol Sinopec are backing a proposal to transform the Flotta oil terminal in the Orkney islands off the northeast coast of Scotland into a green hydrogen production hub, which would be

powered by renewable energy from an offshore wind farm. The plans are supported by a consortium including TotalEnergies and Australia's Green Investment Group. The consortium is working on the hub project in partnership with Repsol Sinopec, which owns the Flotta terminal, and with hydrogen specialist Uniper. The firms working on the hydrogen plant proposal hope to be able to secure the funding and approvals required in time to be able to make a final investment decision in 2025 on whether to go ahead with the development.

### Matthey and CRI to collaborate on sustainable methanol

Carbon Recycling International (CRI) and Johnson Matthey (JM) have agreed a long term exclusive catalyst supply agreement for the use of JM's KATALCO™ methanol catalysts in CRI's Emissions-To-Liquids (ETL) process, which will be used in CRI CO<sub>2</sub> to methanol plants. Methanol manufactured using the ETL process and JM catalysts provides an effective route to produce sustainable methanol from CO<sub>2</sub>, using carbon dioxide recovered either from industrial processes or biomass, such as waste and residues, or atmospheric sources. JM's catalyst has been used in all CRI's plants to date, and their successful ten year cooperation will continue with this agreement.

"The need for proven, scaled and commercial solutions to produce sustainable chemicals and fuels has never been more urgent. Continuation of our long-standing cooperation with JM ensures that CRI can further strengthen its leadership in CO<sub>2</sub>-to-methanol technology and meet the needs of a growing number of clients adopting our

flexible Emissions-to-Liquids technology," said Ingólfur Guðmundsson, CEO of CRI.

"At Johnson Matthey our whole focus is about creating a world that is cleaner and healthier", said John Gordon, Managing Director, Johnson Matthey. "We believe we have a critical role in decarbonising the way chemicals are produced. We are excited to continue our long standing cooperation with CRI, since 2011, through the development of green methanol, building a cleaner future based on reduced emissions and more sustainable use of natural resources."

## ITALY

### NextChem and Johnson Matthey to commercially develop waste to methanol technology

MyRechemical, NextChem's subsidiary dedicated to waste to chemical technologies, and Johnson Matthey (JM), are to jointly cooperate to commercially develop waste to methanol technology worldwide. The technology converts non-recyclable municipal waste, which would otherwise be disposed in landfill or incinerated, into valuable syngas used to produce methanol. Through the chemical conversion of non-recyclable municipal and industrial waste, mainly plastic and dry waste the resulting hydrogen and carbon oxides can be used to produce more sustainable chemical products using JM's proven syngas-to-methanol technology. The methanol derived from this process can be used as an intermediate for low-carbon additives in the blending of gasoline and diesel, replacing the fossil-based component with one derived from recycling, as well as a raw material for the chemical, construction and plastic industries.

Pierroberto Folgiere, CEO of Maire Tecnimont Group and NextChem, commented: "The alliance with JM adds a new important piece to our business strategy. Circular methanol obtained from the technology on which we are partnering with JM can be used in better performing, low-carbon fuels for sustainable mobility, for example for the shipping sector, and as a more sustainable product for the chemical industry. There is a wide and promising market for such a product, aimed at driving the industry towards the use of more sustainable feedstocks, avoiding the consumption of natural resources. This technology, which is immediately applicable, provides a concrete answer to these needs".

## TRINIDAD & TOBAGO

### NiQuan to re-start this year?

NiQuan Energy, which manages the troubled gas to liquids facility at Pointe-a-Pierre, Trinidad, says that it is now looking to re-start production at the site by the end of 2021. The 2,500 bbl/d plant was conceived in 2005, and constructed next to the Petrotrin refinery at Pointe-a-Pierre by World GTL. However, although the plant was virtually completed in 2010, delays and cost overruns meant that it defaulted on its loan, which had been bought by Petrotrin from Credit Suisse, and the facility passed into government hands. But Petrotrin had no interest in operating it, and even planned to sell it as scrap at one point, before it was sold in 2016 to NiQuan, who aimed to get the facility up and running again. NiQuan have however faced their own delays, not least with Covid, but in March this year the company finally announced the plant's commissioning, until it was shut down in April following an explosion. NiQuan raised more finance in May while an investigation was carried out into the incident, but now hope to have the plant restarted by the New Year.

## MALAYSIA

### Petronas unit to provide support services for mega-methanol plant

Petronas Global Technical Solutions has entered into an agreement with Sarawak Petchem Sdn Bhd to provide advisory and technical support services for Sarawak's first mega methanol plant. The agreement covers advice on technical services, procurement and turnaround, as well as critical operations and maintenance support for the landmark Sarawak Methanol Project throughout its project execution and operation stages. Sarawak Petchem is currently constructing a 1.7 million t/a gas-based methanol plant at Bintulu, the first in the state.

with an annual capacity of 1.7 million metric tonnes per annum (mtpa). Its plant in Bintulu is currently under construction.

## INDIA

### Technip to build green hydrogen plant

Technip Energies has been awarded an engineering, procurement, construction and commissioning (EPC) contract by NTPC for its proton exchange membrane (PEM)-based hydrogen project at Vindhyachal,

Madhya Pradesh. The contract covers the delivery of a 5 MW hydrogen electrolysis unit which can be powered using renewable electricity in the future. NTPC is setting up this plant along with two other units; a CO<sub>2</sub> capture facility that takes carbon dioxide from flue gas stream of the coal fired power plant; and a downstream methanol unit that will use the captured CO<sub>2</sub> and the hydrogen from the electrolyser to convert it into green methanol.

### Pilot plant for high ash coal conversion to methanol

India has developed an indigenous technology to convert high ash Indian coal to methanol and established its first pilot plant in Hyderabad, according to the country's Department of Science and Technology. Coal-to-methanol plants in most countries are operated with low ash coals, and the high ash content of Indian coals can require higher heat to melt the ash. In order to overcome this challenge, Bharat Heavy Electricals Limited (BHEL) has developed a fluidised bed gasification technology to produce syngas and then convert the syngas to methanol with 99% purity. BHEL has integrated its existing coal to syngas pilot plant at Hyderabad with a downstream process for converting syngas into 0.25 t/d of methanol. This pilot has been initiated by NITI Aayog and funded by the Department of Science and Technology (DST) under its Clean Energy Research Initiative.

## GERMANY

### New methanol synthesis arrangement

Clariant, together with long-term partner in methanol synthesis Air Liquide have announced a new methanol synthesis set-up; *MegaZonE*. Based on Clariant's *MegaMax*™ catalyst series, the new arrangement uses several layers of catalysts with different activity levels to optimise heat management and overall catalyst performance in the methanol synthesis reactor. The properties of each catalyst layer are tailored to the specific conditions along the reaction pathway, which, the companies say, results in a significantly longer catalyst lifetime (by up to 2 years) and increased cumulative methanol production (up to 15%). Increased efficiency of the methanol synthesis loop means that it can be operated at milder conditions. Catalysts with moderate activity are

loaded in hotter zones of the converter to prevent hotspots, while activity-enhanced catalysts are placed further down the reaction pathway to intensify reaction rates in the lower portion of the converter. On the one hand, less thermal stress on catalysts will lead to longer catalyst lifetimes. On the other hand, high activity in the bottom part of the reactor increases reaction rates and reduces by-product formation by up to 10%.

*MegaZonE* technology is a drop-in solution and enables tailored refill options for optimisation of existing units. It also allows a more compact and resilient design for new plants. The arrangement has already been in use at two world-scale methanol plants in Asia this year, and has shown stable performance.

### INEOS green hydrogen project

INEOS, via its subsidiary INOVYN, has announced plans to build a large-scale, 100 MW electrolyser to produce green hydrogen at the company's Koln site in Germany. Hydrogen from the new unit would be used in the production of green ammonia, reducing carbon emissions at Koln by more than 120,000 t/a. The project will also look to develop E-Fuels through power-to-methanol applications at INEOS Köln on an industrial scale. Hydrogen will also be made available for other processes at the site, to chemical park operator Currenta – who will also provide important infrastructure to the project – and to other users in the region, to support the local sustainability agenda. The project has successfully passed the first selection phase of the EU IPCEI (Important Projects of Common European Interest) process.

INEOS has committed \$2.3 billion to green hydrogen development over the next few years, including a concept fuel-cell version of its Grenadier fuel cell car, using Hyundai technology, which will be built at the former Smart factory in Hambach, France, which was slated to produce electric cars before Smart parent Daimler sold it to Ineos.



INEOS hydrogen powered vehicles.

www.nitrogenandsyngas.com

## CONTENTS

What's in issue 374

## COVER FEATURE 1

The slowing MTO boom

## COVER FEATURE 2

Barriers to trade

## COVER FEATURE 3

Green technologies

## COVER FEATURE 4

Wastewater treatment

NITROGEN+SYNGAS  
ISSUE 374  
NOVEMBER-DECEMBER 2022

BCInsight

Southbank House, Black Prince Road  
London SE1 7SJ, England

Tel: +44 (0)20 7793 2567

Fax: +44 (0)20 7793 2577

Web: www.bcinsight.com  
www.bcinsightsearch.com

# People

Borealis has announced the appointment of **Rainer Höfling** as CEO of its International Fertilizer & Melamine business, as of 1st October 2018. This business unit comprises approximately 2,000 employees. The dedicated management team under the lead of Rainer Höfling will provide higher agility and increased customer focus for the business. Borealis runs fertilizer production sites in Austria, France, the Netherlands and Belgium and melamine production in Austria and Germany.



Rainer Höfling.

"Rainer Höfling is a dynamic, highly experienced and skilled leader and we are happy he will head our Fertilizer & Melamine business", says Alfred Stern, Borealis Chief Executive.

"I am excited to take up this challenge aimed at unleashing further opportunities in the fertilizer and melamine business," declared Rainer Höfling, CEO of the new Fertilizer & Melamine business. "I especially look forward to continue to create value for our customers and further increase their experience with us."

Rainer Höfling first joined Borealis in 2007 as director of its Business Unit Melamine. Since then, he has held the positions of vice president Polyolefins (PO) Moulding, vice president PO Advanced Packaging and Fibres and, most recently, senior vice president PO Sales. Before joining Borealis, Rainer Höfling held a number of senior management positions at Teufelberger GmbH, PCD Polymere and Neste Chemicals Germany. He was appointed as interim executive vice president Polyolefins and Innovation & Technology in April 2018.

**Ignacio Galán**, CEO of Iberdrola, a Spanish offshore wind company, has been chosen chairman of the Renewable Hydrogen Coalition, which supports renewable hydrogen as a means of meeting the EU's long-term decarbonisation targets. **Nils Aldag**, the creator and CEO of Sunfire, has been named vice-chairman for the next 18 months. The duo will contribute to the development of the EU's regulatory framework. Galán and Aldag will combine their knowledge in renewables and electrolyzers to manage the coalition's efforts to guarantee that, with the appropriate regulations, renewable hydrogen becomes a competitive alternative to conventional hydrogen this decade.

"The Renewable Hydrogen Coalition has a significant role ahead of it as Europe sets its policies to achieve carbon neutrality by 2050," said Iberdrola CEO Galán. "We have a once-in-a-lifetime chance to ensure that Europe leads the world in renewable hydrogen technology research and manufactur-

ing," he added. "The Fit for 55 package's goals for the use of renewable hydrogen in priority industries are highly beneficial in terms of increasing demand. These lofty goals must be matched by equally lofty implementation mechanisms, including financial assistance instruments to reduce the cost gap with fossil-fuel alternatives and give European buyers the confidence to convert to renewable hydrogen."

The European Commission's Fit for 55 package, which was unveiled in July, established explicit objectives for the fast and large-scale deployment of renewable hydrogen in difficult-to-electrify sectors. "This plan will enable these industries to achieve considerable carbon reductions while also boosting innovation, job creation, and industrial growth in Europe, solidifying the post-COVID-19 green rebound," according to Iberdrola.

**Dr. Siba Prasad Mohanty**, chairman and managing director of HIL (India) Ltd has been recommended by India's Public Enterprise Selection Board to become chairman and managing director of the Brahmaputra Valley Fertilizer Corporation Ltd (BVFL). Mohanty will also continue to head HIL (India) Ltd until a replacement is appointed. He has previously served as Director (Marketing) for HIL, and holds a masters in Business Management from Berhampur University, Odisha. He has more than 26 years of diverse experience primarily in fertilizer marketing. He has also worked at Rashtriya Chemical & Fertilizers Ltd (RCF), Mumbai, in different capacities from 1989 to 2015.

## Bringing Life To Your Fertilizer With Colours



ANTICAKING AGENT



DUST SUPPRESSOR

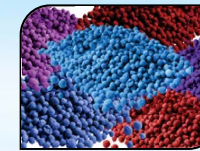

COLOURING AGENT



DIATOMACEOUS EARTH / REACTIVE SILICA

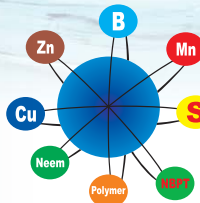

### Micronutrient Coating Technology

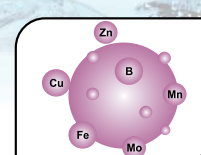

MICRONUTRIENT/TRACE ELEMENT FIXER



ANTIFOAM FOR PHOSPHORIC ACID



FROTH FLOTATION AGENT

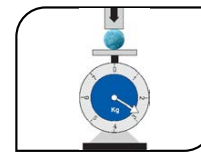

HARDENING AGENT



NEEM CAKE



NEEM OIL



### FREE FLOWING AND DUST FREE FERTILIZERS

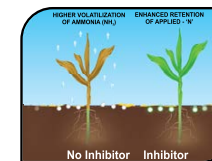

### Urease Inhibitor (NBPT) Nitrification Inhibitor (DMPP) Neem Oil

### BRIGHT Coloured Fertilizers

### GLOBAL PRODUCTION FACILITIES



• INDIA • UAE  
• BRAZIL • SPAIN



## NEELAM Aqua & Speciality Chem (P) Ltd.

701, North Avenue, Road No. 9A, V.K.I. Area, Sikar Road, Jaipur-302013 (INDIA)  
Ph. : +91-141-2333718, 2333418 • Fax : +91-141-2331102 • Mobile : +91-9829069545  
Email : mkmathur@neelamaqua.com, support@neelamaqua.com, www.neelamaqua.com

The following events may be subject to postponement or cancellation due to the global coronavirus pandemic. Please check the status of individual events with organisers.

## Calendar 2021/2022

### NOVEMBER

2-4

33rd AFA Technical Conference, SHARM EL SHEIKH, Egypt  
Contact: Mazen S. Ghoneim, Arab Fertilizer Association (AFA)  
Tel : +202 2305 4464 67 Ext: 116  
Email: mz.ghoneim@arabfertilizer.org  
www.arabfertilizer.org

16-18

39th Annual World Methanol Conference – virtual event  
Contact: Jake Barrett, IHS Markit  
Tel: +1 212 709 1316  
Email: Jake.Barrett@ihsmarkit.com  
Web: ihsmarkit.com/events/39th-annual-world-methanol-conference/overview.html

### DECEMBER

7-9

Argus Green Ammonia – virtual event  
Contact: Argus Media Group  
Tel: +44 20 7780 4340  
Email: conferences@argusmedia.com  
Web: www.argusmedia.com/en/conferences-events-listing/green-ammonia

9-10

2021 IFS Agronomic Conference, CAMBRIDGE, UK  
Contact: International Fertiliser Society, Colchester, CO1 9PR, UK.  
Tel: +44 (0)1206 851 819  
Email: secretary@fertiliser-society.org

13-15

Syngas 2021, BATON ROUGE, Louisiana, USA  
Contact: Betty Helm, Syngas Association, Baton Rouge, Louisiana.  
Tel: +1 225 706 8403  
Web: www.syngasassociation.com

### MARCH 2022

21-23

Fertilizer Latino Americano, MIAMI, Florida, USA  
Contact: Argus Media, Ltd  
Tel: +44 (0)20 7780 4340  
Email: conferences@argusmedia.com

28-30

Nitrogen+Syngas Conference 2022, BERLIN, Germany  
Contact: CRU Events  
Tel: +44 (0) 20 7903 2444  
Fax: +44 (0) 20 7903 2172  
Email: conferences@crugroup.com

### CONTENTS

What's in issue 374

### COVER FEATURE 1

The slowing MTO boom

### COVER FEATURE 2

Barriers to trade

### COVER FEATURE 3

Green technologies

### COVER FEATURE 4

Wastewater treatment

NITROGEN+SYNGAS  
**ISSUE 374**  
NOVEMBER-DECEMBER 2022

**BCInsight**

Southbank House, Black Prince Road  
London SE1 7SJ, England  
Tel: +44 (0)20 7793 2567  
Fax: +44 (0)20 7793 2577  
Web: www.bcinsight.com  
www.bcinsightsearch.com



# Plant Manager+

## Problem No. 63 Holding reactor content during a long shutdown

Every urea plant continuously fights against corrosion. The intermediate product ammonium carbamate is extremely corrosive under synthesis conditions. The applied materials of construction require oxygen to form a protective passive layer of chromium oxides. The ammonium carbamate solution will continuously dissolve the passive layer, therefore it is vital to continuously supply oxygen, typically in the form of air, to maintain the passive layer. During blocking-in conditions of the synthesis section it is not possible to add air and the oxygen present will be consumed as a result of the passive corrosion reactions, while at the same time the passive layer dissolves in the ammonium-carbamate solution. At a certain point, the oxygen content in the solution becomes too low to assure a passive layer. At that moment active corrosion will start with much higher corrosion rates than passive corrosion. The picture on the left side shows the passive layer (blue, brown, grey surface) and the picture on the right side shows active corrosion (a shiny silver surface). It is important to realise that once active corrosion starts it cannot be stopped, adding more oxygen at this stage, for example,



will not work. Active corrosion will continue, leading to the risk that the protective layer will be severely damaged. The only way to solve this situation is to drain the synthesis section and re-passivate the surfaces.

**Vijayan Ananthavijayan of Madras Fertilizers Limited in India starts this round table discussion:** During a long shutdown, how many days can we hold the reactor content in the 316L stainless steel-lined reactor? What conditions are required to maintain the reactor content?

**Meer Salman Muddasar of Engro Fertilizer in Pakistan shares his valuable experience:** I assume your reactor will be lined with SS-316L Urea Grade liner, and provided you have maintained the necessary dosing of passivation air during plant operations, you should be able to hold the solution with a pressurised reactor and heated loop for 48 hours. After this period active corrosion initiates. This is a recommended time period we have been applying for the last 20 years without experiencing any material issues in our high pressure loop.

**Mohammad Farooq of SABIC Agri-Nutrients Co in Saudi Arabia joins the discussion:** I agree with the comments above.

**Kashif Naseem of SABIC Agri-Nutrients Co in Saudi Arabia contributes to the discussion:** The holding time of the solution in the reactor depends on the N/C ratio in the reactor and the licensors state periods from 24 to 72 hours.

**Mark Brouwer from UreaKnowHow.com, the Netherlands adds his experience to the discussion:** Please also take the following points into consideration:

- The temperatures should remain higher than 130°C to avoid any risk of crystallisation.
- The condition of the liner is also related to the frequency of stops and starts and blocking in situations.
- A blocking-in situation is always a period of higher corrosion rates as no fresh supply of oxygen is possible and therefore should be avoided whenever possible.

**Meer Salman comes back:** Too low temperatures are avoided by maintaining the high-pressure stripper top temperature, that not only keeps on adding certain heat into the high pressure loop, it also avoids crystallisation.

**Kashif replies:** Mark's points are also very important during blocking-in conditions.

**Sourav Dutta of Matix Fertilizer & Chemical Ltd in India shares his valuable experience:** In addition to this topic of discussion, can you please clarify what actually happens after 48 hours of holding time? How does corrosion accelerate after this time period? Is it due to the decreasing concentration of oxygen that accelerates the corrosion rates?

**Mark replies:** During blocking in, the oxygen content will slowly reduce due to the normal unavoidable passive corrosion. At a certain point the oxygen concentration reaches the critical level and active corrosion starts with higher corrosion rates.

**Prabhat Srivastava of Yara Fertilizer in India shares his valuable experiences:** As per technology licensor recommendations, the high-pressure section can be bottled for up to 48 hours. However, there are situations where the high-pressure section solution has been held for up to 72 hours. If planning in advance to hold the high-pressure synthesis solution more than 48 hours:

- The operator must feed an excess amount of ammonia.
- Immediately bottle the high-pressure section and maintain the pressure higher than 100 kg/cm<sup>2</sup>.

Since there is no option for adding extra oxygen, there is the possibility that urea will partially crystallize at the bottom. To avoid this, ensure flushing of the CO<sub>2</sub> inlet line.

If for any reason the blockage time increases to more than 72 hours then, if possible, feed ammonia for half an hour and maintain the high-pressure synthesis pressure above 100 kg/cm<sup>2</sup> as this will help and excess ammonia will help prevent corrosion.

**Shoaib Minhas of FFBL in Pakistan asks for clarification:** Prabhat, can you please elaborate on point no. 4, how does ammonia help to reduce corrosion at pressures above 100 kg/cm<sup>2</sup> after 72 hours? To my knowledge 72 hours is the maximum allowable time and once active corrosion starts it cannot be controlled or reduced. The only way is by total draining. Please correct me if am wrong.

**Prabhat replies:** Regarding point no. 4: This is not applicable at all times, and it is not the intention to hold for more than 72 hours every time. Sometimes when we have planned some activities it has taken longer than expected. When we feed excess ammonia the small part of unconverted ammonia will overflow, and the flow of ammonia will again make the passivation film. This is the thinking behind the idea, I don't have any actual proof.

**Pradeep Pednekar of RCF Ltd Thal in India shares his valuable experience:** Holding the reactor content during a shutdown for 48 hours is a very safe and proven practice. In a Snamprogetti urea plant passivation is added to the high-pressure stripper by the passivation air compressor. Plant passivation air is also added to the suction line of the CO<sub>2</sub> compressor.

My question is whether it is possible to provide passivation via the passivation air compressor (which is possible with little modification of passivation air lines to reactor feed line) to extend the holding period of the solution during shutdown to some extent?

What will the exact effect be of providing passivation to the reactor metallurgy with this modification?

**Mohammad replies:** The holding time for the urea reactor and synthesis section varies between 48-72 hours. Beyond this period, the passivation layer is affected and once it starts breaking, it cannot be maintained as there is no liquid or gas flow in the synthesis loop. So, in my opinion, feeding oxygen or air will not solve the problem. Addition of ammonia is a second option which may make the media alkaline, but again it can decrease the temperature of the loop which will lead to crystallisation.

**Raja Samar Abbas of Agritech Ltd in Pakistan contributes to the discussion:** The most important parameter is NH<sub>3</sub>:CO<sub>2</sub> ratio of the reactor. Snamprogetti and TOYO urea processes with higher N/C ratios allow the reactor solution to be held, while Stamicarbon prefers to drain it. It is important that if you are shutting down normally and you are going to hold solution that you feed excess ammonia during shutdown and keep the loop pressure higher than 100 kg/cm<sup>2</sup> and the temperature above 120°C to avoid local crystallisation in the reactor and condenser bottom. Periodic flushing is also useful to avoid crystallisation. With a N/C ratio of 4:0 at our plant we have experienced no problems with holding the plant for more than 72 hrs for the last 12 years.

**TK Batra of National Fertilizers Limited in India shares his valuable experiences:** In case hold up is expected to be for more than 24 hours, we keep on injecting ammonia for five minutes every eight hours. This proves to be quite successful.

Nitrogen+Syngas 374 | November-December 2021

# Relax, it's Venti.



## We save energy and improve efficiency.

To modernise existing production systems, Venti Oelde supplies fans equipped with special impellers offering the highest energy efficiency and a reduced sound level. By optimising the inflow and outflow as well as the regulation, Venti achieves considerable energy savings of up to 25%.

### Detailed system check

### Improved cost effectiveness

### High operational safety

High-tech fans  
made  
in Germany



Venti  
Oelde



We make air work for you | [www.venti-oelde.com](http://www.venti-oelde.com)

CONTENTS

What's in issue 374

COVER FEATURE 1

The slowing  
MTO boom

COVER FEATURE 2

Barriers to trade

COVER FEATURE 3

Green technologies

COVER FEATURE 4

Wastewater  
treatment

NITROGEN+SYNGAS  
**ISSUE 374**  
NOVEMBER-DECEMBER 2022

# BCInsight

Southbank House, Black Prince Road  
London SE1 7SJ, England

Tel: +44 (0)20 7793 2567

Fax: +44 (0)20 7793 2577

Web: [www.bcinsight.com](http://www.bcinsight.com)  
[www.bcinsightsearch.com](http://www.bcinsightsearch.com)

The ethylene cracker at the CNOOC/Shell Nanhai petrochemicals complex, Nanhai.

# Chinese ethylene capacity slows the MTO boom



In China, requirements for methanol to produce olefins, mainly propylene and ethylene, from coal, has driven much of the growth in global methanol demand over the past decade. However, a new wave of ethylene cracker investment may put a stop to new MTO plant building.

China has been the key driver of methanol markets over the past two decades, pioneering its widespread use first as a fuel; blended into gasoline for road vehicles or, via its derivative dimethyl ether, blended into LPG for domestic heating, and then over the last decade as a way of using China's vast stocks of coal to replace its imports of olefins via various methanol to olefins (MTO) processes. In so doing, Chinese methanol capacity and demand has come to represent about 65% of the 81 million t/a global methanol industry (see Figures 1 and 2).

According to Methanex figures, of that 81 million t/a, around 14 million t/a (17%, or nearly one third of Chinese demand) has come to be represented by Chinese MTO consumption, and it has become the dominant factor in methanol trade, as several large scale MTO plants have been built without a methanol producing 'front end', but rather relying upon methanol bought on the open

market. It is no exaggeration to say that China's MTO manufacturing has changed the face of the methanol industry. And all of this has happened in a relatively short space of time. China's first large scale coal-to-olefins (CTO) project was commercialised in Baotou, Inner Mongolia in 2010, but since then a further 24 plants have become operational.

## The olefins industry

MTO plants produce a mixture of ethylene and propylene, which are then polymerised to form polyethylene (PE) and polypropylene (PP), the two largest plastics in terms of demand. Polyethylene is used in the packaging, construction and electrical industries, while polypropylene is used in packaging and the fibre industry to make man-made fibres, particularly water resistant ones.

The global ethylene industry produces around 150 million t/a, mainly via the thermal cracking of either naphtha (an oil

derivative) or ethane (a natural gas component). There are over 270 ethylene crackers in service around the world. Propylene is produced as a co-product of ethylene cracking, but it can also be produced as a by-product of refinery fluid catalytic cracking, or via a variety of 'on purpose' methods such as propane dehydrogenation (PDH), which uses liquefied petroleum gas (LPG) as a feedstock, as well as methanol to olefins and methanol to propylene (MTP). On-purpose methods of propylene production have gained ground because by-product propylene production from ethylene production or refineries fell behind propylene demand as it rose faster compared to ethylene demand, leading to a shortfall.

China's rapidly expanding industrial and manufacturing economy saw its domestic demand for PE and PP rise equally rapidly. However, as the country's domestic supplies of oil and gas were limited, this led to increasing imports of both polymers from elsewhere

Fig. 1: Methanol demand by region, 2020

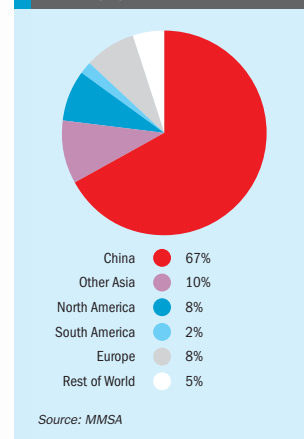

in the world. This in turn led to an attempt by the government to use China's huge domestic coal reserves as a feedstock for olefins production instead, and the easiest route for this was via MTO/MTP. In 2019, the total ethylene capacity from China's MTO units reached 5.21 million t/a, accounting for 21% of China's total domestic ethylene capacity. Even so, that same year, China was only able to supply around 50% of its ethylene requirements, and as a result imported 17.1 million t/a of polyethylene, and this figure rose to an estimated 19.8 million t/a of Chinese PE imports in 2020. However, because of domestic refinery and MTO/MTP production, as well as imports of propane for PDH plants, polypropylene imports were much lower, at around 5.2 million t/a in 2019, and though they rose considerably to 6.6 million t/a in 2020, this is still only one third of the comparable figure for ethylene.

## Filling the ethylene gap

The boom in shale gas production in the United States has led to that country being able to close the gap between supply and demand for natural gas and even become a net exporter, as liquefied natural gas (LNG). However, it has also led to a surplus of higher chain carbon compounds, particularly ethane and natural gas liquids (NGLs) such as propane and butane.

In turn, and in order to try and achieve a greater degree of self-sufficiency in ethylene production (the philosophical ques-

Fig. 2: Methanol supply by region, 2020

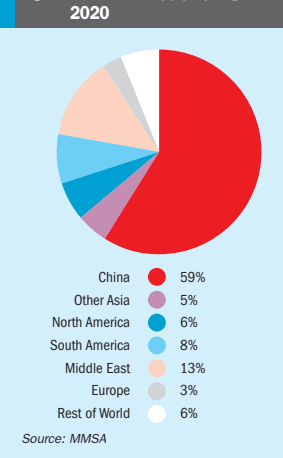

tion of whether a domestic industry based on imported feedstock is actually genuine self-sufficiency we will leave aside for now...) and take advantage of cheap international ethane, in the mid-2010s China therefore began a programme of building domestic ethylene cracking capacity that would be based on ethane.

The first wave of new ethylene capacity came on-stream in 2017, and has accelerated since then. Chinese ethylene capacity rose by 6.8 million t/a to 32 million t/a in 2020, with six crackers completed, and this year sees another eight crackers operational or due to become so, with another 7.8 million t/a of capacity coming on-stream, taking total capacity to just short of 40 million t/a. Between 2020 and 2025, a total of 19 new steam crackers will become operational in China, with a total nameplate capacity of 19.7 million t/a. At the same time, the covid pandemic has seen demand growth slow considerably. At the moment, Chinese cracker capacity is set to take domestic ethylene production from around 58% of demand in 2020 to 83% of forecast demand by 2025, with imports reduced comparably.

There is also considerable investment in ethylene crackers elsewhere in Asia. A total of up to 52 million t/a of capacity could be added across the region between 2020 and 2025, with China only accounting for around half of this. India and Iran also have major capacity additions planned, with India, like China also relying upon imported feedstock. One of the knock-on effects of relying on so

much imported ethane and LPG for feedstock should be to greatly reduce the global surplus of those compounds and therefore decrease availability and increase the price going forward, potentially making Chinese MTO production slightly more competitive.

## The impact on MTO

MTO economics depend upon the relative prices of coal, oil, gas and methanol, and whether the plant is a full coal to olefins (CTO) facility, with control of its own feedstock costs, or simply a methanol to olefins producer, relying upon merchant methanol. Much of China's ethylene production has traditionally been based on naphtha. Therefore, when oil prices are high and coal prices low, CTO producers enjoy a considerable competitive advantage. This was the case in China from around 2010-2014, when the first wave of CTO capacity was built. Methanol prices on the world market, which impacts Chinese domestic methanol prices due to its ease of shipping, tend to depend upon the difference between gas and oil prices. Because of its increasing fuel uses, methanol prices often move in tandem with oil, whereas the margins for producers in a major exporting region such as the Middle East depend on cheap gas prices relative to oil.

A look at the price graph on page 7 of this issue will show that methanol prices were high from around 2011-2014 and again from 2017-2019, and this impacted upon the production economics of merchant MTO producers, especially near coastal regions, many of whom were forced to curtail production in 2018, when MTO operating rates fell to 78%. There has been very limited interest or investment in merchant MTO production for a couple of years - the last two projects, including one at Tianjin Bohai, came on-stream this year. There has also been an attempt by some MTO producers to take advantage of low gas prices in the US by building dedicated methanol capacity there for export to China. However, the ongoing rumbling trade disputes between the US and China and US local opposition to new chemical facilities have effectively killed many of the projects, especially the large Northwest Innovation Works plans for 20,000 t/a of methanol capacity in the Pacific Northwest.

Meanwhile, CTO economics have been impacted by rising coal prices. New investment in China has also been deterred by concerns around environmental and water supply issues. CTO producers can still compete at



present with US ethane crackers. Even so, the huge investment in Chinese ethylene capacity will reduce the profitability of ethylene production from MTO and CTO producers. Wood Mackenzie has predicted that: "prices of olefins and their derivatives will be under pressure from now until 2025 due to massive cracker complex investment. This will restrict the profitability of MTO units. We expect the margins of standalone MTO units or those integrated with heavily-invested commodities to be between break even and negative until 2024 before margins recover."

MTO producers remain towards the top of the ethylene cost curve, and there is an expectation that there may well be a shakeout, with larger, more efficient producers and/or those integrated with higher value derivatives more likely to weather the storm. IHS has gone further, and suggested that merchant MTO operating rates may fall below 70% in 2022, with difficult operating conditions persisting into 2026.

### China's methanol demand

At the moment, the worst has not yet happened for Chinese MTO producers, with operating rates averaging 82% during 2020, and keeping methanol demand relatively high. Outside of methanol for MTO production, China is a major consumer for fuel blending, and the production of fuel additives such as methyl t-butyl ether (MTBE), as well as for more "traditional" chemical demand uses for methanol such as formaldehyde and acetic acid. Methanol blending into gasoline remains a major use, but a national standard outside of the coal-rich methanol producing provinces remains elusive. There is also potential competition from an ethanol blending mandate, and methanol use as a blendstock has actually fallen over the past couple of years.

All of this, and the forthcoming glut of new Chinese olefins production, points towards

### New ethylene catalyst

Another competitor for MTO may be a new catalyst launched in early October by Clariant in conjunction with Linde Engineering. The new catalysts achieve the low emission oxidative dehydrogenation of ethane in a commercially feasible manner due to a step change in selectivity and productivity. Clariant's ODH catalysts are designed exclusively for Linde Engineering's EDHOX™ catalytic on-purpose ethylene technology. In contrast to conventional steam cracking, which operates at process temperatures up to 900°C, EDHOX™ operates at temperatures below 400°C, enabling comparatively low CO<sub>2</sub> emissions, as well as potential sequestration of CO<sub>2</sub>. The new catalysts offer high selectivity to ethylene and acetic acid (up to 93%) while also minimising the formation of by-products. ■



a more challenging future for methanol than has been the case historically. At last year's World Methanol Conference, Mike Nash of IHS noted that demand for methanol worldwide was actually projected to fall below GDP growth for 2020, and suggested that it might rise at only around 2.8% year on year during the 2020s, compared to global GDP growth of 3.2% per year. However, Methanex is projecting much rosier forecasts of an increase in methanol demand by 4% year on year over the same period. Certainly, demand continues to be robust in China for the time being; even though Chinese methanol production rose by about 8% in 2020 in spite of losses caused in the first half of the year due to the pandemic, lower methanol prices and lack of feedstock availability, overall demand remained robust and imports still reached a record level in 2020 of 13 million t/a, up from 10.9 million t/a in 2019.

On the capacity side, there is still new Chinese methanol capacity being built,

much of it tied to downstream CTO production, including the new Ningxia Baofeng Energy plant, which is due to have a capacity of around 500,000 t/a of CTO and 500,000 t/a of C2-C5 utilisation, making it the largest single train MTO plant in the world, and including up to 1.5 million t/a of methanol capacity. Two more MTO plants are being backwards integrated into new coal to methanol units to become CTO rather than MTO producers. Methanol demand for Chinese CTO production will rise by about 3 million t/a by 2025, and overall, around 6.6 million t/a of methanol is due to come on-stream in China in the period 2020-2025, although this will be balanced by some capacity rationalisations. Around 1 million t/a of older, less efficient capacity using older gasification technology which requires more expensive anthracite coal feedstock rather than cheaper bituminous coal is expected to close over the same period.

### The impact on methanol markets

At the moment, Methanex is projecting around 14 million t/a of new methanol capacity being commissioned in the 2021-25 period (see Table 1) and sees an additional 16 million t/a of new demand over that period, leaving the market short of 2 million t/a to be recovered in improved prices and operating rates. However, as the new Chinese ethylene (and some propylene) capacity starts up, this may have a significant impact on Chinese MTO production, and as a result curtail methanol demand. ■

Table 1: New global methanol capacity 2021-25

Country	Plant	Capacity (million t/a)	Start-up
United States	Koch	1.7	2021
	Methanex Geismar 3	1.8	2023-24
	Others*	0.8	2021
Iran	Sabalan	1.7	2021-22
Russia	Shchekinoazot	0.5	2022
China	Various	6.6	2021-22
<b>Total</b>		<b>14.1</b>	

\*US Methanol, Geismar 2 debottleneck

Source: Methanex

# Make your plant fit for the future



100 years ago, Friedrich Uhde saw a huge demand for ammonia to ensure food supplies. That was the birth of Uhde in 1921. Today, thyssenkrupp Uhde is a choice provider of one-stop solutions for upgrading your grey ammonia plant to blue and/or green ammonia. We do this by taking our vast experience in the uhde® ammonia process and adapting it with our uhde® alkaline water electrolysis for green ammonia and with our uhde® CO<sub>2</sub> sequestration unit for blue solutions. But the story does not end here because thyssenkrupp uhde also offers you best-in-class solutions in fertilizer and methanol technologies to shape you up for the future. We have been your valued partner for a century and we are there for the future, too.

[www.thyssenkrupp-industrial-solutions.com](http://www.thyssenkrupp-industrial-solutions.com)



engineering.tomorrow.together.



thyssenkrupp

CONTENTS

What's in issue 374

COVER FEATURE 1

The slowing MTO boom

COVER FEATURE 2

Barriers to trade

COVER FEATURE 3

Green technologies

COVER FEATURE 4

Wastewater treatment

NITROGEN+SYNGAS  
**ISSUE 374**  
NOVEMBER-DECEMBER 2022

**BCInsight**

Southbank House, Black Prince Road  
London SE1 7SJ, England

Tel: +44 (0)20 7793 2567

Fax: +44 (0)20 7793 2577

Web: [www.bcinsight.com](http://www.bcinsight.com)

[www.bcinsightsearch.com](http://www.bcinsightsearch.com)

# Barriers to trade

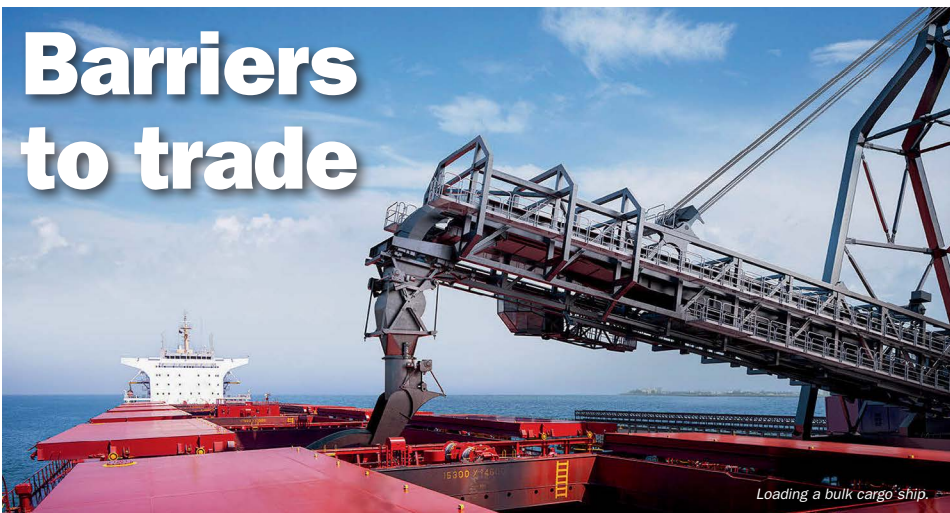

PHOTO: SIMPTEL  
Loading a bulk cargo ship.

With globalisation seemingly in retreat, the protectionist impulse is seeing a rise in barriers to trade, from quotas and tariffs to anti-dumping actions and domestic subsidies.

Since the Second World War, and especially over the past three decades, the global trade of goods rapidly increased. Over the past century and a half, periods of expansion of international trade have alternated with periods of retrenchment and protectionism. The first great boom in global trade came during the late 19th century with the rapid industrialisation of Europe and North America and the growth of rail and steamship transport, as well as the expansion of colonial control over regions such as Africa and Asia, but ended with the terrible carnage of the First World War. Depression, protectionism and the Second World War saw global trade as a proportion of GDP fall to just 5%. However, economic integration rebounded after the Second World War and continued to increase for the latter half of the 20th century. An embrace of economic liberalisation saw the removal of trade barriers in large emerging markets and led to unprecedented levels of international economic cooperation, with the global trade: GDP ratio peaking in 2008 at 61%.

Since this era of peak globalisation, however, the fallout from the world financial crisis has accompanied increasing tensions over trade, particularly between China and the US, and an increase in global trade barriers, exacerbated over the past two years

Fig. 1: Global trade: GDP ratio

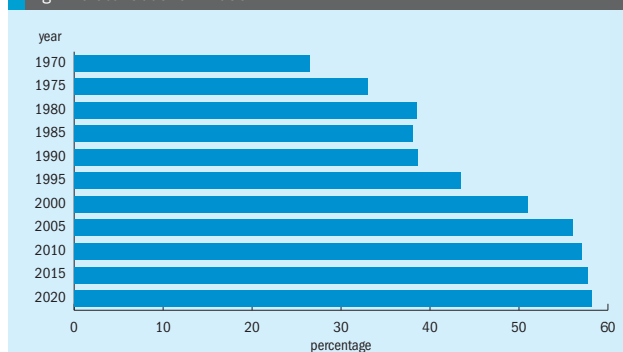

Source: World Bank

by the Covid pandemic. Global trade: GDP ratios have fallen to 53.5% in 2017, though rebounding to 58% in 2019, according to World Bank figures (Figure 1).

## Barriers to trade

Barriers to international trade can be summed up as falling into one of three categories. The first is what might be termed

'natural' barriers – long distances, poor infrastructure such as roads, rail or bottlenecks at ports, linguistic or cultural barriers, or comparative advantage that makes domestic products cheaper to produce than imported products.

The second broad category are financial barriers, specifically tariffs or subsidies. The purpose of tariffs or subsidies is usually to try and advantage less competitive domestic

producers against competition from overseas producers by adding to the price of imports. Industries can be protected for a variety of reasons, from attempting to increase competition by letting domestic champions emerge, maintaining employment, especially in vulnerable communities such as rural areas, and other attempts to maintain domestic self-sufficiency for strategic reasons, and increasingly these days for reasons of health, welfare or the environment.

Finally, there are non-tariff barriers which seek to restrict trade, such as import quotas or embargoes – the latter again usually for geopolitical and/or strategic reasons. Other non-tariff barriers can e.g., mandate purchasing rules for domestic consumers, or setting standards which can only be met easily by domestic producers.

## The WTO

The rapid expansion of international trade in the post-war period has been driven by the development of a rules-based international trading system, beginning with the General Agreement on Tariffs and Trade (GATT) just after the war, which eventually became the World Trade Organisation (WTO) in 1995. Agriculture was actually a relative latecomer to the WTO system, as domestic food security and the fate of rural communities is often a highly politically-charged area in many countries, and markets were therefore protected through tariffs, quotas, or outright bans on imports. Domestic support to agriculture, particularly among rich developed countries such as the US, Japan, and the EU, was large and growing.

However, the success of the 1986-1993 Uruguay Round discussions eventually produced the global Agreement on Agriculture (AoA), which brought clarity to areas such as market access, domestic support, and export competition. Under the agreement, members agreed to abolish non-tariff barriers and instead convert them to tariff equivalents, a process called 'tariffication' and, where necessary, guarantee minimum access to domestic markets via tariff-rate quotas (TRQs). Developed countries were required to cut tariffs by an average of 36% over six years, and developing countries 24% over 10 years. Several developing countries also used the option of offering tariff ceilings. Export subsidies were capped and reduced, and at Nairobi in 2015, WTO mem-

bers further agreed that developed countries would immediately remove export subsidies except for on a handful of products, and that developing countries would do so by 2018. Domestic support levels were also subject to reduction commitments and countries were encouraged to adopt support policies that had minimal production- and trade-distorting effects and that were exempt from reduction commitments (so-called 'green box' policies).

The result has been a tripling in global agricultural exports by value (doubling by volume) from 1995-2018, reaching \$1.8 trillion that year. However, progress since the Uruguay Round has been limited. The Doha Development Agenda (DDA) was launched in 2001, but members failed to reach agreement in 2008 and the trade agenda in Geneva has since advanced slowly. Just this year, in July, the WTO's director-general Ngozi Okonjo-Iweala used a speech at a meeting with World Bank president David Malpass to argue that agricultural subsidies, especially those in rich countries, continue to distort global trade and create unfair competition for farmers in poor countries. The UN estimates that global support to farm producers totals \$540 million per year, and could triple to \$1.8 trillion by 2030. Malpass used the same occasion to reference fertilizer subsidies in particular, saying that they can distort which crops are grown as well as encouraging overapplication, leading to eutrophication. The remarks were seen as a steer ahead

of the 12th ministerial meeting of the WTO members in Geneva, which will be held from November 30th to December 4th this year, postponed from last year because of the covid pandemic.

## The 'appellate crisis'

One of the key issues for the WTO at the moment is its dispute settlement mechanism, which has also covered agriculture since the completion of the Uruguay Round. When two WTO members have a dispute over the legality of any trade measure, they can refer the case to the WTO's Dispute Settlement Body, comprising all member states, which then establishes a dispute panel which can arbitrate on the case. However, if one party is unsatisfied with the resolution, it can refer the case to the WTO Appellate Body, which functions

as a final court of appeal. However, two of the members of the 7-person Appellate Body completed their terms in 2019, and the US has been blocking new appointments to it over a series of grievances with the WTO, including questions of delay, judicial over-reach, precedence, and transition rules. While the move was instigated by the Trump administration, this is an area where the Biden administration has continued the same policy, and it stems in no small part from ongoing rivalries with China. In the interim, the Appellate Body is unable to hear new appeals.

To find a temporary solution to the impasse, the EU and China and a number of other member states have set up a multi-party interim appeal arbitration arrangement (MPIA). The parties continue to seek resolution of the Appellate Body crisis, and agree to use the MPIA as a second instance as long as the situation continues. However, unless the matter can be resolved, the WTO may actually face an existential crisis.

## China

Though it is some way down the list compared to disputes over e.g. steel and aluminium, fertilizer has also actually been one of the sticking points between the US and China. China acceded to the WTO in 2002, and in its accession agreement China agreed to implement a system of tariff rate quotas (TRQs) designed to provide significant market access for key industrial products, including phosphate fertilizer, a major US export. Under the TRQ system, a set quantity of imports is allowed at a low tariff rate, while imports above that level are subject to a higher tariff rate. The quantity of imports allowed at the low tariff rate increases annually by an agreed amount. However, the US has expressed concerns about Chinese government policies promoting domestic fertilizer production, including export duties and the exemption of diammonium phosphate from 13% VAT.

## India

India acceded to the WTO in 1995 and was a member of GATT from 1948 onwards. However, it has faced criticism for its subsidy policy on domestic fertilizer production. India gave \$22.5 billion as agricultural input subsidies in the 2017-18 financial year, including support for irrigation, fertilizers and electricity. However, in response, India points out that its agricul-

**Agricultural subsidies... continue to distort global trade.**

## CONTENTS

What's in issue 374

## COVER FEATURE 1

The slowing MTO boom

## COVER FEATURE 2

Barriers to trade

## COVER FEATURE 3

Green technologies

## COVER FEATURE 4

Wastewater treatment

NITROGEN+SYNGAS  
**ISSUE 374**  
NOVEMBER-DECEMBER 2022

**BCInsight**

Southbank House, Black Prince Road  
London SE1 7SJ, England

Tel: +44 (0)20 7793 2567

Fax: +44 (0)20 7793 2577

Web: www.bcinsight.com  
www.bcinsightsearch.com



tural census of 2016 showed that 99.4% of all farm holdings in the country were low-income or resource poor farmers, and that in consequence the country will not accept any limits on subsidies on farm inputs such as seeds and fertilizers.

There is also a sense of injustice in that – unlike some of the richer countries such as the EU, US and Canada – countries such as India and China do not have access to permitted Aggregate Measurement of Support (AMS) measures, which are supposed to be slowly capped, reduced and eliminated. India and China say that AMS measures, such as the EU’s Common Agricultural Policy, currently provide \$160 billion in subsidies to developed world farmers every year. India says that were it allowed to draw down subsidy in the same way as AMS measures, its subsidies are well below permitted levels.

Russia

Russia did not accede to the WTO until 2012. Prior to that, the European Union and United States had long argued that Russian fertilizer producers benefitted from artificially low natural gas prices, leading to so-called “dumping” of cheap product on western markets at below what should be a ‘natural’ cost price, and in return imposed a series of anti-dumping tariffs against Russian ammonium nitrate and other products during the 1990s and 2000s, amounting to around \$32/tonne as per its last revision. However, the Russian gas industry has changed considerably since the collapse of the Soviet Union in 1989, and there is much more competition and market-related pricing in the industry now. Indeed, Russia has actually found itself benefitting from WTO adjudications recently, with a case brought last year in the WTO which ruled that existing EU anti-dumping duties on Russian AN were illegal and should be removed, as they used an outdated methodology for deciding what a “fair” price for gas inputs should be. However, the EU and UK both reaffirmed their anti-dumping duties in December 2020 following a review. India also maintains anti-dumping duties on Russian AN, although it is a much smaller consumer of it than the EU.

European Union

In addition to criticisms over its Common Agricultural Policy, there is a suspicion in some quarters that the EU is also beginning

to use environmental measures to privilege its domestic industry. In December 2019, the EU proposed to introduce a carbon border adjustment mechanism (CBAM), a form of carbon pricing on imports into the EU, as part of the European Green Deal. The rationale behind the initiative is an attempt to address the risk that the EU’s efforts to curb greenhouse gas (GHG) emissions will be undermined by a lack of climate ambition in non-EU countries due to so-called “carbon leakage” – a situation when stronger climate policies in one jurisdiction lead to increased GHG emissions in other jurisdictions. It will target listed products from six carbon-intensive sectors, and nitrogen fertilizer production is one of those. The EU has talked of implementing the CBAM by 2026.

The CBAM was the subject of discussion at the WTO Committee on Trade and Environment (CTE), in March this year, and a number of members stressed that it needs to be designed in a transparent way, and different levels of development should be considered to address trade distortions. However, the EU says that under the proposal, countries with their own emissions trading systems such as Norway and Iceland could gain levels of exemption from CBAM, and the UK and China may also qualify if they link their national trading schemes to the EU ETS. The measure could spark greater interest in emissions trading schemes more generally. Canada and Japan, and possibly even the US are also said to be considering similar carbon border taxes. Much may depend upon what emerges from the COP-26 talks in Glasgow this autumn.

Africa

Africa remains the only continent not to have profited from a ‘green revolution’ in fertilizer use and food production in the same way that South America and Asia did from the 1970s onwards. In 2006 a meeting of the African Union made the Abuja Declaration, which called for 6% annual growth in agricultural production as a framework for the restoration of agricultural growth, food security and rural development in Africa. One of the concrete measures to be adopted was harmonisation of policies and regulations to ensure duty- and tax-free movement across regions, and the elimination of taxes and tariffs on fertilizer and on fertilizer raw materials.

Fifteen years on, progress remains very slow on achieving these goals. Standards

and regulations, and non-tariff barriers (NTBs) continue to be a major bottleneck to trade and consumption of fertilizers, though these barriers can include poor infrastructure for transport and distribution. Urea production in Nigeria increased from less than 1 million t/a in 2015 to over 4 million t/a in 2018; sufficient to satisfy most of the demand for fertilizer in the rest of sub-Saharan Africa. However, as a result of prevailing local tariff and non-tariff barriers, over 80% of Nigeria’s urea is exported to Brazil and Argentina.

However, the African Continental Free Trade Area (AfCFTA), which came into operation in January 2021 under the auspices of the African Union, and currently ratified by 38 countries, may be a step to tackle this at last. It requires members to remove tariffs between member states on 90% of goods, and could boost inter-African trade by more than 50% within a couple of years.

Feeding the world

The growth in global trade has impacted many areas, and agricultural trade has been no exception, with the value of world trade in agricultural products having now increased to around \$1.8 trillion per year. However, the UN Food and Agricultural Organisation (FAO) projects that global food demand will increase by as much as 50% from 2012-2013 levels by 2050, as trends in population growth, urbanisation, and income growth continue, particularly in developing countries. Population projections by the United Nations suggest that 98% of the population growth expected between 2015 and 2050 will come from developing countries, with sub-Saharan Africa accounting for more than 55% of that growth. Income growth rates and urbanisation rates are also projected to be higher in developing countries, so that much of the global demand growth for meats, dairy, fruits and vegetables, and processed food products will continue to come from these economies. This could also be true for fertilizer demand growth, perhaps balancing losses from more efficient use elsewhere, but it will require the continued lowering of tariff and non-tariff barriers to trade. However, as this article has discussed, in order to achieve this there are a number of issues outstanding, from the Appellate Crisis to Aggregate Measurement of Support calculations and the impact of cross-border carbon taxes which need to be urgently addressed.

# Modular plant design



PHOTO: PRIMUS GREEN ENERGY

A move towards smaller scale feedstocks such as renewable energy and waste and biomass gasification is leading to increased focus on improving the efficiency of small-scale, modular plants.

Left: Primus Green Energy’s small scale modular methanol plant design.

Construction of a chemical process plant as several pre-built modules which are then transported separately to a final site and assembled is not a new concept. However, modularisation is seeing an increase in interest in the ammonia and methanol industries for a variety of reasons.

Primary among these is the move to smaller scale feeds for a syngas plant. Previously the industry had moved towards large scale plants to capture economies of scale, and plants are still offered and (at least on the methanol side) built with capacities of up to 7,000 t/d. But these rely upon access to either large coal deposits - an increasingly untenable option in today’s world without some form of associated carbon capture and storage - or large scale natural gas feeds. But large gas feeds are becoming scarcer; the growth of the global LNG market means that large gas deposits usually prioritise LNG export where possible. Where ‘stranded’ gas is still available, it is often from either flared gas from oil deposits or isolated shale gas wells, where the amount of gas available is much smaller.

And then there is the move towards more environmentally friendly production, either through gasification of municipal waste or waste biomass, or from hydrogen generated by electrolysis using renewable energy. All of these operate on much

smaller scales than would be required to feed a modern world-scale ammonia or methanol plant.

Smaller scale production makes plant financing easier, and also opens up the option of modularisation. This can offer a number of potential advantages compared to conventional construction. To begin with, it means that most of the construction work can be carried out in a carefully managed environment, reducing risks and leading to increased construction safety and productivity, leading to lower costs and shorter lead times. It minimises site preparation such as foundation laying and reduces the time needed to rent large cranes and the like. It also reduces the number of skilled workers required to assemble the plant, which can be a limiting factor, and can reduce the difficulty of transport of large equipment items to remote areas. At the very smallest scales, modules can be built to standard ISO container sizes, making transport very cheap and easy.

There are drawbacks as well. Module construction requires more steel than traditional construction, because each module needs to be designed and built to stand independently and to withstand the stresses of being transported, lifted, and erected. The units are therefore structurally stronger than conventional units constructed onsite, but more expensive.

Furthermore, without the advantages of large throughput, the capital intensity of each tonne of ammonia or methanol produced is usually higher for a smaller scale plant. However, if it offers the possibility of being produced closer to an end use market because it is using more environmentally friendly technologies, rather than a remote low gas cost location, then what it loses in capital cost it may recoup in reduced transport costs and potentially lower operating costs. Most major plant licensors now offer modular options for small scale (less than about 300 t/d) plant design and construction, and where modularisation offers the possibility of building multiple copies of the same equipment item, then this may also bring overall costs down. Small scale production can require a rethink of the entire process, but in so doing also open up the possibilities of using, e.g. microchannel reactors, plasma flames, semi-permeable membranes and other innovative design features which can bring costs down, by lowering temperatures or pressures required to achieve synthesis.

At the moment, many of these small scale modular plants are at the pilot or demonstrator plant stage, and there has not been a large-scale take-up. However, the current push to decarbonise chemical production may just provide the impetus that the industry needs to adopt widespread use of smaller scale, modular production.

CONTENTS

What’s in issue 374

COVER FEATURE 1

The slowing MTO boom

COVER FEATURE 2

Barriers to trade

COVER FEATURE 3

Green technologies

COVER FEATURE 4

Wastewater treatment

NITROGEN+SYNGAS  
ISSUE 374  
NOVEMBER-DECEMBER 2022

## BCInsight

Southbank House, Black Prince Road  
London SE1 7SJ, England  
Tel: +44 (0)20 7793 2567  
Fax: +44 (0)20 7793 2577  
Web: www.bcinsight.com  
www.bcinsightsearch.com

# Green technology progress for a more sustainable future



Reducing carbon footprint in the synthesis of chemicals is a new challenge, a necessary requirement in the pursuit of sustainable products designed to minimise environmental impacts during their whole lifecycle. So-called “green” technologies for ammonia, methanol and hydrogen are being developed to meet these challenges. Casale, Linde, thyssenkrupp Industrial Solutions, Toyo Engineering Corporation, Haldor Topsoe and Stamicarbon report on some of their latest developments.

## CASALE

### Casale green technologies

Green ammonia, hydrogen and methanol will become increasingly important as the world works towards the goal of sustainable power production which minimises environmental impacts and carbon footprint.

For several years, Casale has been active in the development and optimisation of new green technologies for the production of ammonia and methanol, two of the most energy intensive chemical products, responsible for the emission of large quantities of CO<sub>2</sub>.

Casale can design and deliver the full scope for green ammonia and methanol plants including the converter, synthesis loop and optimal balance of the plant configuration.

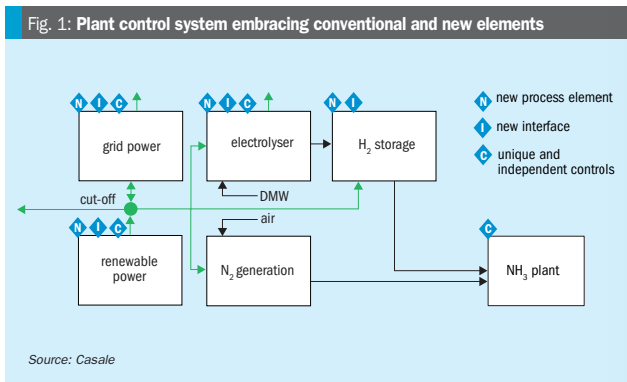

## ONE PARTNER for all your needs



### OUR INTEGRATED PROCESSES

From feedstocks to any fertilizers and valuable chemicals delivering end-to-end quality for you

#### CONTENTS

What's in issue 374

#### COVER FEATURE 1

The slowing MTO boom

#### COVER FEATURE 2

Barriers to trade

#### COVER FEATURE 3

Green technologies

#### COVER FEATURE 4

Wastewater treatment

NITROGEN+SYNGAS  
**ISSUE 374**  
NOVEMBER-DECEMBER 2022

## BCInsight

Southbank House, Black Prince Road  
London SE1 7SJ, England  
Tel: +44 (0)20 7793 2567  
Fax: +44 (0)20 7793 2577  
Web: www.bcinsight.com  
www.bcinsightsearch.com



Casale currently leads several research projects on green technologies and is engaged in a large number of proposals with capacities in the range 3-5,000 t/d.

### Casale green ammonia

Today Casale offers a wide range of modern technologies focused but not limited to ammonia, and embracing the full scope of green ammonia production.

Casale is also an engineering supplier of components for other sections of the green ammonia plant such as hydrogen storage, ammonia storage, as well as solutions for green plant digitalisation and optimisation, and solutions for green ammonia use, ammonia cracking to hydrogen or conversion into nitrogen fertilizer.

A major difference of a green ammonia plant compared to a conventional (grey) ammonia plant is that the energy comes from a renewable source, which often fluctuates, also resulting in fluctuations of hydrogen and nitrogen. The intermittency of the power supply requires the ammonia plant to be more flexible, otherwise the process will suffer from operational interruptions, and impact on the production cost by requiring more capex to stabilise the fluctuations. To cope with such challenges the green ammonia plant comes with new elements (e.g. electrolyser, H<sub>2</sub> storage), new interfaces between those elements,

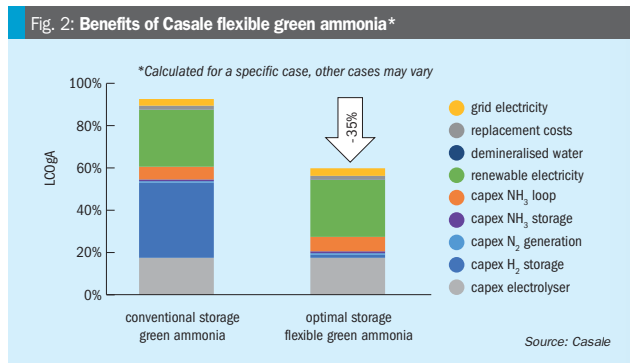

and a unique control system compared with a conventional process (Fig. 1).

Profile fluctuations vary according to location and power source. It is therefore important to work from real power input profiles for green ammonia.

Casale has mastered the understanding of dynamics in green ammonia production under variable power input to develop a uniquely flexible green ammonia solution, which delivers a significant cost advantage over conventional non-flexible green ammonia synthesis by requiring less hydrogen storage capacity.

Casale has developed new dynamic tools specifically for this purpose:

- **gNH<sub>3</sub> Optimiser:** this tool provides optimal component pre-sizing, energy utilisation, and optimised control of the whole process to the target levelised cost of ammonia, based on yearly power profiles and leveraging flexible Casale design features of 10-110% load flexibility with >100% per hour load change.
- **gNH<sub>3</sub> Dynamic Model:** this tool is a dynamic process model of the plant which can simulate the process using scenarios from real fluctuations of the power profile. It allows fine tuning of the system, troubleshooting and scheduling.

Fig. 3: Casale green methanol process

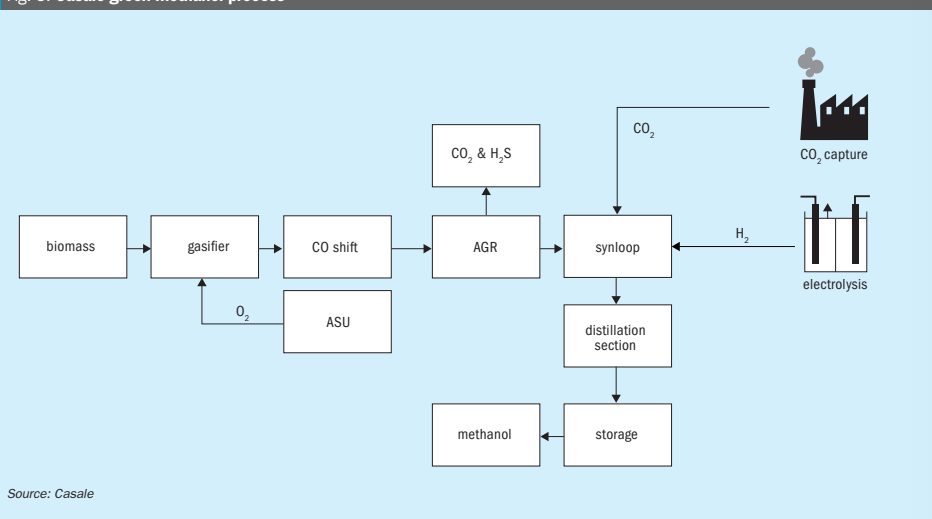
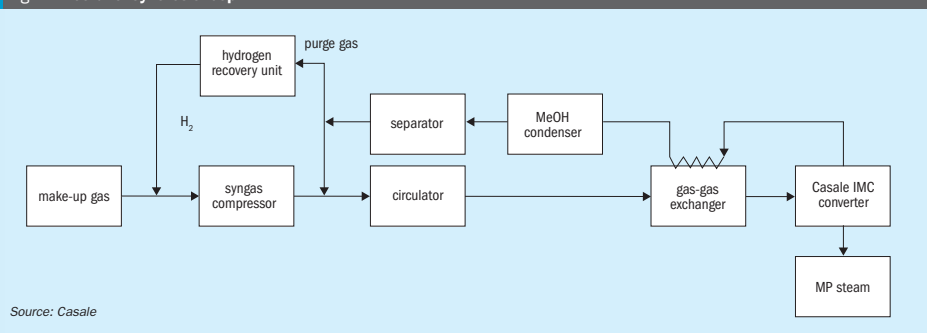

Fig. 4: Methanol synthesis loop



Using these tools, Casale is able to find the optimal solution with lower capex and opex, for a given power profile and other input parameters (electricity cost, electrolyser capex and efficiency, etc.). These tools select the type of sub technologies to be integrated into a green ammonia process and permit customers to make short- and long-term investment decisions.

Casale's flexible patent pending green ammonia process combines control and process technology to convert real fluctuating power profiles into green ammonia which is validated by these tools.

Loop flexibility is achieved with a patented solution for the control of the ammonia synthesis converter and the use of Amomax™-Casale synthesis catalyst.

With a conventional nonflexible or "rigid" loop, fluctuations of the power input (feedstock flow) are absorbed by a huge and expensive hydrogen storage unit that guarantees constant operation of the loop at 70-110% of the load.

With the "flexible" loop offered by Casale the fluctuations are absorbed by a smaller hydrogen storage unit and the loop is operated at 10-110% load. The size of the hydrogen storage unit and the loop are

cost optimised and tailored to the input power profile.

Through the analysis and optimisation of real, project-specific, power input profiles, and with the aid of Casale dynamic tools, a tailored flexible green ammonia plant can be designed, resulting in the lowest levelised cost of green ammonia, embracing the full scope, and operating based on real profiles.

Fig. 2 shows the benefits of Casale flexible green ammonia compared to non-flexible green ammonia production calculated for a specific PV solar energy case in the US.

In this case study, a 35% reduction of the levelised cost of ammonia is achieved with the Casale flexible green ammonia process compared to a conventional one.

A stream of green hydrogen from electrolysis or biomass gasification can also be integrated into a standard ammonia plant to achieve partial decarbonisation of the production. If the hydrogen source is not steady (e.g., H<sub>2</sub> from electrolysis using PV electricity) Casale dynamic tools can be used to cost optimise the energy utilisation and plant modifications to provide a stable plant operation throughout.

Table 1: Green methanol key performance indicators

	Biomass gasification	H <sub>2</sub> + CO <sub>2</sub> feedstock
Loop pressure, MPa g	7-9	5-8
Delta CH <sub>3</sub> OH, %	6-10	4-8
Steam production, t/t	1.0-1.3	0.5-1.0
MUG H <sub>2</sub> /CO <sub>x</sub>	2-2.5	2.5-3
Circulation/MUG, mol/mol	2.5-3.5	3-4

Source: Casale

### Casale green methanol

Green methanol (or bio-methanol) may be produced via biological pathways (anaerobic digestion), thermo-chemical pathways (gasification) or electrofuel pathways (power to gas).

The biomass gasification route leads to a plant which is similar to a coal gasification plant, for which Casale has almost 20 references in China.

For these types of plant Casale can provide the CO-shift section, synthesis loop, distillation, and storage.

Green methanol from hydrogen from electrolysis and CO<sub>2</sub> recovered from flue gases is also feasible. In this case the reactivity of the feed gas is much less than gasification route, despite the low inert content.

A combination of the two routes is also possible. Fig. 3 shows a block diagram for a green methanol process.

Overall, the synthesis loop can be very simple. It consists of the synthesis converter, a gas-gas exchanger preheating the reacting gas entering the converter, a condenser to cool down the gas to the methanol condensation temperature, a separator to separate the liquid raw methanol from the unreacted gas, a purge recovery unit to recover hydrogen from the purge gas so as to correct the stoichiometric number for biomass gasification plants, and the syngas and circulating compressor.

There are six main items overall, to which a guard bed may be added on the make-up gas for protection from possible spikes in poisons content.

Fig. 4 shows a block diagram for the methanol synthesis loop and Table 1 provides the key performance indicators for green methanol.

CONTENTS

What's in issue 374

COVER FEATURE 1

The slowing MTO boom

COVER FEATURE 2

Barriers to trade

COVER FEATURE 3

Green technologies

COVER FEATURE 4

Wastewater treatment

NITROGEN+SYNGAS  
**ISSUE 374**  
NOVEMBER-DECEMBER 2022

**BCInsight**

Southbank House, Black Prince Road  
London SE1 7SJ, England  
Tel: +44 (0)20 7793 2567  
Fax: +44 (0)20 7793 2577  
Web: www.bcinsight.com  
www.bcinsightsearch.com

## LINDE

## Linde green ammonia production

Michael Reinke, Albrecht Heinzl.

Numerous legislative decisions regarding the reduction of greenhouse gas emissions require a transition from the current fossil fuel based electrical energy generation towards an environmentally friendly renewable energy production. The location- and time-dependent availability of renewable energy requires energy storage and transport. Green ammonia meets these requirements. The Linde Ammonia Concept (LAC™) can be a key component in today's and future sustainable energy production and storage.

The United Nations (UN) agreed to limit global warming below 1.5°C at the 2015 UN Climate Conference and the European Union (EU) committed to climate neutrality by 2050. In light of these decisions, green ammonia is a promising opportunity to transport energy at reasonable costs from remote global regions with large green power availability to areas with high energy demand. Furthermore, a fall back on an already existing infrastructure for transportation, storage and distribution is possible.

Up to now traditional ammonia production technology has been mainly based on the processing of fossil feedstocks, whereby the feedstock is converted by means of a thermochemical conversion process to a hydrogen-rich synthesis gas. The carbon from the feedstock is released as carbon dioxide to the atmosphere or to some extent temporarily bound if it is used downstream for the production of urea fertilizer.

Since all required technologies for small scale, as well as large scale, are commercially available, the possibility to use green ammonia as a zero-carbon fuel and energy carrier is a very attractive approach. Although ammonia production is a proven technology, the process setup for green ammonia production needs to be adapted and optimised to meet the challenge of zero-carbon energy storage applications. The major process modification affects the syngas generation. Green ammonia needs green hydrogen. The hydrogen has to be generated in electrolyser units which are powered by renewable energy. The optimisation challenge is to tune the process in such a way, that it can handle fluctuations in renewable power availability and still be efficient at a minimum capital expense.

Fig. 1: 3-day summer/winter profile for electric power consumption and production in Germany, sorted for different types of power generation<sup>1</sup>

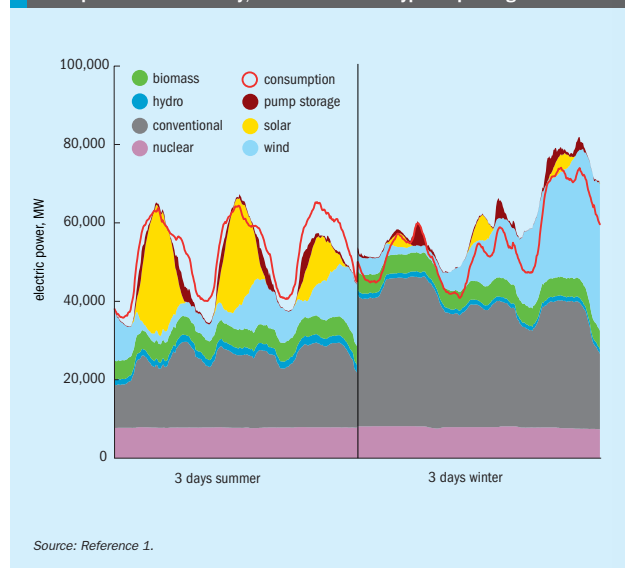

Source: Reference 1.

Fig. 1 represents data depicting a large discrepancy between the electrical power consumed versus the electrical power produced by renewable energy sources. Currently the difference is compensated by adapting the power production from fossil fuels.

In light of the committed greenhouse gas reduction goals the conventional CO<sub>2</sub> emitting power generation plants (e.g., coal-fired power plants) need to be replaced by renewable energy plants. A simple one-to-one replacement of fossil fuel derived power production with wind and solar power is not a viable option due to dependency of power production based on weather conditions. Obviously, it is therefore necessary to decouple the power consumption from the non-deterministic intermittent wind and solar energy availability. Thus, green ammonia or green hydrogen as energy carriers can help to resolve the dilemma between renewable power production and power demand, which are usually not completely congruent with respect to timing and the location of production and consumption.

### Ammonia as an intercontinental energy carrier

Fig. 2 shows a potential example for an ammonia-based intercontinental energy carrier route utilising renewable power to produce hydrogen and ammonia to distribute to consumers.

Electric energy generated by means of renewable power (e.g. solar, wind, etc.) is used to produce high purity hydrogen via water electrolysers as supplied by ITM Linde Electrolysis. High purity nitrogen is generated from air separation units, e.g. FLEXASU® as supplied by Linde. Subsequently pure hydrogen and nitrogen are fed in a molar ratio of H<sub>2</sub>/N<sub>2</sub> = 3:1 to the inert-free Linde Ammonia Concept (LAC™) which utilises the Haber Bosch process to generate ammonia.

Ammonia is used widely within the chemical industry and the fertilizer industry is a major consumer of ammonia. The fertilizer industry could process green ammonia and thereby reduce greenhouse gas emissions. In the future, ammonia could

Fig. 2: Future ammonia/hydrogen energy carrier scenario

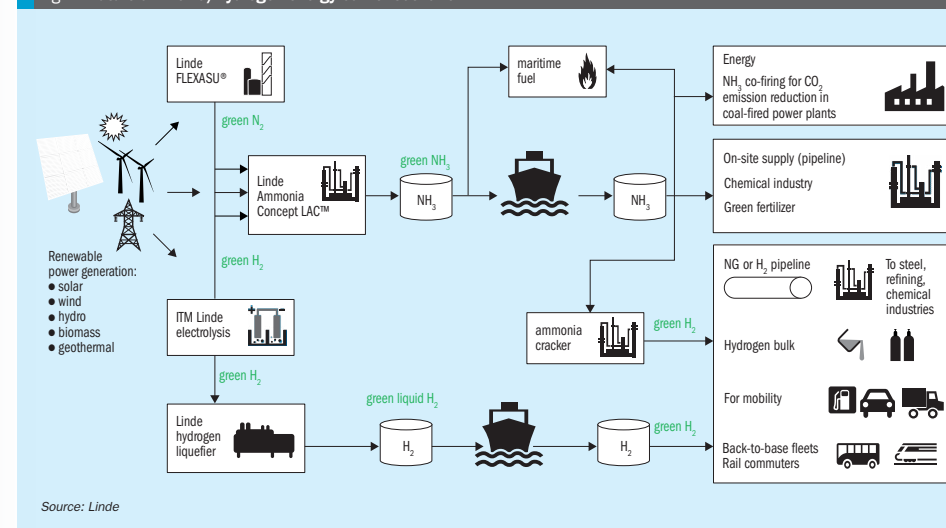

Source: Linde

be decomposed back to hydrogen in large-scale ammonia crackers, whereby the hydrogen could be used for multiple applications, as in steel refining, the chemical industry, or as fuel for the mobility sector.

A potential additional future ammonia consumer is the shipping industry where ammonia could be utilised as a zero carbon containing maritime fuel to reduce/eliminate greenhouse gas, as well as sulphur emissions. In Japan, ammonia is already used as fuel for co-firing in existing coal fired power plants to reduce greenhouse gas emissions<sup>2</sup>.

### Hydrogen generation

The green ammonia production process differs from the hydrocarbon-based route mainly due to its hydrogen production step. The electrochemical splitting of water can be accomplished by different electrolysis technologies. Today's most advanced commercially available systems from a viewpoint of technical readiness are based on alkaline electrolysis (AEL) and proton exchange membranes (PEM). Both technologies are likely to experience significant improvements with respect to capital costs and operational expenses within the next years<sup>3</sup>. Market competition will accelerate innovation and push costs further down. Of the two technologies, PEM is likely to

be the one with the greatest potential for improvements.

The main feedstock, besides electricity, is water. It needs to be completely demineralised, since the electrolyser cells are very sensitive to any contaminants. The demineralised water is continuously fed to the electrolyser water cycle as make-up for the chemical consumption. The water cycle fulfils several duties. First, it routes the water educts to the electrolysis stacks and transports the evolved product gases from the cells. Subsequently, the product gases are separated in dedicated knock-out drums for hydrogen and oxygen. Furthermore, the water flow ensures the heat removal for stack temperature control. A precise temperature control of the water cycle is necessary to keep the stacks at optimum performance. The generated raw hydrogen requires little purification effort to achieve the final product purity. Oxygen impurities are removed within a catalytic de-oxo system and excess moisture is eliminated by a dryer station.

Today's technology suppliers offer complete systems with proven design and successful track records. For instance, ITM Linde Electrolysis (ILE) electrolysis packages are characterised by the following features:

- differential pressure operation for inherent safety and raw hydrogen purity of greater than 99.99 %;

- ITM's technology with carry-over of proven design features ranging from H<sub>2</sub> refuelling station product offerings to containerised solutions for resilient industries;
- GigaStack designed and constructed for high current density operation of up to 4 A/cm<sup>2</sup>;
- GigaStack designed with vertical erection on top to achieve a compact plot space;
- scaling from 220 kW to 5,000 kW over the last ten years.

The superior dynamic behaviour and enhanced turndown ratios of the PEM technology are capabilities that are of fundamental importance for good overall efficiency in the power to ammonia conversion route. Fast response times minimise production losses. Rapid load changes, even within seconds, additionally allow for grid stabilisation services. The design challenge of electrolysis units is driven by a trade-off between efficiency, degradation rate and capital cost, since it is not easy to achieve best results in all three disciplines at the same time. A techno-economic analysis considering all project specific constraints (e.g., power profile, cost, capacity, economic parameters, etc.) helps to choose the optimal PEM electrolyser system set-up.



Fig. 3: Block flow diagram for green- and simplified HC-based ammonia production according to LAC™

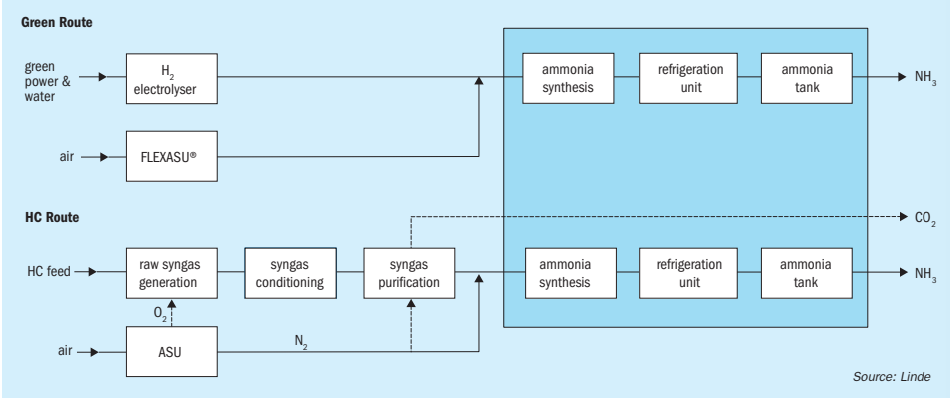

Source: Linde

## Nitrogen generation

In conventional ammonia production from hydrocarbon (HC) feedstocks the air separation unit (ASU) constantly supplies nitrogen to the process without major dynamic load changes.

Green ammonia production requires a flexible, power supply-oriented operation of the ASU. The energy-optimised operation of the ASU represents the primary objective because long-term scheduling can be adapted to the expected availability of renewable energy sources (e.g., weather forecast) and fluctuations in energy availability can be balanced at short notice by immediately regulating the operation mode of the plant. For the long-term operational planning of the ASU, a so-called demand side management (DSM) tool is applied, whereby the operation of the ASU is adapted according to the availability of renewable energy and the energy price. For this new operational requirement, the FLEXASU® has been developed by Linde.

In this regard, the plant and equipment design must consider cyclic loading due to more frequent start/stop operations required by the advanced process control system (APCS). Additional flexibility can be provided by a storage tank, as liquid product from the storage tank can be fed into the supply system to temporarily reduce the power consumption. Depending on the operating mode, nitrogen can either be recovered as liquid nitrogen (LIN) or fed back to the ASU, evaporated therein and recovered as gaseous products GAN (gaseous nitrogen)<sup>3</sup>.

## Ammonia generation

The Linde Ammonia Concept (LAC™) for a hydrocarbon feedstock consists of a state-of-the-art hydrogen plant, ASU and ammonia generation loop.

Fig. 3 shows a comparison of green ammonia production versus conventional ammonia production. The hydrocarbon-based block flow diagram is simplified for Linde's complete LAC™ product family. The "raw syngas generation" block represents a steam methane reformer or a partial oxidation unit, etc. The "syngas conditioning" illustrates any variant of CO shifting and final "syngas purification" represents CO<sub>2</sub> removal and/or hydrogen purification (e.g., Pressure Swing Adsorption (PSA), nitrogen wash unit, Rectisol®, etc.).

The hydrogen generation via the HC-based route is more elaborate due to its multiple process units and equipment involved. The electrolyser unit is distinguished as a much simpler way to generate hydrogen due to the ease of feedstock handling, simplified and less process steps.

In the case of green ammonia production, the ammonia syngas is generated by mixing hydrogen from a water electrolysis unit in combination with nitrogen from an ASU.

The main advantage of the Linde Ammonia Concept, the inert free ammonia loop design, is also adopted in the green ammonia generation concept. This design results in several benefits: First, the purge free loop design reduces the size of the synthesis loop and utilises its associated installed equipment and catalyst to their maximum

capability. Second, the necessity of purge gas cleaning and recovery is eliminated. Additionally, since less "ballast" gas is circulated, efficiency is increased leading to lower operating expenditures due to energy savings.

An optimised ammonia loop allows for an operational load range from 30 to 100% with a load change rate of 1% per minute. With additional efforts the operating load range window can be further reduced to 10%, and the load change rate increased above 1% per minute.

## Energy efficiency

Fig. 4 represents an energy flux diagram for green ammonia production with PEM electrolyser technology starting with renewable power up to liquid ammonia storage at atmospheric conditions.

From the 100% electrical energy input, approximately 61% ends up in the final ammonia product. The overall energy efficiency of the process is almost solely determined by the electrolyser. The largest energy conversion loss (waste heat) with an amount of approximately 30% occurs in the electrolyser unit. The auxiliary systems (e.g., air separation, syngas compression and ammonia refrigeration) consume only 4% of the total energy demand. Within the ammonia synthesis itself, most of the exothermicity is recovered as high-pressure steam which can subsequently be used to assist the synthesis gas compressor drive or other consumers.

The energy number for green ammonia from PEM electrolysis is approximately 8.6 Gcal<sub>el</sub>/tonne NH<sub>3</sub> (10 MWh<sub>el</sub>/tonne NH<sub>3</sub>).

Fig. 4: Energy flux diagram for green ammonia production (HHV based)

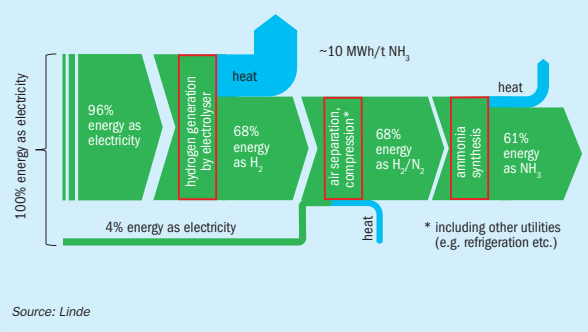

Source: Linde

## Challenges in the design of green ammonia plants

The type of renewable power and its associated reliability must be considered for the design of a green ammonia plant. Fig. 1 shows renewable electric power from hydro and biomass is characterised by a base load quality with regard to availability. In contrast, wind and solar power are distinguished by highly dynamic behaviour. The reason for these highly volatile fluctuations is shown in Fig. 5 for both energy sources. The graph in Fig. 5(a) illustrates a typical normalised wind power profile for a five-day period. The power generation is highly volatile and fluctuating between 0 and 100%. It is solely dependent on local wind conditions. In Fig. 5(b) a one-day solar power profile during winter and summer

for a "clear sky" is presented. This proves solar power generation depends on daily and seasonal fluctuations, along with the local weather conditions. From the graphs shown, it can be concluded that the design of plants operating in an island mode or having very limited access to a stabilising grid needs to be adapted to the dynamic power availability profile.

To allow for highly fluctuating power availability, all involved production steps need to be stretched to their maximum operating capabilities. Measures to cope with large dynamic demands include extended turndown ratios, maximised plant load change rates, plant robustness for frequent starts and stops, and "hot/cold" stand-by operation. Furthermore, the need for a buffer concept for nitrogen and/or hydrogen could be considered.

## Summary

In light of the required reduction of greenhouse gas emissions, the production of renewable power generation needs to be increased while fossil fuel power generation is decreased. Green ammonia and/or hydrogen are reliable chemical energy carriers which could fill this gap.

The advantages of Linde's technology for each production step towards green ammonia make the Linde Ammonia Concept (LAC™) perfectly suitable for green ammonia production applications. Linde has proven references in the design and experience in operation of conventional ammonia plants according to the Linde Ammonia Concept (LAC™). Linde can offer the design and full EPC services for green ammonia plants. The appropriate plant set-up, including a potential buffer concept, will be investigated by Linde for each project based on a detailed analysis of all project relevant parameters to deliver the most suitable and economical plant design to the customer.

## References

1. Bundesnetzagentur – SMARD.de
2. IEA, 2019, "The future of hydrogen", IEA, Paris [www.iea.org/reports/the-future-of-hydrogen](http://www.iea.org/reports/the-future-of-hydrogen)
3. Klein H., Fritsch P., Haider P., Kender R., Rößler F., Rehfeldt S., Freko P., Hoffmann R., Thomas I. and Wunderlich B.: "Flexibler Betrieb von Luftzerlegungsanlagen", Chemie Ingenieur Technik, 92: 1921-1940. <https://doi.org/10.1002/cite.202000054> (2020).
4. Schmidt O., Gambhir A., Staffell I., Hawkes A., Nelson J., S. Few S.: "Future cost and performance of water electrolysis: An expert elicitation study, International Journal of Hydrogen Energy", 42: 30470-30492 (2017).

Fig. 5(a): Typical 5-day normalised wind power load curve

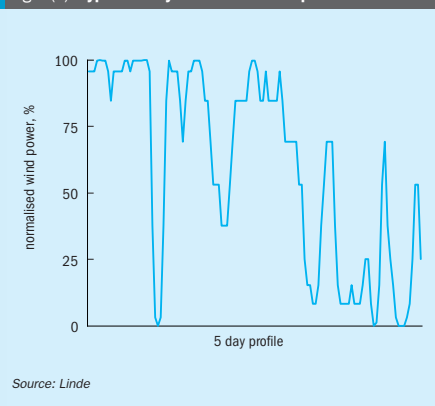

Source: Linde

Fig. 5(b): 1-day normalised solar power load curve

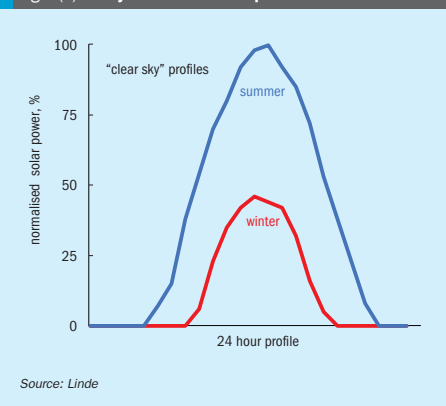

Source: Linde



Example of a small-scale green ammonia plant from thyssenkrupp Industrial Solutions (about 50 t/d). Left: utility units; Centre: ammonia synthesis; Right: hall for electrolysis cells.

## THYSSENKRUPP INDUSTRIAL SOLUTIONS

### Green ammonia: Improvements in plant modularisation

Current production routes of ammonia are solely based on the use of fossil fuel feedstocks. This implies, that greenhouse gases in the form of carbon dioxide are emitted from these production facilities. Decarbonisation of the ammonia industry is one vision for the future to drastically reduce the amount of man-made emissions, which are contributing to climate change. One solution is to go for green ammonia, which is synthesised from nitrogen from air separation and from hydrogen obtained from the electrolysis of water powered by renewable energy sources.

Green ammonia plants will typically be installed in locations where the harvesting of renewable energy takes place. These are places where intensive solar radiation, strong and steady wind, enduring water flows or a combination of the three can be found. Unfortunately, the existing infrastructure in some, or most, but not all remote locations is very limited, or even not present, which makes erection of a green ammonia plant a time consuming and costly exercise. One way to overcome this challenge is to shift construction activities away from the original site into fabrication shops or yards. This strategy will offer the following advantages:

- reduced construction time on the final site;
- reduction of risks associated with the construction phase



Module structure of a small-scale green ammonia plant from thyssenkrupp Industrial Solutions. Centre: ammonia synthesis; Right: pressurised ammonia storage tank.

- less personnel required at site during the construction phase;
- shorter commissioning phase due to pre-cleaned equipment/piping within the modules;
- fabrication of the modules in the best cost countries possible;
- improved quality of the modules due to optimal use of tools in the workshops;
- transportation limits will be overcome with adequate module sizing;
- modularisation offers the possibility to take further advantages of serial production.

Standard sizes for the green ammonia plants have been established at thyssenkrupp Industrial Solutions, for small-scale, mid-scale, large-scale and world-scale applications. For the different capacities, detailed engineering studies have been carried out and 3D models of the plants have been created. A high degree of

modularisation and pre-fabrication was aimed for in the layout to optimise the installation process. The module size for the small-scale plant corresponds to a 40-ft standard container that can be shipped over a large distance but can also be transported by truck via ordinary roads to its final destination. The pipe racks connecting the individual plant sections are also designed entirely as modules. Almost the entire Haber-Bosch synthesis gas loop can also be completely accommodated in a reasonable number of modules. This also applies to many units related to offsites and utilities, such as the complete desalination or instrument air system. Other plant components are less suitable for modularisation due to their dimensions or weight, such as the site fabricated tanks or the flare stack. The fact that the modules can also be placed on top of each other additionally reduces the plot space required for the plant. ■

## TOYO ENGINEERING CORPORATION

### TOYO green methanol for a carbon recycle society

Toyo Engineering Corporation (TOYO), a global leading engineering contractor, has established a carbon recycling strategy based on its own technology or collaboration with partners. g-Methanol® (green methanol technology) is one of the solutions offered by TOYO for CO<sub>2</sub> utilisation. TOYO has extensive experience as a licensor of the methanol process derived from fossil fuel feedstocks. Based on this experience, TOYO has established a new concept, g-Methanol®, which is derived from green H<sub>2</sub> and CO<sub>2</sub> to meet today's sustainability challenges.

Carbon capture utilisation and storage (CCUS) is an important CO<sub>2</sub> emissions reduction technology. A key feature of CCUS is carbon recycling, utilising the CO<sub>2</sub> as a resource to create valuable products and to realise a carbon neutral society. Fuel production from captured CO<sub>2</sub>, so-called e-fuel, is expected to be a promising route to consume large amounts of CO<sub>2</sub>. Although methanol is also categorised as an e-fuel, its applications extend much further as it is also a raw material for olefin production and other chemicals.

#### TOYO's carbon recycle strategy

Reducing CO<sub>2</sub> emissions to prevent global warming is a common goal for all humankind. With the ambition to achieve a carbon-neutral society, TOYO is working to provide a wide range of solutions, including technology and business development support, ranging from the capture of CO<sub>2</sub>, to the utilisation and storage of CO<sub>2</sub> (CCUS), through collaboration with partners with advanced technologies and through TOYO's expertise established in the plant engineering business (Fig. 1).

#### CO<sub>2</sub> utilisation and storage technology

TOYO's solutions for CO<sub>2</sub> utilisation and storage technology include:

- e-fuel (g-Methanol® and sustainable aviation fuel)
- CO<sub>2</sub> EOR

#### Future outlook of methanol market

The demand for environmentally friendly fuels and derivatives such as olefins is expected to drive future methanol demand.

Fig. 1: TOYO CCUS Solution

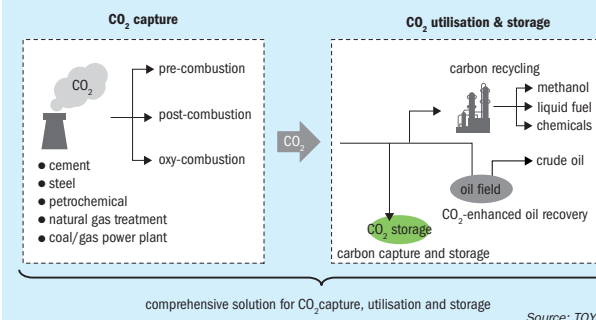
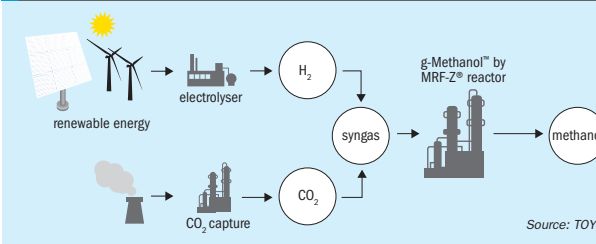

Fig. 2: g-Methanol® concept



#### Methanol-to-olefins (MTO)

MTO is olefin production technology from methanol. In Japan, the GI (Green Innovation) Fund was established by METI (Ministry of Economy, Trade and Industry) to achieve carbon neutrality by 2050. Alcohol to olefins has been recognised as one of the R&D themes to retrofit production systems<sup>1</sup>, whereby part of the olefins are produced from alcohol derived from green H<sub>2</sub> and CO<sub>2</sub> instead of fossil fuel pyrolysis. Methanol has the potential to play a key part in the production of olefins.

#### Drop-in fuel

Methanol is used as a marine fuel, an alternative to gasoline, as well as a gasoline fuel blend for automobiles. Methanol as a marine fuel and ship fuel is already a proven technology. MAN Energy Solutions has developed methanol engine technology

for ships and some tankers are already operating commercially in the world. In 2020, A consortium including Maersk, the world's largest container line, announced plans to develop an industrial-scale production facility to produce renewable marine methanol<sup>2</sup>. DME (dimethyl ether) is also produced from methanol. DME has the possibility to be used as an alternative to LPG (liquid propane gas) and diesel fuel. TOYO has developed indirect DME production technologies by adding the DME synthesis process to the methanol plant.

#### g-Methanol®

TOYO has a long history in methanol production and has now developed a new concept called g-Methanol®, a methanol production process with feedstocks that combine H<sub>2</sub> derived from renewable energy with CO<sub>2</sub> from exhaust sources, biomass and air (Fig. 2).

## CONTENTS

What's in issue 374

## COVER FEATURE 1

The slowing MTO boom

## COVER FEATURE 2

Barriers to trade

## COVER FEATURE 3

Green technologies

## COVER FEATURE 4

Wastewater treatment

NITROGEN+SYNGAS  
ISSUE 374  
NOVEMBER-DECEMBER 2022

BCInsight

Southbank House, Black Prince Road  
London SE1 7SJ, England  
Tel: +44 (0)20 7793 2567  
Fax: +44 (0)20 7793 2577  
Web: www.bcinsight.com  
www.bcinsightsearch.com



Fig. 3: g-Methanol® process flow scheme

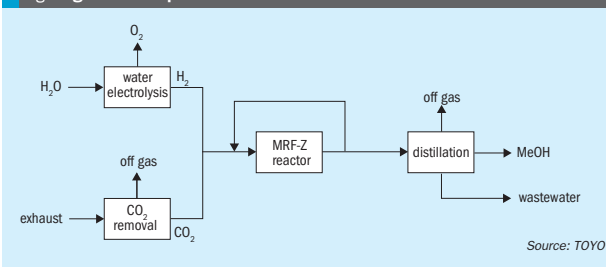

### Direct CO<sub>2</sub> to methanol synthesis

There are some important differences for the direct CO<sub>2</sub> to methanol synthesis process compared to the conventional process.

In the conventional process it is important to remove the reaction heat from reactions (1) and (2) below. The reaction heat from the direct CO<sub>2</sub> to methanol synthesis (2) is lower than that from synthesis gas (1) and (2), however effective heat removal is still required for optimal operation.

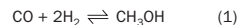

$$\Delta H = -90.77 \text{ kJ/mol}$$

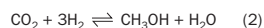

$$\Delta H = -49.16 \text{ kJ/mol}$$

A Cu/ZnO/Al<sub>2</sub>O<sub>3</sub>-based catalyst is utilised for low-pressure methanol synthesis in conventional plants. However, water produced during methanol synthesis from a

CO<sub>2</sub>-rich feed can accelerate the crystallisation of Cu/ZnO/Al<sub>2</sub>O<sub>3</sub> leading to deactivation of the catalyst.

### g-Methanol® process flow scheme

Carbon dioxide and hydrogen from battery limits are pressurised to required pressure for methanol synthesis. The mixture of recirculated gas and fresh make-up gas is preheated and introduced to the methanol reactor (MRF-Z® reactor). In the reactor, the methanol synthesis reaction, which is exothermic, takes place at low temperature over a methanol synthesis catalyst. The reaction heat is recovered by boiler water. The reacted gas containing methanol leaves the methanol reactor. After cooling by feed gas and cooling medium, methanol and water are condensed and separated at the knockout drum. Non condensed gas is recycled to the methanol reactor. Methanol and water are sent to the distillation column, and methanol is produced at top of the second distillation column (Fig. 3).

Fig. 4: MRF-Z® tube arrangement

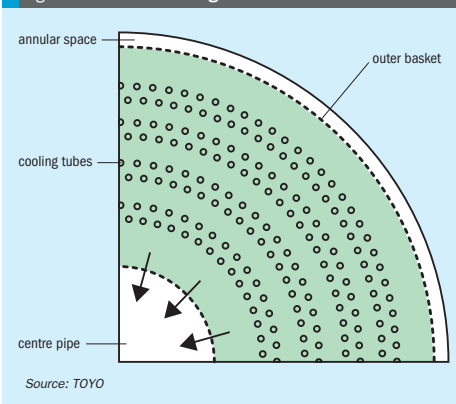

### TOYO technology solutions

TOYO's technology solutions for the direct CO<sub>2</sub> to methanol synthesis process are summarised below.

**MRF-Z® reactor:** TOYO's proprietary methanol synthesis reactor minimises the catalyst volume by using multi-stage indirect cooling. Although the reaction heat is lower than in the conventional process, suitable heat removal is still key to produce methanol from CO<sub>2</sub> with minimum catalyst volume. Thanks to multi-stage indirect cooling, the temperature profile in the catalyst bed is optimised by a suitable cooling tube arrangement using a proprietary simulator developed by TOYO. The optimised temperature profile results in the maximum reaction rate in all areas of the catalyst bed to realise methanol production with minimum catalyst volume (Figs 4 and 5).

**Easy catalyst loading and unloading:** With a shorter catalyst life compared to the conventional process, easy catalyst replacement is necessary. The features of the MRF-Z® reactor (Figs 6 and 7), shell-side catalyst loading and bayonet boiler tubes and TOYO's proprietary mechanical design, provide for easy maintenance.

Other features include:

- shell-side catalyst/wide range single train capacity;
- steam raising methanol reactor/best use of surplus heat;
- cross flow to cooling tubes/maximum heat transfer;
- radial gas flow/low pressure drop;
- bayonet boiler tubes/no thermal stress.

Fig. 5: Temperature profile

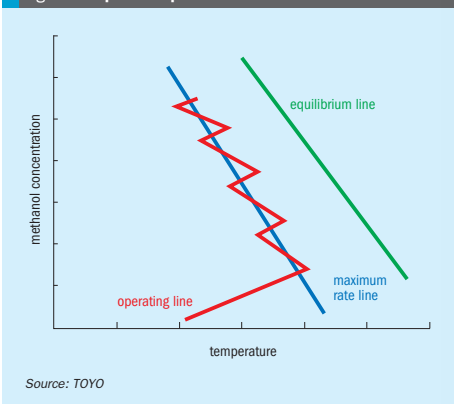
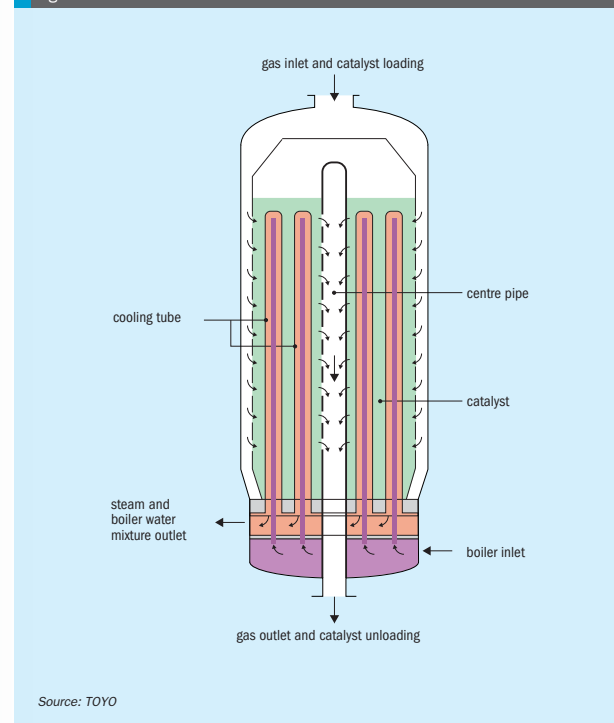

Fig. 6: MRF-Z® reactor



New developments of the methanol synthesis catalyst are an important part of the CO<sub>2</sub> to methanol process. The main goals for the catalyst are to have higher activity and a longer lifetime because of the lower equilibrium conversion at the same pressure and temperature conditions and due to the deactivation of Cu/ZnO/Al<sub>2</sub>O<sub>3</sub> catalyst from water.<sup>3</sup>

The development of methanol synthesis catalysts using CO<sub>2</sub> as a raw material has been actively carried out by many research institutes since around 1990.<sup>3</sup> The basis of the development was Cu/ZnO/Al<sub>2</sub>O<sub>3</sub> used as a conventional methanol synthesis catalyst, which improves the reaction activity at low temperatures and at the same time improves the durability of the catalyst against water produced as a by-product during the reaction. The catalyst has been studied with the goal to increase the activity and lifetime of the catalyst. In addition, research on methanol synthesis catalysts using metal catalysts other than copper-

based catalysts is also being conducted. Recently, major catalyst suppliers have released methanol synthesis catalysts for CO<sub>2</sub> to methanol.

### Activity in Japan

The world's first CO<sub>2</sub> to methanol plant has already been commercialised byCRI (Carbon Recycling International) in Iceland. In addition, Liquid Wind has announced its plans to build an e-methanol plant in Sweden. In Japan, a pilot scale project was started in 2008. The following projects are either completed or scheduled:

### MCI CO<sub>2</sub>-to-methanol project

MCI (Mitsui Chemicals) took part in the CCU project led by the Research Institute of Innovative Technology for the Earth (RITE), commissioned by NEDO (New Energy and Industrial Technology Development Organization), and developed a high activity catalyst. Refinement of this highly



Fig. 7: MRF-Z® reactor for Oman Methanol Company.

active catalyst has been tested in a pilot plant using CCU technology at MCI Osaka Works in 2009.<sup>4</sup>

### Research into effective recycling of CO<sub>2</sub>

A research project supported by NEDO<sup>5</sup> is scheduled to look into the effective recycling of CO<sub>2</sub> by converting it into core materials such as methanol at CO<sub>2</sub> storage points in the city of Tomakomai in Hokkaido, Japan. CO<sub>2</sub> captured from the refinery will be utilised as a raw material for the production of methanol. In this study, the following will be evaluated:

- basic design considering the interaction of the entire plant;
- evaluation of each component equipment;
- economic feasibility evaluation;
- examination of related technology.

### MGC circular carbon methanol

MGC (Mitsubishi Gas Chemical) has announced plans to launch methanol production using CO<sub>2</sub> and H<sub>2</sub> at the Niigata plant pilot facility (CO<sub>2</sub> throughput: approximately 1.5 t/d).

### References

1. [www.meti.go.jp/shingikai/sankoshin/green\\_innovation/energy\\_structure/pdf/006\\_05\\_00.pdf](http://www.meti.go.jp/shingikai/sankoshin/green_innovation/energy_structure/pdf/006_05_00.pdf)
2. [www.methanex.com/sites/default/files/methanex\\_brochure\\_marinefuel\\_final\\_032521.pdf](http://www.methanex.com/sites/default/files/methanex_brochure_marinefuel_final_032521.pdf)
3. Journal of the Japan Institute of Energy, Vol.74, No.3
4. <https://jp.mitsuichemicals.com/en/sustainability/rc/environment/ghg.htm>
5. [www.nedo.go.jp/koubo/EV3\\_100197.html](http://www.nedo.go.jp/koubo/EV3_100197.html)
6. [www.mgc.co.jp/eng/corporate/news/files/210330e.pdf](http://www.mgc.co.jp/eng/corporate/news/files/210330e.pdf)

[www.nitrogenandsyngas.com](http://www.nitrogenandsyngas.com)

What's in issue 374

The slowing MTO boom

Barriers to trade

Green technologies

Wastewater treatment

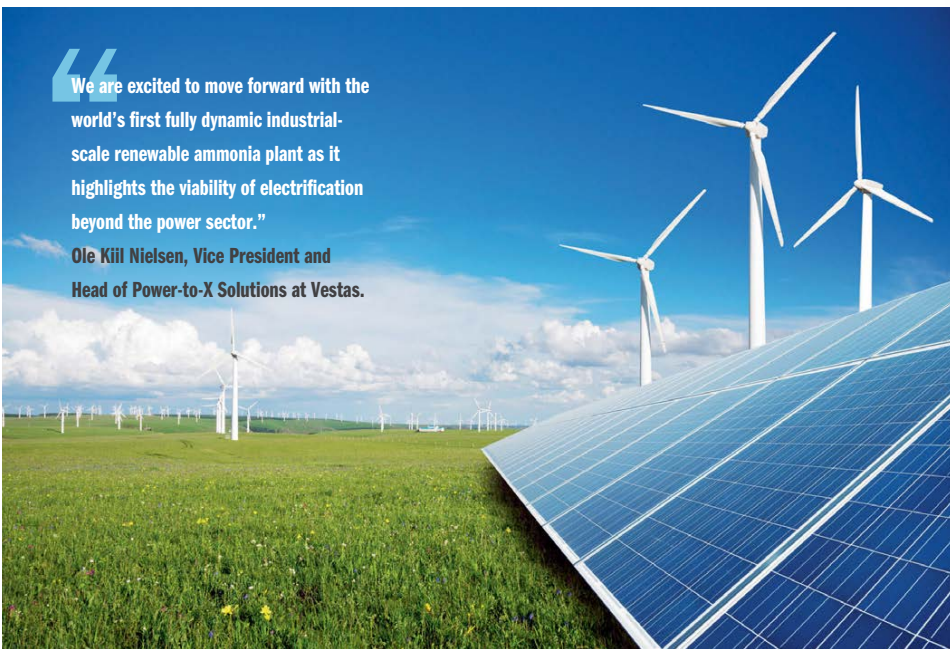

“We are excited to move forward with the world’s first fully dynamic industrial-scale renewable ammonia plant as it highlights the viability of electrification beyond the power sector.”

Ole Kiil Nielsen, Vice President and Head of Power-to-X Solutions at Vestas.

SKOVGAARD INVEST, VESTAS AND HALDOR TOPSOE

## World’s first industrial dynamic green ammonia demonstration plant

Green ammonia, produced from renewable energy, is an excellent fuel and fertilizer that can potentially replace significant volumes of fossil fuels and help accelerate the transition to a world powered by renewable energy. The cost of green ammonia is currently significantly higher than that of comparable ammonia from fossil fuel so to improve the business case and increase the attractiveness of green ammonia as a substitute for fossil fuels, a partnership of industry leaders is building the first-of-its-kind green ammonia plant at the commercial scale of 10 MW power, based on a dynamic, scalable, and cost-optimised solution. Clean power from wind turbines and solar panels will be connected directly to the electrolysis unit, making it more cost-effective than involving a battery or hydrogen storage. The plant will be located in Western Jutland, Denmark, and will produce more than 5,000 tonnes of green ammonia from renewable power each year. This produc-

tion will prevent 8,200 tonnes of CO<sub>2</sub> from being emitted into the atmosphere every year. The plant is expected to be operational by 2023.

The project has been developed by Skovgaard Invest, supported by Vestas, a global leader in sustainable energy solutions, and Haldor Topsoe, a global leader in catalysts, technology, and services for the chemical and refining industries. The partnership will jointly invest in the project. In addition, the Danish Energy Technology Development and Demonstration Program (EUDP) has awarded funding for the green ammonia project of 81 million DKK (app. €11 billion).

The parties will design the plant’s dynamic ammonia technology to secure optimal production and adapt to the inherent fluctuations in power output from wind turbines and solar panels. The ammonia plant will interface to a green hydrogen solution, integrating electrolysis with wind and solar in one smart control system. In

addition, the renewable energy generation will be connected directly to the national grid so surplus power can be sold to the grid.

12 MW existing V80-2.0 MW Vestas wind turbines and 50 MW new solar panels will power an electrolyser unit that will produce hydrogen which will subsequently be processed into ammonia. Such processes are commonly referred to as “Power-to-X”. Green ammonia has huge potential in the global effort to substitute fossil fuels with sustainable alternatives. It has been highlighted as a superior green fuel for international shipping that currently accounts for around 2% of global energy-related CO<sub>2</sub> emissions.

When in operation, this lighthouse project will deliver proof of concept and experience that can pave the way for larger Power-to-X projects in the future. The project has been specifically designed to provide the necessary know-how and operational experience to upscale the dynamic ammonia plant in new projects. ■

STAMICARBON

## A leap forward for industry sustainability

The world’s transition towards a carbon neutral society also involves the fertilizer industry, where conventional production processes must be redefined to reduce their environmental impact. Maire Tecnimont Group launched its sustainability strategy in early June this year, inspired by the United Nations Sustainable Development Goals, developed through a concept of innovation that is technological, economic, and social. Maire Tecnimont intends to position itself as an enabler of the energy transition worldwide, focusing on people and their well-being and the communities of the geographies in which the Group operates.

From this perspective, Stamicarbon, the Group’s innovation and licensing company, is determined to be part of the change with innovation and investment in sustainable, carbon-free fertilizer production. Its recently introduced Stami Green Ammonia technology package makes it possible to produce ammonia from renewable energy sources. The resulting green ammonia can then be used to produce green nitrate-based fertilizers.

### How green ammonia is produced

The most common industrial way to produce ammonia is the Haber-Bosch process, which

uses nitrogen from the air and derives hydrogen from hydrocarbons, most commonly natural gas, through a conversion process of steam reforming (Fig. 1).

Since fossil fuels are used as feedstock for ammonia production in the first step of the process, carbon monoxide is produced alongside hydrogen. While hydrogen continues further into the synthesis, carbon dioxide, having no other role, is mainly released into the atmosphere. The output of this production process is known as “grey” ammonia.

Green ammonia technology offers a more sustainable alternative by eliminating carbon from the process. In it, water electrolysis is used to derive hydrogen, nitrogen is added from the air, and the rest of the production process is powered by renewable energy sources. Using electricity, water is separated into hydrogen and oxygen, no fossil fuels involved, while electricity is derived from renewable sources like solar, wind, water, and geothermal energy (Fig. 2).

In short, with Stamicarbon’s green ammonia technology package, ammonia can be produced with nature’s elements like sun, air and water, resulting in a sustainable, carbon-free output. Of course, since the plant operates on renewables,

it needs a constant supply of energy, so the location needs to be considered carefully – it is best to build a green ammonia plant near the energy source to optimise the financial model. But it is also possible to obtain electricity by connecting the plant to a green energy grid or hydropower, while carbon-free nuclear power could also be considered.

### Technology features of Stami Green Ammonia

A Stami Green Ammonia plant uses renewable energy sources to power ammonia synthesis instead of fossil fuels, offering a viable solution for tackling the global carbon challenge. The technology configuration, characterised by a modularised approach and thus perfect for small-scale facilities, is the first of its kind, based on proven technology.

The technology package is available in proven design capacities for small-scale plants – 100 t/d, 200 and 250 t/d of ammonia production – but can be scaled upwards. A Stami Green Ammonia plant has a lean and compact design, with a footprint of approximately 15 x 30 m, including the compressor building, and

Fig. 1: “Grey” ammonia production process

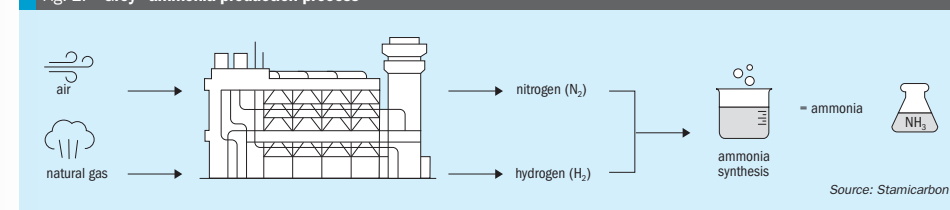
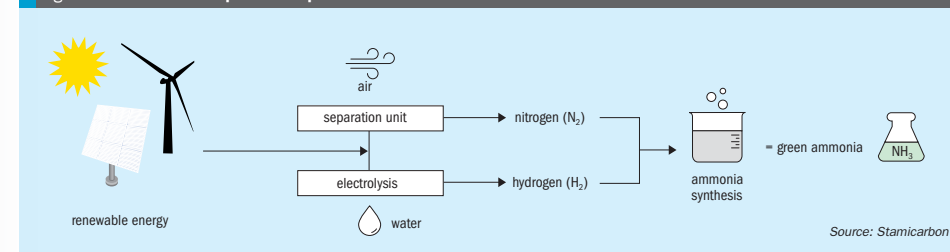

Fig. 2: “Green” ammonia production process



CONTENTS

What’s in issue 374

COVER FEATURE 1

The slowing MTO boom

COVER FEATURE 2

Barriers to trade

COVER FEATURE 3

Green technologies

COVER FEATURE 4

Wastewater treatment

NITROGEN+SYNGAS  
ISSUE 374  
NOVEMBER-DECEMBER 2022

BCInsight

Southbank House, Black Prince Road  
London SE1 7SJ, England

Tel: +44 (0)20 7793 2567

Fax: +44 (0)20 7793 2577

Web: www.bcinsight.com  
www.bcinsightsearch.com



Fig. 3: 3D model of a Stami Green Ammonia plant

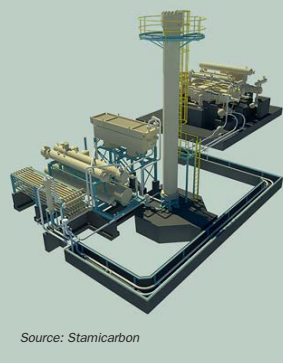

Source: Stamicarbon

uses about 35-100 MW of power, depending on capacity (Fig. 3).

Recent technological developments in the fertilizer industry have focused more on economy of scale and fertilizer production of higher outputs. However, now that the industry is moving towards greener technologies, the availability of renewable electricity, limitations in electrolyser production capacity and lack of economy of scale thereof must be considered, and these are not yet sufficient to facilitate large-scale projects at short notice. Secondly, existing technology is not yet ready to efficiently manage the intermittency of renewable feedstock required for standalone large-scale green ammonia production.

Stami Green Ammonia has four recently commissioned operating technology references based on natural gas. This is the strongest technology reference in a small-scale range that makes a sound basis for further development of the future small-scale ammonia plant concept.

The technology includes the following key features:

- high capex efficiency;
- strongest reference base with four small-scale plants in operation;
- lean, compact and modularised design;
- high plant reliability with a proven track record;
- compliance with highest environmental standards.

The main technological feature of Stami Green Ammonia is the use of a high-pressure ammonia synloop (approximately 300

bar), which has been customised to make the most efficient plant design at a small scale and with green feedstock. This design choice allows ammonia to be condensed with the cooling water, eliminating the need for a refrigerating compressor. As a result, the plant operates with a single proven and reliable electric-driven reciprocating multiservice compressor. The minimal equipment needed for plant operations leads to substantial capex saving, which is an important consideration for small-scale applications.

The technology package offers a competitive solution for local production on a small scale and can be applied in combination with Stamicarbon's existing (mono-pressure and dual-pressure) nitric acid and urea technologies, moving from grey ammonia to green ammonia-based fertilizers to produce green nitrate fertilizers. In combination with the use of recycled or recovered CO<sub>2</sub>, it reduces the carbon intensity of urea fertilizer production. Stamicarbon is also ready to apply its green ammonia technology to other industries, such as steelmaking, to help make them more sustainable.

### Renewable power-to-fertilizer project in Kenya

The first commercial application of Stami Green Ammonia will take place at the Oserian Two Lakes Industrial Park in Kenya, a 150-hectare sustainable devel-

opment project in Nakuru County, 100 km from the capital Nairobi. Stamicarbon will contribute both its green ammonia and its nitric acid technologies to the renewable power-to-fertilizer plant project, working alongside Maire Tecnimont Group's subsidiaries MET Development (the Project Development Company) and NextChem (the company for the development of technologies for green chemistry and energy transition), to build the world's first commercial nitrate fertilizer plant operating at an industrial scale (approx. 200 kt/a) powered by renewable sources of energy.

The plant will be powered primarily by geothermal and solar energy, using about 70 MW of renewable power, which will allow for a yearly reduction of 100,000 t of CO<sub>2</sub>, compared to a fertilizer plant powered by natural gas. Preliminary engineering works have already begun, and NextChem plans to start the front-end engineering design (FEED) by the end of 2021. The objective is to start commercial operation of the plant in 2025, producing 550 t/d of calcium ammonium nitrate (CAN) and fertilizers based on nitrogen, phosphorus, and potassium (NPK) to meet the demand of local agricultural requirements. The green power-to-fertilizer plant at the Oserian Two Lakes Industrial Park will become the first of its kind and support local fertilizer production in Kenya, securing the availability of fertilizers at the right time in the agricultural season.

Fig. 4: Stami Green Ammonia technology

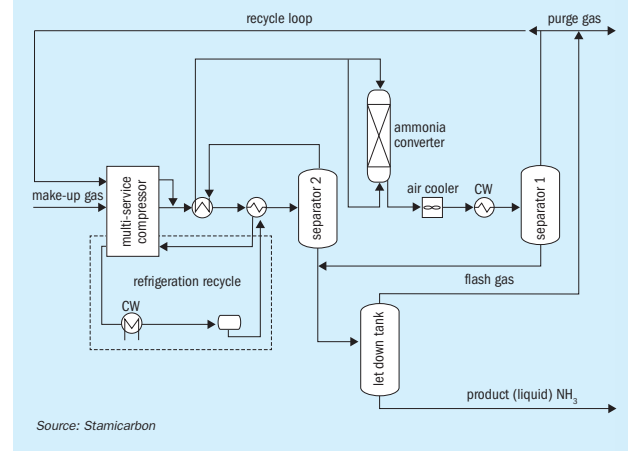

Source: Stamicarbon

### The second commercial application of Stami Green Ammonia

In September 2021, Stamicarbon, NextChem and MET Development signed an agreement with Greenfield Nitrogen LLC to develop the first dedicated green ammonia plant in the US Midwest. The 240 t/d plant will be based on Stami Green Ammonia technology provided by Stamicarbon (Fig. 4), while NextChem will start a feasibility study, and MET Development will assist with project development. This is already the second commercial Stami Green Ammonia plant under development since the technology entered the market in May 2021.

The new plant, to be located near Garner, Iowa, will be the first of Greenfield Nitrogen's green ammonia facilities in the US Corn Belt, the region in the Midwest widely known for its production of corn. This new plant will be powered by renewable energy resources and will produce around 83,000 t/a of ammonia, reducing the region's dependency on imported ammonia. It will also contribute to reducing CO<sub>2</sub> emissions by the industry, expected to save over 166,000 t/a of CO<sub>2</sub> emissions.

### Green ammonia for European green initiatives

Besides the direct development and licensing of new commercial green ammonia plants, Stamicarbon is also participating in two European green initiatives to make the industry more sustainable.

The first one is an EU-funded project INITIATE (Innovative industrial transformation of the steel and chemical industries of Europe) to use the carbon-rich off-gases from steel mills as feedstock for urea production. At the core of this process is a modular carbon capture utilisation and storage (CCUS) technology, which allows for integrating the conditioning of steel gases with ammonia synthesis. Stamicarbon will be responsible for the commercial implementation plan and supply its green ammonia technology to justify the pilot project's viability and prove the capability to produce ammonia to build a reference plant for urea production in the next stage. In addition, it will supply the ammonia technology license and ammonia converter for the 3 t/d pilot plant in Luleå, Sweden.

The second initiative is Stamicarbon's application of its green ammonia technology to PROMETEO, a European Horizon 2020 project with the aim to develop an innovative prototype for high-temperature electrolysis, using renewable energy to power the continuous production of green hydrogen. The innovative solution will address intermittency in the solar power supply by managing energy conversion and re-generation phases. Green hydrogen produced in this way will contribute to the production of green ammonia and green fertilizers.

### Future-proof ammonia production

The world is demanding accelerated cooperative climate action to reduce emissions. At the same time, feeding the ever-growing population remains a challenge. Stami Green Ammonia aims to serve as a gateway to carbon-free and future-proof green ammonia production, representing a significant leap for sustainability within the fertilizer industry, while also offering exciting opportunities for collaboration between the fertilizer and energy markets.

# BORSIG



➤ WASTE HEAT RECOVERY SYSTEMS

➤ WASTE HEAT BOILERS FOR AMMONIA PLANTS

➤ SYNLOOP WASTE HEAT BOILERS FOR AMMONIA PLANTS

➤ SYNTHESIS GAS COOLERS DOWNSTREAM OF PARTIAL OXIDATION OF OIL OR NATURAL GAS

[www.borsig.de/pro](http://www.borsig.de/pro)

BORSIG Process Heat Exchanger GmbH

Phone: +49 (0)30 4301-01

Fax: +49 (0)30 4301-2447

E-mail: [info@pro.borsig.de](mailto:info@pro.borsig.de)

Egellsstrasse 21, 13507 Berlin

Germany



CONTENTS

What's in issue 374

COVER FEATURE 1

The slowing MTO boom

COVER FEATURE 2

Barriers to trade

COVER FEATURE 3

Green technologies

COVER FEATURE 4

Wastewater treatment

NITROGEN+SYNGAS  
**ISSUE 374**  
NOVEMBER-DECEMBER 2022

**BCInsight**

Southbank House, Black Prince Road  
London SE1 7SJ, England

Tel: +44 (0)20 7793 2567

Fax: +44 (0)20 7793 2577

Web: [www.bcinsight.com](http://www.bcinsight.com)

[www.bcinsightsearch.com](http://www.bcinsightsearch.com)



The Scanfeld system is more than just a gas camera.

# On the lookout for gas leaks

Scanfeld™ is the world's first remote sensing solution for fully automated early-warning gas leak detection for chemical plants. Using FTIR spectroscopy, Scanfeld™ identifies hundreds of different gases in real time from kilometres away. With just a few Scanfeld™ sensor units, large production sites, tank farms, or gas loading areas can be monitored reliably. Gas leaks are quickly detected, and the formation of dangerous gas clouds is monitored, measured, and visualised. René Braun of Grandperspective discusses how the system works and how it is being applied in industry.

Industrial-scale chemical processes continue to expand year on year, and the volume of hazardous gases handled by these processes has equally grown, especially in the last ten years. One of the key bulk chemicals that requires tight monitoring is ammonia, and there has never been a more important time to monitor ammonia emissions than today.

The need for more efficient monitoring of ammonia, and other similar hazardous gases, has become paramount for a number of reasons. On the one hand, the global production of nitrogenous fertilizers continues to grow every year. These fertilizers use ammonia as the base material and are responsible for a production output of over

200 million t/a. On the other hand, the development of compact production sites, longer turnaround times, and fewer staff to man these plants are different factors that are enabling more emissions to be released into the surrounding environment, exacerbating any potential hazard risk.

Luckily, there are now solutions available, such as the Scanfeld™ monitoring system, that can help to monitor the emission of toxic gases. High-level monitoring is going to be paramount in the coming years for ammonia because new markets are starting to emerge, including using ammonia for fuel and in hydrogen storage, which will increase the demand and production of ammonia globally.

## A concern to public health

Industrial sites are looking to be more carbon efficient and lower their carbon output (with the aim of having zero carbon emissions) and are regularly monitoring the output of gases into the local environment. This has become a more pressing matter in recent years because of the expansion of urban areas, as well as an increase in population densities, that are putting more and more people within reach of chemical sites that emit hazardous gases in sufficient quantities for it to be recognised as a health concern.

Despite there being more concerns due to urban sprawl, a study published by the UK Health and Safety Executive (HSE) showed

that around 30% of all major leaks go unnoticed and are silently contributing to health issues, physical damage, and even fatalities. In 2019 alone, billions of euros of damage were caused by undetected gas leaks, and in China alone, there were more than 800 undetected leaks and 400 fatalities. If you then look at the bigger picture across the whole world, then you start to understand the need for more efficient chemical monitoring operations in industrial-scale plants.

## The challenges of remote chemical monitoring

Detecting gas leaks has always been a challenge, especially in industrial settings, and it's no different today. It's just that the dynamics have changed, and different technological options are now available to us. In years gone by, canary birds were used as a warning system to alert miners to high levels of carbon monoxide levels in deep coal mines. Since then, sulphur sticks have been used to detect ammonia leaks in refrigeration units, and the modern-day equivalent of early warning gas leak detectors is gas sensors that can report on minute levels of hazardous gas in a target area.

Gas sensors are a suitable option for many small-scale setups, but when it comes to industrial-sized plants, it's a different scenario altogether. Setting up a system that can survey a large area, i.e., over a whole chemical plant, is the only viable solution for monitoring the industrial sites that are near populated areas. Having early warning systems in place is also key for any monitoring system, as the ability to detect hazardous gas clouds early not only protects the local workforce, but it also helps to protect the local urban areas as well.

The common approach to detecting hazardous gases has typically been to use a gas detector which provides a gas concentration as their output. Many gas detectors in use today are only single point detectors, meaning that they only analyse a single location of interest, so they can create a false sense of security as they don't construct the entire emission picture across the entire plant. This means that pockets of gas can escape in areas where there is little to no analysis taking place, and these gas leaks will ultimately go undetected.

The only way to overcome this issue with single point sensors, is to place a sensor at every potential point of release. This is not only cost prohibitive, it is also a time-consuming solution, because each sensor

needs to be calibrated and maintained by qualified personnel. The data also needs to be interpreted as well (introducing more cost), and if the sensors are not perfectly positioned, then the data can often be difficult to interpret and provide little value despite the cost and time investment.

These issues become more apparent when the production and storage areas of an industrial site become larger, as more sensors and personnel are required to operate these ineffective systems. Another issue of single point systems, especially in larger sites, is that they are not well-equipped for outdoor measurements where the wind will rapidly spread any gases in the different directions, preventing detection from taking place in a timely manner.

The openness to the elements is a factor that renders a lot of monitoring systems ineffective, because while the concentration of the gas is 100% at the initial point of release, the gas cloud can propagate in all directions and dilute very quickly, leading to undervalued results for major leaks and overstated results for minor leaks. So, rather than looking at single points of measurements that are inaccurate, the future of remote chemical monitoring needs to look at the whole industrial landscape as a complete measurement, rather than as a collective of individual data points that don't give the whole picture and the true gas concentrations in the area.

## FTIR to the rescue?

While there are a lot of issues with remote chemical monitoring systems in place today, there are alternatives to these ineffective and costly systems. Optical gas imaging (OGI) systems, for example, can provide coverage over much larger areas using infrared red (IR) light, but they lack the sensitivity and specificity required to measure real-time gas leaks. Also, like other detection systems, OGI sensors can only detect a single substance in a particular area of interest, so any deviation from a 'normal situation' can lead to false readings that are interpreted to be a gas leak.

On the other hand, there is Fourier transform infrared spectroscopy (FTIR). FTIR is known for its use in routine laboratory chemical analysis, but it is also a well-established remote sensing technique and is already used by security forces to supervise large areas in case of chemical release or terrorist attacks. One of the key features of FTIR is that it is a selective tech-

nique for hundreds of chemicals, and it is extremely sensitive to ammonia and other organic compounds. The other key feature of FTIR is the ability for it to be used like a giant gas camera from miles away.

The characteristics of FTIR mean that it offers a solution to the challenges of remote chemical monitoring: it is a sensitive technique for toxic gases, and it can be used to build a much wider gas leak picture compared to other sensing systems. These FTIR monitoring systems measure gas clouds by the spectroscopic analysis of infrared radiation. The internalised temperature within every object means that all object emits IR waves, and these waves can be chemically analysed from a distance.

For monitoring gaseous substances remotely, there is one wavelength region, from 500 to 1,500 cm<sup>-1</sup>, that is most relevant when analysing the chemical composition of a gas. This is known as the fingerprint region, and it is a spectral region where many chemical species interact with the IR radiation. This leads to an interaction with the radiation, a spectral absorption or an emission feature known as the spectral fingerprint, that is unique for each chemical compound, enabling the gas to be identified.

## A modern-day solution for large chemical plants

Installing an FTIR sensing instrument is simply not enough for mapping hazardous gases over large areas of industrial-sized plants, you need something that has been designed and tailored to solve this particular problem from the ground up. This is what has been achieved by Grandperspective with its Scanfeld™ system, and it is the first FTIR remote monitoring solution to hit the market for probing suspicious spectral fingerprints within the chemical industry.

The Scanfeld system is more than just a gas camera. The Scanfeld sensors are a series of completely passive FTIR spectrometers that will continuously scan an area of interest and because they are attached to a sophisticated mechanical positioning system, the system allows for both imaging motion and 360° coverage of multiple scan areas. Each scanning point (a very narrow cone known as a Toxel) is represented by an infrared spectrum, which can then be analysed for the chemical composition of the gas and its concentration. The sensors are connected to an on-premises server which provides real-time control and





A single Scanfled™ unit can cover an entire industrial site with multiple regions of interest.

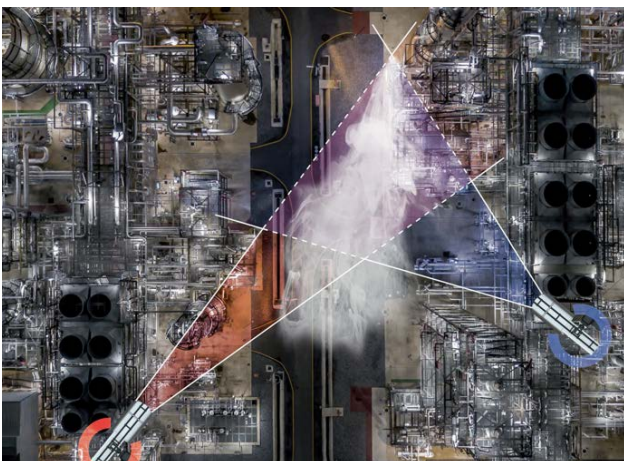

With the help of two or more sensor units the actual gas cloud distribution and concentration can be determined.

measurement evaluation. The system then provides graded alerts based on the total amount of gas in the air, the gas cloud size, and the persistency of the event.

### Key characteristics of Scanfled

There are typically four functional pillars, the four Ws, to the Scanfled system, which are where, what, how much and since when. This essentially means, that for over 400 chemical compounds, the Scanfled system can tell you where the gas leak is, what gas has leaked out, how much of it there is, and when the event started. One of the defining

features of the system is that only a single installation is required (so long as it is a tall spot) to scan multiple areas up to 4 km away from the sensing unit.

Compared to other remote sensing systems, Scanfled has superior monitoring capabilities that extend beyond long-view sensing and a high specificity. Scanfled has also been specially designed to be suitable for outside environments, and the propagation of a gas can not only be tracked over several square kilometres, but the local weather does not affect the capabilities of the measurement, including adverse weather conditions such as rainfall, fog, and low light.

The low light capabilities also means that Scanfled can monitor in real-time 24/7, both day and night, and the concentration distribution of any gas clouds is measured in real time (including the actual concentration of the released gas). Unlike ground sensors, Scanfled can change its field of view at any point and analyse any gas clouds at different heights.

A typical scan provides a real-time situation assessment with a timeline of events, but how quickly and how much you want to scan is completely up to you. The scan can be set up to automatically scan a pre-defined area, and the slower the scan speed the better the spatial resolution, but the faster scan speeds can cover larger areas in a single scan.

Most scans are performed within seconds and once a gas is detected the location and dimension of the gas cloud is measured. The user interface then provides an overlay image and details about the gas leak, including the leak location, the near-field propagation of the gas accumulation, and the concentration of gas in the air.

According to Peter Schmitz, HSE Manager OCI Nitrogen B.V.: "The Scanfled system makes us feel safer in a couple of ways, first of all, the operators, as they have a second pair of eyes looking at the plant from a distance. And secondly, we have an early warning not only to our emergency response system, but also to our communities nearby, and I think that's a great added value of the system."

All these characteristics enable Scanfled to improve safety in and around industrial chemical plants. The visualisation and alert system provide additional barriers to prevent the escalation of a gas leak when it has occurred, where the operator is first alerted to the leak, followed by the image visualisation of the leak so that appropriate action can be taken. While all the different characteristics of the scanning system are key to enhancing safety, it is the early warning and advanced mapping capability that set Scanfled apart in terms of being a safe choice for chemical plants.

### An effective early warning system

Time is the most crucial factor whenever there is a hazardous substance in the air, especially when it is a substance that is either toxic, flammable and/or combustible, such as ammonia. There is even more of a need for speed if these leaks are close to urban areas. If these types of leak

events are not detected early on, there can be severe consequences to the environment and surrounding population, as well as posing a risk to infrastructure (including damage, production loss, and downtime).

"Time is the key element. You have to respond within minutes. Therefore, you need to get a picture in minutes to quickly inform the responders, the community, the operators, and everyone involved. I would say the present gas monitoring systems are not able to respond in a time frame like the Scanfled system does," explains Peter Schmitz.

Knowing every exact detail of these events when they occur is crucial to containing the spread of the leaked substance, but many other methods beyond Scanfled fail to provide the detail required by first responders and firefighters who are responsible for managing gas leaks. The Scanfled system combines the capability for early warning (no matter how small the leak) with precise information

about the gas emissions and how they change over time. Once the release has stopped, the sensors also play a vital role in de-escalating the situation by confirming that the released gas has dissipated.

### Mapping toxic gas clouds

The cloud profile of leaked gases is very different if the leak is outside compared to in confined spaces. Inside, detectors can spot the rising gas levels much more easily, regardless of where the source of the leak originated from. In wide open spaces, the gas rapidly dilutes when it moves away from the release point, so tracking the source of the leak with a traditional gas sensor is a near impossible task.

Scanfled can not only perform near-field mapping for detecting the origin of gas leaks in real-time, but it can also perform wide field mapping for determining the concentration of the gas in the local area, no matter how much it has diffused and diluted. The speed of the scan is also fast enough to map the propagation of gas releases, and this is what also provides an early warning when a gas leak occurs.

"Scanfled is creating an overview. It is a totally different approach from traditional instrumentation, where you are only looking at certain points where we expect the ammonia to be. But a leak can be anywhere. You cannot be prepared for leakages in your whole plant by installing traditional sensors just everywhere. With the scanfled system on a spot with a good

overview it's like having a million traditional transmitters," said Patrick Thijssen, Lead Discipline Engineer Sitech Services B.V.

Being able to map the gas cloud dynamics across a wide area is a key factor in why Scanfled is so effective, as it allows the gas concentrations to be determined across a wide radius of the incident. This allows the appropriate measures to be put in place to mitigate the effects of the leak. These analyses can all be done without any prior knowledge regarding the location of the gas accumulation, or the wind conditions, and allows for much wider areas of a chemical plant to be monitored automatically.

Assessing the gas concentration becomes inherently more difficult as the gas spreads and the affected area becomes larger. As the wind sweeps the gas cloud in different directions, the localised concentrations can rapidly change, and this is where local gas sensors become very ineffective as they present a false interpretation of the concentration of the gas cloud and a false sense of safety in the local area. This is where the wide field mapping function showcases the value proposition of the scanfled system, as any widespread gas cloud can be continuously mapped and monitored in an ever-changing environment.

### Chemelot: Scanfled in real-world situations

Now, you might be thinking that the Scanfled monitoring system is an interesting development and solution to the modern-day chemical monitoring challenges, but can it be used in commercial settings? Has it been tried and tested? The answer to both of those questions is yes. Scanfled was recently implemented at the Chemelot industrial park in the Netherlands, because it is one of the largest chemical parks in Europe and is located in a densely populated region near Maastricht and Düsseldorf. The campus houses many chemical producers, with oil processing, hydrocarbons, ammonia, and fertilizers all being present on the site. So, in terms of safety, it's a site that could pose more risk than a lot of others.

The first phase of the pilot project centred around a melamine and urea production unit and looked to reduce the risks associated with unexpected airborne releases, with the second phase being a feasibility study about the possibility to monitor the whole north side of the industrial park. There were four stacks of OCI Nitrogen in the industrial park that needed

to be monitored for accidental ammonia release, with a focus on early warning.

Specifically, Scanfled was also employed to protect the adjacent Brightlands Campus by monitoring any significant gas releases from the chemical plants. Each of the sensors covers a km range, so despite the large size of the site, only two sensor units were required to cover the entire area.

The installation at the Chemelot site provides an early warning detection within minutes of a critical gas release and can monitor the emissions that reach the Brightlands Campus. Once a gas release is detected, the software can generate a geo-referenced representation of the cloud and track its progress. Scaling up the Scanfled monitoring system with a just few more sensor units at the Chemelot site will cover the entire north side of the campus and provide enhanced safety measures over a much wider area.

### Overall outlook

There are many options for gas monitoring. If you're looking to monitor gas leaks in a closed environment, then conventional gas sensors will be fine, but if you're looking to measure outside and over wide areas, then the Scanfled solution provides the ability to monitor hazardous gas leaks and their diffusive spread in real-time.

Scanfled is a highly automated monitoring solution that will continuously survey large areas in real-time and has been proven to be an effective tool at Chemelot, where the installation provides a very short response time to unexpected gas releases. The scanfled system operates under a minimal time-to-alert principle and provides the exact information about the what, where, when, and how much of unexpected gas emission incidents.

Overall, Scanfled offers additional protection barriers for large chemical sites while protecting the local area and population. Scanfled also provides a quicker post-incident resolution by detecting when the released gas cloud has dispersed and is no longer posing a threat. While conventional gas sensors are advantageous in inside environments, Scanfled offers a more cost-effective solution for remotely monitoring gas leaks in outside environments – with both wide and near field functionalities – because only a few installations are required to cover even large industrial parks containing multiple chemical plants. ■

## CONTENTS

### What's in issue 374

## COVER FEATURE 1

### The slowing MTO boom

## COVER FEATURE 2

### Barriers to trade

## COVER FEATURE 3

### Green technologies

## COVER FEATURE 4

### Wastewater treatment

NITROGEN+SYNGAS  
**ISSUE 374**  
NOVEMBER-DECEMBER 2022

**BCInsight**

Southbank House, Black Prince Road  
London SE1 7SJ, England

Tel: +44 (0)20 7793 2567

Fax: +44 (0)20 7793 2577

Web: www.bcinsight.com  
www.bcinsightsearch.com

# Redefining the sustainability of effluent treatment processes

Nitrogen-rich wastewaters remain a major issue for fertilizer and other industries. Saipem's new electrochemical technology, SPELL, is an important step towards the overall objective of zero industrial pollution. A complete engineering review of the technology, its alignment with all international applicable standards, and optimisation has now been concluded and the technology is ready for deployment for the removal of ammonium nitrogen from industrial waters and wastewaters. Saipem discusses the key features of SPELL and reports on the first two industrial references.

Awareness of the sustainability of processes is changing; a renewed approach and rules for environment safeguarding are maturing worldwide, while technology innovation cells fight for domination of new markets. The new energy scene emerging in the coming years will be a mosaic of many competing forces, which is quite difficult to forecast today. What is clear, however, is that the speed of innovation and the adoption of new technologies will be fundamental to push continuous improvement towards the energy transition process.

Saipem is aware that all of its activities, from the planning and design stages to construction and operation, have an impact on the environment, both directly and along its business value chain. Saipem's participation in the vision of a more sustainable future translates into the commitment to identify, assess, and manage environmental impacts tied to business management. To offer a distinguishable value proposition as system integrator, Saipem is committed to using advanced technologies, in the most efficient process schemes, and to deliver affordable management solution for specific purposes.

Growing pressure on water resources has driven Saipem to intensify its efforts on the development of new water technologies as a further improvement to its water resource management strategy. Of utmost importance are the investments in research and development programmes to create technologies that minimise the environmental impact

of operations and associated services. For instance, one success story, as a result of effort spent on innovations for wastewater management, is the development of a special electrolytic technology capable of removing nitrogenous contaminants from waters and wastewaters.

Contamination of (waste)waters with nitrogenous compounds is one area of particular concern; this is a typical challenge for many industrial and municipal plants, and nitrogenous fertilizer plants are a primary example. The contamination caused by nitrogenous compounds is associated with severe environmental impacts including eutrophication of surface waters, toxic phenomena, and decline in biodiversity. Nitrogen (as well as phosphorus) is a natural part of aquatic ecosystems; it is a nutrient supporting the growth of algae and aquatic plants, which provide food and habitats for fish, shellfish and other smaller organisms that live in water. But high concentration of nitrogen in waters causes a perilous unbalance in the ecosystem: significant increases in algae harm water quality, food resources and habitats, and decrease the oxygen that fish and other aquatic life need to survive. Algal blooms can severely reduce the oxygen in the water, leading to illnesses and even death in marine life. Some algal blooms produce elevated toxins and bacterial growth, which are also harmful to humans coming into contact with polluted water, consuming tainted fish, or drinking contaminated water.

Current technologies to treat this kind of pollution are complex, costly, and unreliable, while nitrogen-rich (waste) waters remain a major issue for fertilizer and other industries. On the other hand, regulations and environmental limits are becoming more and more severe to limit the impact of this kind of pollution, even introducing bioassay practice with special requirements.

In response to the issue of nitrogen-rich waters and wastewaters, Saipem sought to find a solution by promoting a campaign to scout for innovative technologies; particular attention was paid to novel electrochemical technologies.

Many electrochemical processes for water treatment have been developed over the years, with the aim of reducing costs compared to traditional processes; the on-site production of necessary chemicals (e.g., by electrochlorination) is a common example. Moreover, electrochemical treatments are usually very efficient and reduce process retention times, thereby allowing smaller plants. With regard to the treatment of (waste)water, electrochemical processes have various advantages over other methods. They are robust, easy to operate and flexible in case of fluctuating wastewater streams. In addition, a relatively broad spectrum of organic and inorganic impurities can be removed<sup>1</sup>.

The novelty of the electrochemical processes and their potential is widely recognised, and their specific applicability as an

emerging technique for water treatment is captured in the BAT revision of 2016<sup>2</sup>.

Fig. 1: Residual ammonia removal efficiency and power consumption

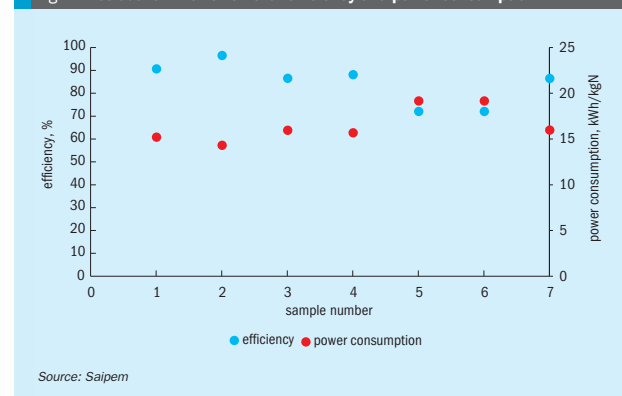

emerging technique for water treatment is captured in the BAT revision of 2016<sup>2</sup>.

Electrochemical processes are associated to material transformations forced by or generating electric current. A distinction is made between electrolysis, in which the electric current is supplied from outside, and galvanic elements, for which the electrical current is generated by the reactions among the substances contained in the water (the latter not being implemented yet in practice or on a technical scale). Reactor designs are very specific regarding the various (waste)water compositions and the intended application; the designs and modes of operation of electrochemical reactors are therefore diverse.

In 2017, following a rigorous evaluation process, Saipem established a collaboration with Purammon Ltd., a technology start-up specialising in electrolytic technologies and processes. Since then, the technology has been optimised and adapted ready for exploitation on a full industrial scale basis. A complete engineering review of the technology, its alignment with all international applicable standards, and optimisation has now been concluded and the technology is thus ready for deployment for the removal of ammonium nitrogen from industrial waters and wastewaters.

Saipem's electrolytic process, named SPELL, transforms ammonium nitrogen contaminants (i.e., ammonia and urea) into their elemental and harmless components (namely nitrogen, hydrogen, and carbon dioxide if urea is in the feedwater), according to the following reactions:

Ammonia reaction:

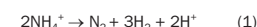

Urea reaction:

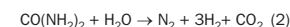

These reactions are triggered by the electric current when it is applied to the electrolytic cells. By nature of the electrolytic process itself, the promoted reactions have zero-order kinetics; the reaction rate is independent of the contaminants concentration in the feed stream, and unlike other common treatments, the removal capacity remains stable over the entire process design range.

The distinctive characteristic of SPELL is its simple one-step reaction, which is intrinsically more efficient than the conventional biological processes that are commonly used for the same objective. The electrolytic process directly oxidises the ammonia consuming only three electrons provided by the external power connection. The energy consumption is directly associated to the reaction, or rather, to the contaminants load. For this reason, the energy costs are directly proportional to the contaminant load. Moreover, the high selectivity of the SPELL process excludes any unwanted reaction and thus any generation of sludge or byproducts, thus avoiding extra power consumption. On average, the specific energy consumption is around 17 kWh/kg of total nitrogen contaminants (see Fig. 1).

By contrast, the biological treatments are inherently inefficient, as they oxidise the ammonium nitrogen in two complex and

sensitive steps: nitrification and denitrification, respectively performed by specific autotrophic and common heterotrophic microorganisms (e.g., *Pseudomonas*, *Micrococcus*, *Archaeobacter*, *Bacillus*, *Spirillum*). During the nitrification process, the autotrophic bacteria extract energy for their life function though the ammonium nitrogen oxidation to nitrate ion (equation 3), using carbon dioxide as their source of carbon instead of organic compounds. Nitrification is an aerobic process and requires eight electrons commonly provided by system aeration, which is a cost element of the process.

Nitrification reaction:

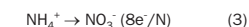

The denitrification process is operated by the heterotrophic microorganisms under anoxic condition and requires five electrons (equation 4). These electrons are usually provided by a carbon source and, while municipal waters are usually rich in carbon, industrial streams are usually inorganic and require dosage of a supplement (e.g., acetic acid or methanol) which translates into additional costs and more polluting materials. This represents another typical and significant cost element of biological treatments.

Denitrification reaction:



Furthermore, biological systems are prone to the intrinsic weakness of bacteria-based processes: occasional failures due to toxic shocks, low/high temperatures sensitivity, process inhibition by fluctuations of nitrogen inflow, and high operational complexity. Nonetheless, the biological treatment is the most widely used technology today and it is generally accepted to cover the widest range of cases and combine reasonable efficiency with deployment costs. In the present scenario, SPELL promises to be an innovative, sustainable, and advantageous alternative to biological systems for the removal of nitrogenous contaminants.

The intrinsic effectiveness of the reaction is translated in the compactness of the system. The core of the system consists of only the SPELL reactors and the degassing tank.

The SPELL reactors contain electrodes coated with special catalysts, the unique feature of the technology. When the contaminated effluent water comes into the reactor, a selective reaction is triggered by the application of the electric current.



Each reactor is fed through a dedicated rectifier, providing the necessary electricity. The ammonia and the urea contained in the water are decomposed into nitrogen, hydrogen, and carbon dioxide in the gaseous state. A mixed-phase stream exits the reactor and enters the degassing tank. Here, the gases are separated by the water to be released to the atmosphere or, in case of reasonable quantities of released gases, are captured for useful applications. A blower installed on top of the tank ensures the proper separation of gases, while the treated water is pumped away, to be possibly recycled back into the process, or eventually discharged.

To complete the system, a filtration unit and chemical dosing packages are usually provided. The filtration unit is often required to reduce the suspended solids in the incoming stream, thus avoiding damage to the cells and reducing maintenance. A minimum chemical dosing is often required to balance the conductivity and the alkalinity of the effluent water.

The system is surprisingly flexible in its operability and can be properly designed to manage wide fluctuations of contaminants and flows thanks to a generous turndown ratio. In the event of exceptionally high levels of contaminant, the design capacity of the system can be conveniently limited by means of a simple recirculation of the effluent water into the electrolytic reactor.

The SPELL process is able to treat effluent water with contamination from tens to hundreds of ppm of nitrogenous compounds and remove them to near zero levels. Inlet streams may be pre-treated to ensure proper operation and protection of the system. Table 1 reports thresholds for the main parameters with which the inlet stream must comply to guarantee the design system availability and design life. Three main levels are described to identify: the "design basis" values, which are defined for the normal operation of the electrolytic cells, the "maximum recommended" values, which can be considered as the "design conditions", and the "maximum allowable" values, over which the technology should not be exposed. Limitations for the total suspended solids are envisaged to keep the electrolytic cells free of depositions, thus reducing the system maintenance. In fact, the total suspended solids figure is related to relevant particle size: the lower the size of the particles, the higher the value of TSS can be considered, over certain limits.

Table 1: Wastewater parameters required at electrochemical reactor inlet

Parameter	Design basis	Maximum recommended	Maximum allowable
TSS, mg/l	< 30	≤ 50	≤ 80
Particle size, micron	< 100	≤ 150	≤ 200
BOD (soluble), mg(O <sub>2</sub> )/l	< 50	≤ 100	-
Hardness, mg/l as CaCO <sub>3</sub>	< 2,000	≤ 5,000	-
Oil and grease, mg/l	< 0.5	≤ 1	≤ 2
pH	≥ 7	≥ 6	≥ 6
Temperature, °C	10-45	10-50	70
Feed pressure, bar(g)	0.5-3	0.5-6	-

Source: Saipem

No technology failure or serious drawbacks are associated with high values of biological oxygen demand (BOD) and/or hardness; good process response and experience have been gained within these conditions.

On the contrary, oil and grease should be minimised as much as possible as these contaminants are able to compromise the proper operation of the system and its integrity.

The pH has its own reference operating range and can be easily managed by chemical dosage.

The temperature of the incoming water should be limited to the values given; higher water temperatures could compromise the coating of the special electrodes.

The system is simple and modular, different contaminant loads and flow volumetric capacities may be fitted by multiple cells, units, and different configurations. It can be simply deployed for brownfield applications, plant enhancements, and greenfield installations. For treatment of complex wastewaters, the SPELL technology can also be used economically in combination with different physical, biological, and chemical processes. A standard N+1 philosophy is usually applied for the electrolytic cell installation to provide adequate system availability.

Figs 2 to 5 provide examples of the performance of the SPELL technology.

Fig. 6 represents a simplified benchmarking exercise comparing the features and advantages of a standard biological treatment versus SPELL.

The first considerations are relevant to the chemical process and its direct implication. Both the biological treatment and SPELL allow for the removal of both ammonia and urea from wastewaters. Urea

decomposes in water to ammonium nitrogen by a two-step reaction which is then further processed either via the sequence of nitrification and denitrification processes in the case of a biological system, or through direct oxidation in the case of SPELL. The two systems are quite different in process efficiency and effectiveness. This difference is amplified by the respective reaction order: biological processes are characterised by first order reactions, suffering a slowdown in rate as the contaminants decrease in concentration, while the electrochemical process is a zero-order reaction, maintaining the same reaction rate independently from the concentration of the contaminants at the inlet. Furthermore, while the biological treatment allows limited concentrations of nitrogen at the inlet, because of inhibition phenomena, the SPELL technology can also treat highly contaminated streams. In fact, the electrochemical technology is not limited by the concentration of the contaminants, but by the cost competitiveness of other technologies in such conditions (e.g., the stripping process becomes the technology benchmark for inlet concentrations of thousands ppm). Since the electrolytic process does not use bacteria, it does not produce any sludge, unlike biological systems. Sludge removal, treatment, and disposal incurs an operational cost which is a feature of biological systems that can be completely avoided by the deployment of SPELL. Another operational cost which can be avoided by the deployment of the electrochemical process is the use of an external carbon source required by bacteria during the denitrification process. Both biological and SPELL processes need chemical dosage; the required quantities are significant for biological systems, but lower for SPELL.

decomposes in water to ammonium nitrogen by a two-step reaction which is then further processed either via the sequence of nitrification and denitrification processes in the case of a biological system, or through direct oxidation in the case of SPELL. The two systems are quite different in process efficiency and effectiveness. This difference is amplified by the respective reaction order: biological processes are characterised by first order reactions, suffering a slowdown in rate as the contaminants decrease in concentration, while the electrochemical process is a zero-order reaction, maintaining the same reaction rate independently from the concentration of the contaminants at the inlet. Furthermore, while the biological treatment allows limited concentrations of nitrogen at the inlet, because of inhibition phenomena, the SPELL technology can also treat highly contaminated streams. In fact, the electrochemical technology is not limited by the concentration of the contaminants, but by the cost competitiveness of other technologies in such conditions (e.g., the stripping process becomes the technology benchmark for inlet concentrations of thousands ppm). Since the electrolytic process does not use bacteria, it does not produce any sludge, unlike biological systems. Sludge removal, treatment, and disposal incurs an operational cost which is a feature of biological systems that can be completely avoided by the deployment of SPELL. Another operational cost which can be avoided by the deployment of the electrochemical process is the use of an external carbon source required by bacteria during the denitrification process. Both biological and SPELL processes need chemical dosage; the required quantities are significant for biological systems, but lower for SPELL.

Fig. 2: Electrochemical system for total ammonium nitrogen removal, main treatment

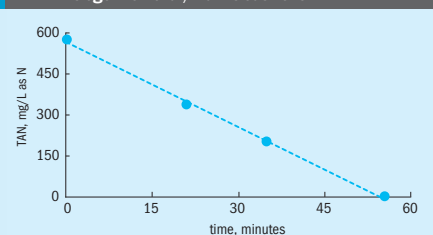

Source: Saipem

Fig. 4: Electrochemical system for total ammonium nitrogen removal, polishing treatment

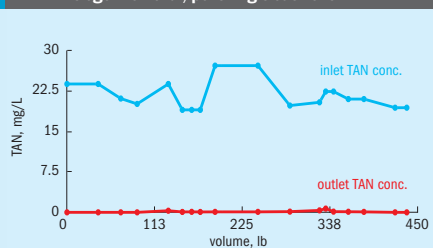

Source: Saipem

Fig. 3: Electrochemical system for simultaneous removal of total organic carbon and total nitrogen

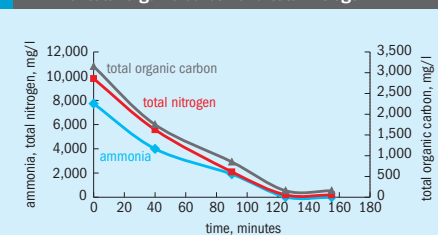

Source: Saipem

Fig. 5: Electrochemical system for total ammonium nitrogen removal, semi-industrial system results

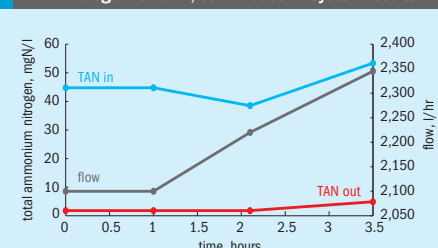

Source: Saipem

Other parameters relevant to the system operability include robustness and flexibility. While biological systems do not adapt well to load and contaminant fluctuations, SPELL manages changes in the inlet parameters much more readily. Even variations of the water temperature can destabilise a biological process, while the electrolytic process allows a wider range of inlet temperatures. Operators commonly find biological processes can be very difficult to manage, and the effectiveness of the process is too often impacted by external conditions. On the contrary, the SPELL process is simple, easy to operate and achieves expected results. The system can be fully automated and even work on a start and stop basis, with immediate start-up and shutdown procedures.

The two processes are also quite different in the number of installed items. For the whole system footprint, biological systems need big concrete basins and operational space, while SPELL is typically more compact requiring limited space.

Based on these considerations, there is clearly a substantial difference in the operational costs, related to typical

consumptions: carbon sources and other chemicals, sludge disposal, electricity for aeration, pumps, etc. for biological processes, which exceed the cost for electricity (for the reactions) and the small amounts of chemicals required for the operation of an entire electrolytic system. Based on Saipem experiences and projections, the operational cost for SPELL is at least half the typical cost for a biological system, with further optimisations possible in certain applications.

The capital expenditure for SPELL may be lower, or at least comparable, to the cost of a biological system designed for the same service, depending on process and site conditions. In some installations, alternative materials (like plastic) can be used instead of steel, thus reducing the overall cost.

Saipem's newly introduced electrochemical technology is an important step towards the overall objective of zero industrial pollution, showcasing the company's deep commitment to global sustainability. SPELL technology is regarded as a breakthrough solution for fertilizer plants as well as other sectors and is ready for

commercialisation on a large industrial scale. Saipem's technology partner, Puramon Ltd, already has two industrial references, demonstrating the effectiveness and advantages of SPELL.

Both of these existing installations are a good example demonstrating technology application for plant enhancements.

The first installation was delivered to a fertilizer plant in the Middle East, with a basic standard configuration for direct ammonia removal. The delivered system treats wastewaters to reduce the contaminating ammonia from 800 to 1.5 ppm. The client (a local fertilizer company), being subject to restricted environmental regulations for effluent discharge to sea, had to plan a dedicated wastewater treatment unit. The electrochemical technology was selected after comparing three leading biological processes for their cost effectiveness, system operability, system reliability, and effluent quality. The system was built, installed, and integrated within the existing facilities in six months and with no requirements for civil engineering works. The new system allowed the client to overcome specific site

Fig. 6: Technology benchmark

BIOLOGICAL TREATMENT		SPELL TECHNOLOGY	
feasible	urea removal	feasible	
not allowed (nitrification inhibition)	nitrogen high concentration	allowed	
first (with possible inhibition)	reaction order	zero	
yes	sludge production	none	
required	external carbon source	not needed	
high (methanol, phosphoric acid)	chemical handling	low to medium	
not feasible (high inertia)	operation on demand	feasible (depending on specific site)	
narrow range of operating temperature	stress resistance	wide range of operating temperature	
site dependent	process results	continuous compliance	
high	operation/maintenance	low to medium	
high	number of items	low to medium	
high	footprint	low	
medium	capex	low to medium	
medium	opex	low	

Source: Saipem

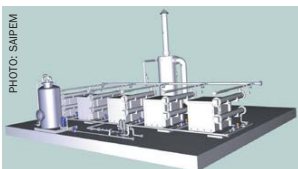

Fig. 7: 3D model of a SPELL plant.

challenges, including a wide fluctuation in nitrogen load at the inlet, and limited availability of space.

Fig. 7 shows a 3D model for a 2.15 m x 16 m plant for a flow of 40 m<sup>3</sup>/h and effluent ammonia of below 1.5 mg/L, based on the new electrochemical technology.

The second installation was delivered for a chemical production facility in Southeast Asia. The client, an international chemical company, had occasional incidents of environmental pollution with ammonia. The existing biological treatment needed a second barrier against such failures since, occasionally, toxins and inhibitors heavily affected the autotrophs in the biological reactor: the existing bacteria based treatment could no longer guarantee consistent compliance with the regulations. A 7-m<sup>2</sup>/h electrochemical unit was installed in combination with the existing ion exchange resins to work on an on-demand operating mode and was designed to reduce ammonia levels from 30 to 5 ppm. The unit was smoothly integrated within the existing wastewater treatment plant, requiring minimum



Fig. 8: A view from inside a SPELL demonstration unit.

footprint, and causing no interference with the ongoing chemicals production.

In addition, to provide evidence of the effectiveness, simplicity, and operability of SPELL technology, Saipem has a demonstration unit (Fig. 8) that can carry out on-line tests, directly at the clients' premises. The SPELL demo plant is fully enclosed in a high-grade, 40-foot container, which can be easily transported everywhere and easily connected with existing, running plants. The system is "plug and play" and is equipped with a few standard connections for the minimum utilities that are required for its operation, namely: pressurised air for instrumentation, electricity supply to sustain the reaction, potable water for safety eye showers.

The system can be fed with a wastewater side stream of the existing wastewater treatment plant, requiring minimum

2 m<sup>3</sup>/h, with a design nitrogen load of 170 g N/h (a concentration which is quite typical for fertilizer plants). The unit is complete with all safety and shutdown systems and is fully compliant with applicable international standards.

The system is ready and is presently undergoing its factory acceptance test. First on-site tests have already been booked. ■

#### References

- Muddemann T., Haup D., Sievers M., Kunz U.: "Electrochemical reactors for wastewater treatment", Wiley-VCH Verlag GmbH & Co. KGaA ChemBioEng, 6, No. 5, 142-156 (Rev 2019).
- Brinkmann T., Santonja G.G., Yükele H., Roudie S., Sancho L.D.: "Best available techniques (BAT) reference document for common waste water and waste gas treatment/management systems in the chemical sector", Industrial Emissions Directive 2010/75/EU Integrated Pollution Prevention and Control.

# because the future needs clean air

Our most efficient scrubbing technology  
with the lowest emissions:

## THE MICROMIST™ VENTURI SCRUBBER

- Easy installation due to modular design
- Meets new stringent emission regulations
- Demonstrated high performance collection of submicron particulates
- Combined urea dust and ammonia scrubbing

To learn more about the benefits of the MICROMIST™ VENTURI SCRUBBER:  
[www.stamicarbon.com/what-we-do/urea/evolve](http://www.stamicarbon.com/what-we-do/urea/evolve)



The innovation & license company  
of Maire Tecnimont.



CONTENTS

What's in issue 374

COVER FEATURE 1

The slowing  
MTO boom

COVER FEATURE 2

Barriers to trade

COVER FEATURE 3

Green technologies

COVER FEATURE 4

Wastewater  
treatment

NITROGEN+SYNGAS  
**ISSUE 374**  
NOVEMBER-DECEMBER 2022

# BCInsight

Southbank House, Black Prince Road  
London SE1 7SJ, England  
Tel: +44 (0)20 7793 2567  
Fax: +44 (0)20 7793 2577  
Web: [www.bcinsight.com](http://www.bcinsight.com)  
[www.bcinsightsearch.com](http://www.bcinsightsearch.com)



# Wastewater treatment in a urea plant

A detailed rain and wastewater concept is an important part of a urea plant to meet current stringent environmental standards. Wastewater can originate from the process reaction or from outside the process equipment. In order to optimise the wastewater system of a urea plant, both the amount and type of contamination need to be known. With this knowledge, non-contaminated rainwater as well as process drains can be kept separate as much as possible to minimise the amount of wastewater to be treated, saving costs and energy. Wastewater treatment concepts from thyssenkrupp Industrial Solutions and Toyo Engineering Corporation are described.

## THYSSENKRUPP INDUSTRIAL SOLUTIONS

### State-of-the-art wastewater collection, handling and avoidance management

As a urea contractor for greenfield and revamping projects, thyssenkrupp Industrial Solutions has the knowhow and experience to provide a wide range of local and climate-specific solutions for state-of-the-art wastewater collection, handling and avoidance management for urea plants and the downstream offsites and utility systems.

In a urea plant the reaction of ammonia and CO<sub>2</sub> via carbamate ultimately produces urea and water:

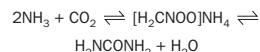

This water, the so-called process condensate or ammonia water, is separated from urea by evaporation. As it contains reasonable amounts of ammonia and also urea, it is purified before it is discharged from the urea plant and transferred to offsites and utility units for further use and treatment. Urea plants built by thyssenkrupp Industrial Solutions, using the Stamicarbon urea synthesis process, discharge the process condensate with less than 1 ppm of ammonia and 1 ppm of urea to the wastewater treatment section. Due to its suitable quality for reuse, the urea process condensate is not considered as waste but as a recycle stream to the water treatment facility, where the process condensate is subject to further treatment. Filtration and ion exchange allow the condensate to be treated to produce

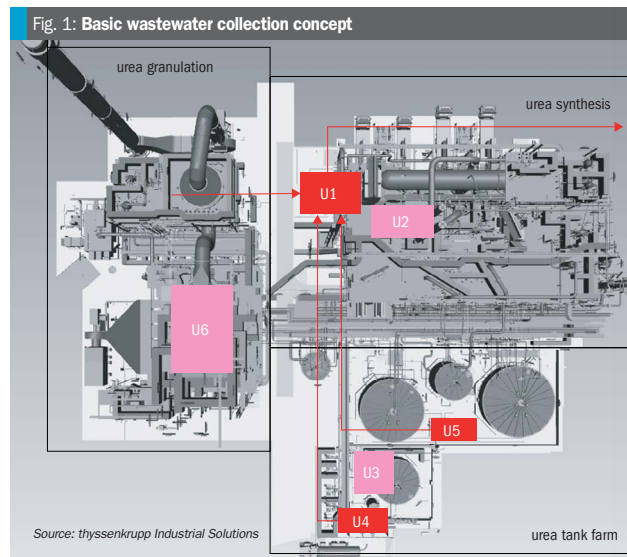

demineralised water quality suitable for high pressure steam production.

Wastewater from outside the process equipment originates from rain or open process drains (e.g., pump seals). As this wastewater can possibly contain ammonia and urea as well as other contaminants

such as oil, it must also be accurately collected, treated, and discharged from the urea plant. At best contamination can be avoided and rainwater purely discharged into the clean stormwater system, which is a sewer system, usually connected to the public sewer grid.

Table 1: Basic wastewater collection concept

Pit	U-1	U-2	U-3	U-4	U-5	U-6
Description	wastewater collection pit in synthesis section	drain vessel in synthesis section	drain vessel for UF and acid tanks	wastewater pit at truck loading site	wastewater pit at urea storage	recycle vessel in granulation section
Source of wastewater	rainwater + oily wastewater	process	process + spillages	rainwater + leakages	rainwater + leakages	process
Target	offsites and utilities	process	process	U-1	stormwater, U-1 if contaminated	process

Source: thyssenkrupp Industrial Solutions

### Basic concept for wastewater and stormwater collection

There can be several trench systems, piping and pits in the urea plant to collect rainwater. Fig. 1 and Table 1 explain a typical arrangement that can be found in plants built by thyssenkrupp Industrial Solutions. There are three main areas in a urea plant: synthesis building, granulation building and tank area.

This basic concept can be extended and adapted to the layout or climatic conditions as required. There are six wastewater pits located in the urea plant area. The three pits U-2, U-3 and U-6 collect wastewater which is then returned back to the urea process for direct reuse, U-2 from synthesis, U-3 from the diked urea storage area in which the acid storage vessel and the UF tank are located, and U-6 from the granulation section. There are three other pits that collect wastewater from drains, granulation washing and stormwater: Pit U-5 is located in the diked urea storage area in which the urea solution and the ammonia water tank are located. If the water in U-5 is not contaminated (pure rainwater without spillages) it is disposed of in the stormwater system. If contamination has occurred (e.g., spillages or leaking tanks), the water is routed to the central wastewater pit U-1 in the synthesis area. Pit U-4 collects wastewater from the truck loading area for an acidic storage vessel and a urea formaldehyde tank. The solution collected in pit U-4 is sent to pit U-1. Pit U-1 in the synthesis area is equipped with an oil separator and also collects stormwater from the granulation and synthesis sections from an open trench system. After oil separation the wastewater is sent to the offsites and utilities plants for further treatment.

### Recovery of waste streams

As urea is a crystalline product, some dedicated pump seals have to be flushed with tempered water (API Plan 32). For pumps

handling urea or carbamate solution at a higher concentration a combination of different seal flush setups is used. Just before start-up or shutdown a seal flush with clean hot condensate (API Plan 32) is applied to ensure that there is no crystallisation inside the pump seal, which would damage the seal and lead to leakages of urea or carbamate solution into the wastewater system. During normal operation, when it can be assured that the process media delivers enough heat by itself to prevent any crystallisation, the seal flush can be switched to process media from the discharge side of the pump (API Plan O1 or 11). During operation of the pump a steam quench on the atmospheric side of the pump seal (API Plan 62) ensures that no possible leakage leads to a build-up of crystalline urea, which might damage the seals. As steam condenses at the outer seal, this condensate needs to be collected continuously. For urea melt pumps with a hydrodynamic seal can be used, which tolerates even a small solid content inside the process media. In order to avoid wastewater, a seal system is usually constructed in such a way that the seal water is flushed into the process. If the seal system fails, process medium may be leaked from the pump seal into the environment. The medium released is collected and discharged into pipes. The water that escapes from the pump seals in the synthesis area is collected in pit U-2 (see to Fig. 1) and returned to the urea synthesis section. The water from the pump seals in the granulation area is collected in pit U-6 (see Fig. 1) and returned to the recycle vessel in the granulation section. From there, it is recycled to the process.

Nowadays, the granulation section is usually equipped with both dust and acidic scrubbers to remove dust as well as ammonia from the granulation air. The two acids most often used to capture the ammonia are sulphuric acid and nitric acid. Sulphuric acid and the ammonium sulphate formed

from the reaction with ammonia can be recovered together with the urea, so that it finally ends up in the product together with urea by application of the so-called Ammonia Convert Technology (ACT). Consequently, such streams can be collected in the recycle vessel U-6. Nitric acid and ammonium nitrate cannot be mixed with the urea, so these streams are collected in a dedicated pit (not shown in Fig. 1). From there, unreacted nitric acid can be reused in the acidic scrubbing stage of the vent gas scrubber, while ammonium nitrate needs to be discharged e.g., to a UAN plant.

### Avoiding rainwater contamination

Rainwater falls onto all surfaces of a process plant. If rainwater comes into contact with process media or oil, e.g., from the lubricating greases of pumps, it is contaminated and must be drained off separately and reprocessed. The best measure is always to avoid contamination. Mitigation is always the preferred measure compared to treatment. Especially in tropical regions, avoiding contamination is key. This is achieved by covering pumps and tanks. In a urea plant, there are several tanks in the tank farm. This area is usually free of process fluids and oil. Nevertheless, in case of leakage or spillages, contamination of the rainwater may occur. The rainwater is collected in a pit in the tank cup and pumped away. Since the tank cup and the tank itself are very large and have a correspondingly large area on which the rain falls, the amount of water can also be quite large. Especially in tropical regions, this can lead to problems, e.g., when designing the required capacities for wastewater pumps and oil separators. If needed, therefore, thyssenkrupp Industrial Solutions builds rain gutters on the tank so that the tops of the tanks act as collecting roofs as shown in Fig. 2. The rain falling on the tank roof is not contaminated and can be directly drained to the clean stormwater

Table 2: Design requirements for water collected in pits for a location in North Africa

Specification/pit	U-1			U-4	U-5
	Wastewater collection pit in synthesis			Truck loading	Tank farm
Mode of operation	normal	hourly max flow	max. urea	normal	normal
Frequency	continuous	intermittent	intermittent	intermittent	intermittent
pH	6-9	< 6 possible	< 6 possible	6 - 9	6 - 9
Typical flow rate, design, m <sup>3</sup> /h	1*	63*	40*	10*	40*
Temperature, °C	ambient	ambient	ambient	ambient	ambient
Urea (max.), %	traces	0.75	3	traces	traces
Urea formaldehyde, %	traces	traces	traces	traces	traces
Acid, %	traces	traces	traces	traces	
Ammonium salt, %	traces	traces	traces		
Oil, %	traces	traces	traces		
Ammonia, %	traces	traces	traces		traces
Disposal to	wastewater treatment (e.g. neutralisation)	wastewater treatment (e.g. neutralisation)	wastewater treatment (e.g. neutralisation)	U-1	U-1
Origin	drains	drains, washing activities in granulation, stormwater	drains, washing activities in granulation	stormwater	stormwater

\* the design flow rate depends on climatic conditions as well as the dedicated paved area.  
Source: thyssenkrupp Industrial Solutions

Fig. 2: Tropicalisation of a tank farm

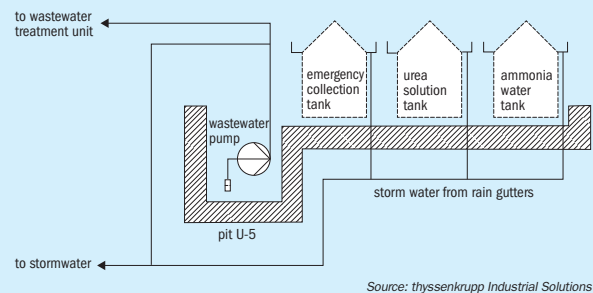
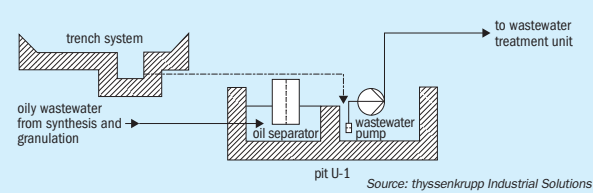

Fig. 3: Separation of oily wastewater from non-oily wastewater



system. For light and medium rainfall, the remaining water in the tank farm can evaporate. In case of high rainfall, it is collected in pit U-5 and can be discharged by pump (see Fig. 2). Provided any contamination is within the permissible emission range, it can then be discharged to the clean stormwater system. In case contamination exceeds the permitted levels, the stormwater is pumped directly to the offsites and utilities for further treatment.

The steel structure of the synthesis section can be roofed over so that rainwater cannot contaminate the area. Additional cladding can prevent rain from entering from the side, e.g., during strong winds. Whether roof and cladding are necessary is a trade-off between investment costs and the resulting wastewater load. Since thyssenkrupp Industrial Solutions absorbs the risk of contamination from machines, cladding is not necessary in thyssenkrupp Industrial Solutions plants. The granulation building is usually enclosed due to process needs, so no further measures are necessary there. Granulation also includes a so-called wet section including the scrubbers for dust removal from the granulation air. Nowadays, this scrubbing system usually includes an acidic stage for reducing

ammonia emissions. Due to the possible contamination with media from the wet section, rainwater that falls on the surface of the wet section is collected in trench systems and discharged from the plant via wastewater collection pit U-1.

To reduce the oil load in the wastewater, machines can be enclosed or covered so that no oil can be washed away by rain. In case machines cannot be roofed, dedicated catch basins can collect any water that may accumulate and direct it to the oil separator in the pit U-1 shown in Figs 1 and 3 by means of a closed pipe system. Base frames with drip pans can be considered for machines where applicable to minimise cross-contamination with water as much as possible and to keep contamination local, i.e., to keep dedicated areas curbed and separated.

In addition to the aforementioned measures of using tank roofs to drain clean rainwater and covering the roofs of steel structures or directing the wastewater depending on the waste load to stormwater or offsites and utilities, thyssenkrupp Industrial Solutions also uses other measures to keep the overall amount of wastewater low. thyssenkrupp Industrial Solutions has already built many plants in different locations, with different climates. Most recently, tropicalisation was used in a plant located in Southeast Asia contributing to a reduced energy requirement due to reduced treatment requirements.

An effective measure is to cover the open ends of funnels with a removable cover so that rainwater cannot penetrate. Rainwater from areas potentially contami-

nated with oil or grease is channelled separately through an oil separator as shown in Fig. 3.

Wastewater from places without potential oil contamination is routed downstream of the oil separator. In this way, the oil separator remains efficient even with high rain loads and can be dimensioned appropriately.

Table 2 shows the design requirements for water collected in pits and representative requirements for a location in North Africa. Flow rates will vary depending on the precipitation of the geographic location as well as the amount of paved area. Pits U-2, U-3 and U-6 are not indicated because the solution is recycled back to the process for direct reuse, thus mitigating wastewater disposal.

TOYO ENGINEERING CORPORATION

TOYO zero effluent approach to wastewater treatment

Toyo Engineering Corporation (TOYO) applies a zero effluent approach to wastewater treatment in urea plants to meet current stringent environmental standards.

Different types of wastewater are generated in the urea plant, some of which need to be treated before discharge outside the urea plant.

TOYO's wastewater treatment for urea plants can be broken down into treatment and disposal methods for the following types of wastewater:

- process drain water;
- process condensate;
- oily water;
- contaminated surface drain water including rainwater.

Process drain water

Since process drain water contains a large amount of urea, carbamate, and ammonia, it is essential to store the drain water in the pit or tank for reuse it in the process. The capacity of the pit or tank must be carefully determined to prevent liquid overflow from the system

Fig. 1: TOYO urea process

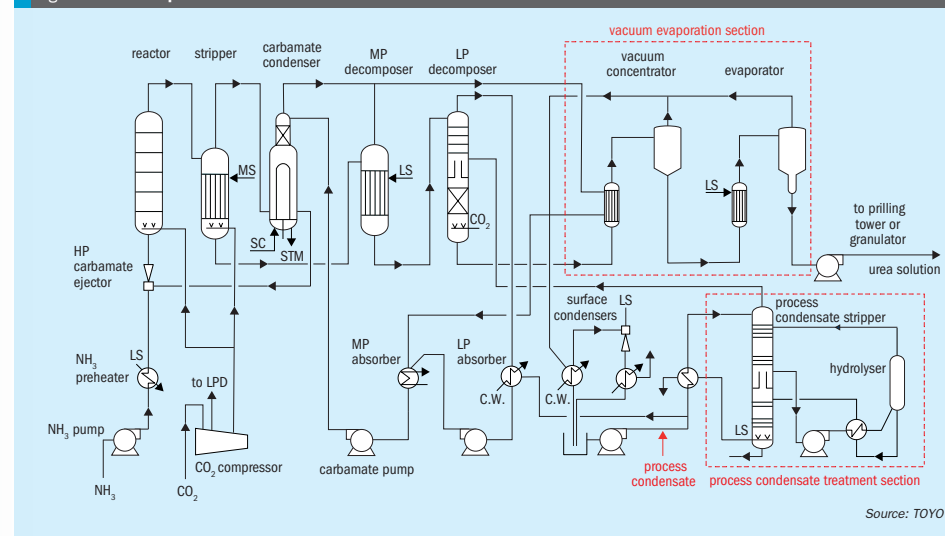



Fig. 2: Process condensate treatment with on-line analyser

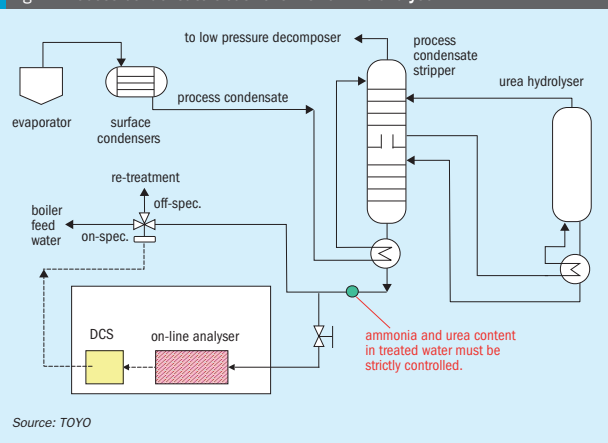
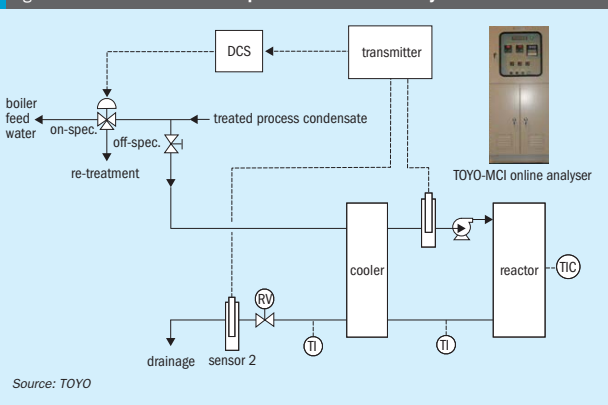

Fig. 3: Schematic flow of on-line process condensate analyser



e.g., during upset conditions, start-up or shutdown.

**Process condensate**

Water (process condensate) is the largest by-product of the urea production process. Stoichiometrically, 0.3 tonne of water is produced per tonne of urea, but in industry it can be as high as 0.5 t/t-urea. The treatment of process condensate containing ammonia and urea has been a challenge since the urea production process was industrialised. Water as a by-product is evaporated in the vacuum evaporation section of the urea plant and sent to the

process condensate treatment section. Fig. 1 shows the process flow of the typical urea plant. In the process condensate treatment section, deep urea hydrolysis and steam stripping technology reduces the urea and ammonia content to lower than 1 ppm, enabling the treated process condensate to be used for make-up for boiler feed water (BFW). When using the treated process condensate for BFW make-up, the urea content must be strictly controlled because urea cannot be removed in an ion-exchange resin bed. In case of excessive urea in the BFW, it is hydrolysed in a boiler to form carbon dioxide which lowers the pH but can result in excessive

corrosion in the boiler. As the conductivity meter, which is typically installed at the line of treated condensate, does not show the level of urea content (urea does not become electrolytes in aqueous solution), urea in treated process condensate must be periodically analysed in a laboratory and it typically takes a few hours to obtain the urea analysis results. To eliminate the risk of corrosion in the boiler due to low pH caused by excessive urea in BFW, the urea of the treated condensate should be analysed continuously in real-time. TOYO and Mitsui Chemicals Inc. (MCI) have developed a proprietary online urea analyser for the treated process condensate, which analyses urea continuously in real-time in the range from 1 ppm to hundreds of ppm. As the TOYO-MCI online urea analyser is simply configured and does not require any chemicals and reagents, its initial and running costs are fairly low. Figs. 2 and 3 show an example of its application and schematics of the analyser. The TOYO-MCI online urea analysers have been running in TOYO's urea plants for more than a decade. The TOYO-MCI online analyser can be installed for the rigorous control of process condensate quality in all existing urea plants in the world.

**Oilly water**

As major rotating machines have a dedicated lube oil system, during maintenance periods some lube oil may spill onto the paving area and contaminate floor washing water or rainwater. This effluent (oilly water) should be segregated from other types of effluent because the removal of oil requires specific technology for the treatment. As such, the area where oilly water is generated should be enclosed and isolated from other areas. The collected oilly water is sent to a dedicated oil separator, for which API oil-water separator or CPI separator is predominantly used, for the separation of oil. As some oil still exists even after the treatment by such gravity-type oil separators, another type of technology, e.g., a coalescer can be used in conjunction with oil separators, depending on local regulations or end-user's requirements. It is necessary to identify and carefully discuss with the end-user which rotating machine is to be targeted for the treatment of oily water and decide on a segregation plan during the initial phase of a project so that unexpected oil contamination does not happen.

Fig. 4: TOYO's effluent treatment plant

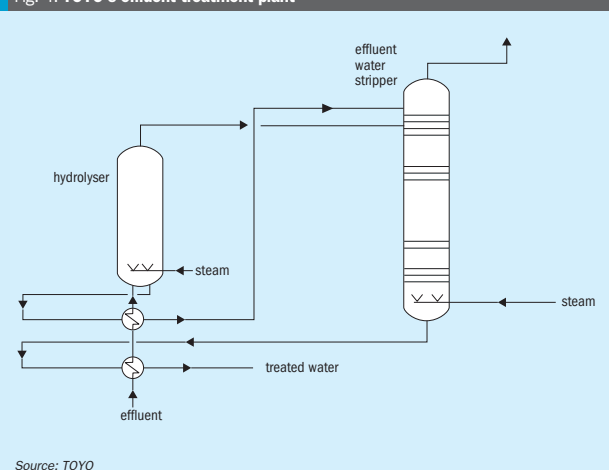
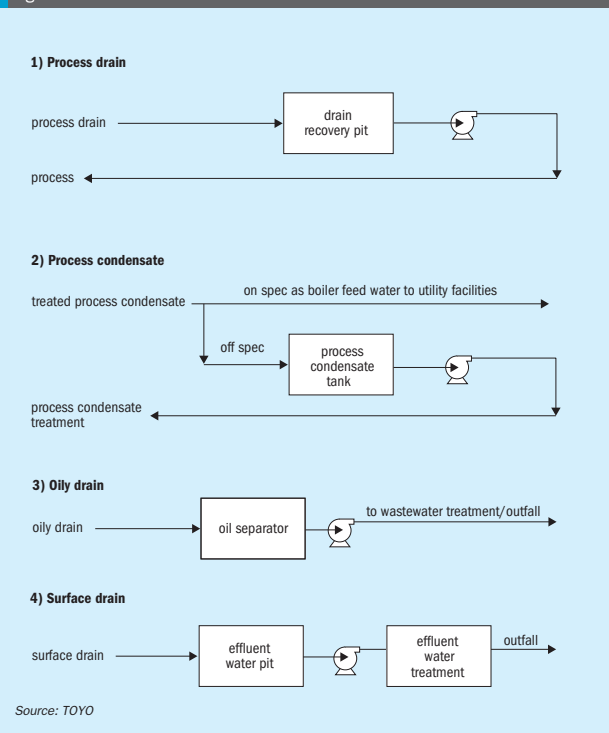

Fig. 5: Outline of wastewater treatment methods



**Contaminated surface drain water including rainwater**

Floor washing water and rainwater in the paved area may also be categorised as wastewater in some circumstances. In the urea plant, urea or carbamate may spill onto the paved area due to a variety of reasons, such as local maintenance activities or an unforeseen leakage from piping flanges. If it rains during the period when the process fluid spillage occurs, or when floor washing water is used to clean the spillage, it is possible that the process fluid may contaminate the cleaning water or rainwater. The amount of urea, carbamate, and/or ammonia in these wastewaters is often small; therefore, in many instances, they have just been diluted by another water and discharged to the outside of the urea plant. Even now, depending on local regulations, some urea plants still apply this method in combination with a neutralisation system; however, considering the growing environmental interests in the world and the difficulty of removing urea by the neutralisation technique, a dedicated wastewater treatment facility should be used in the urea plant.

TOYO has developed a remarkable wastewater treatment facility that removes urea and ammonia from such surface drain water from the paved area and has installed and operated it in several plants. Fig. 4 shows the schematic process flow of TOYO's effluent water treatment system. The urea contained in the surface drain is first decomposed in the hydrolysis tower and then steam stripping technology is applied to separate the ammonia. The wastewater can be sufficiently cleaned to a level where it can be sent out of the system directly. In general, surface drain water contains a lot of foreign material, which often causes mechanical problems, however, TOYO's robust and careful design provides a trouble-free system.

Fig. 5 summarises TOYO's wastewater treatment and disposal methods. By employing these wastewater treatments in this way, TOYO urea plants do not discharge any dirty wastewater outside of the system, complying with all environmental standards around the world. In future, TOYO aims to contribute to the global fertilizer business while paying the utmost attention not only to the main process performance but also to the environment.

CONTENTS

What's in issue 374

COVER FEATURE 1

The slowing MTO boom

COVER FEATURE 2

Barriers to trade

COVER FEATURE 3

Green technologies

COVER FEATURE 4

Wastewater treatment

NITROGEN+SYNGAS  
**ISSUE 374**  
NOVEMBER-DECEMBER 2022

**BCInsight**

Southbank House, Black Prince Road  
London SE1 7SJ, England  
Tel: +44 (0)20 7793 2567  
Fax: +44 (0)20 7793 2577  
Web: www.bcinsight.com  
www.bcinsightsearch.com

## Advertisers' index

**Editor:**  
RICHARD HANDS  
richard.hands@bcinsight.com

**Technical Editor:**  
LISA CONNOCK  
lisa.connock@bcinsight.com

**Publishing Director:**  
TINA FIRMAN  
tina.firman@bcinsight.com

**Subscription rates:**  
GBP 425; USD 850; EUR 655

**Subscription claims:**  
Claims for non receipt of issues must be made within 3 months of the issue publication date.

**Sales/Marketing/Subscriptions:**  
MARLENE VAZ  
Tel: +44 (0)20 7793 2569  
Fax: +44 (0)20 7793 2577  
marlene.vaz@bcinsight.com  
Cheques payable to BCInsight Ltd

**Advertising enquiries:**  
TINA FIRMAN  
tina.firman@bcinsight.com  
Tel: +44 (0)20 7793 2567

**Previous articles** from Nitrogen+Syngas and Nitrogen & Methanol from 1996 to the present are available digitally in PDF format. To make a purchase, or for a list of available articles, please see: [www.bcinsight.com](http://www.bcinsight.com)

**Copyright: Issued six times per year, or bi-monthly. All rights reserved. No part of this publication may be reproduced, stored in a retrieval system or transmitted in any form or by any means – electronic, mechanical, photocopying, recording or otherwise – without the prior written permission of the Copyright owner.**

ISSN: 1750-6891

**Design and production:**  
JOHN CREEK, DANI HART



**Printed in England by:**  
Buxton Press Ltd  
Palace Road, Buxton, Derbyshire,  
SK17 6AE

© 2021 – BCInsight Ltd

**BCInsight**

**Published by: BCInsight Ltd**  
China Works, Unit 102,  
100 Black Prince Road,  
London SE1 7SJ, UK  
Tel: +44 (0)20 7793 2567  
Fax: +44 (0)20 7793 2577  
Web: [www.bcinsight.com](http://www.bcinsight.com)  
[www.bcinsightsearch.com](http://www.bcinsightsearch.com)

Advertiser	Page	Website
Argus Media Co	13	argusmedia.com
Borsig GmbH	45	borsig.de
Casale	31	casale.ch
Eurotecnica Contractors and Engineers	5	eurotecnica.it
Eurotecnica Contractors and Engineers	OBC	eurotecnica.it
Johnson Matthey	IFC	matthey.com/
Neelam Aqua & Speciality Chem (P) Ltd	19	neelamaqua.com
Nitrogen + Syngas Conference 2022	IBC	crugroup.com/events
Stamicarbon BV	55	stamicarbon.com
Tecnimont Group	11	mairetecnimont.com/en
thyssenkrupp	25	thyssenkrupp-industrial-solutions.com/power-to-x
Ventilatorenfabrik Oelde GmbH	21	venti-oelde.com

### Next issue: January/February 2022

- **Water gas shift – understanding the challenges and catalyst solutions**
- **Superior scrubbing for nitrogenous fertilizer plants**
- **Crisis in global gas markets**
- **The Ammonia Technology Roadmap**

**Closing date for advertisement space booking is 17 January 2022**  
**For further information and to book advertisement space contact:**  
**Tina Firman, Publishing Director: [tina.firman@bcinsight.com](mailto:tina.firman@bcinsight.com)**  
**Tel: +44 (0)20 7793 2567 Fax: +44 (0)20 7793 2577**

35th

CRU

# Nitrogen + Syngas 2022 Conference & Exhibition

28-30 March 2022 • Estrel, Berlin, Germany

## The world's leading technical event returns LIVE and in-person

*“The most important annual European event in N2 & syngas.”*

Esben Sorensen, Technical Sales Director, Haldor Topsoe

**740+**  
Delegates

*“A must attend event for Syngas and Nitrogen producers!”*

Miroslav Dimitrov, Production & Maintenance Manager, Neochim PLC

**330+**  
Companies

**46+**  
Countries

For sponsorship and exhibition opportunities, please contact Michelle Bingham:

[Michelle.Bingham@crugroup.com](mailto:Michelle.Bingham@crugroup.com) +44 (0)20 7903 2159

Official Publications

Fertilizer Week

Ratings Partner

Supported by

Discover why you should attend: [www.nitrogensyngas.com](http://www.nitrogensyngas.com)

#CRUNitrogen

CONTENTS

What's in issue 374

COVER FEATURE 1

The slowing MTO boom

COVER FEATURE 2

Barriers to trade

COVER FEATURE 3

Green technologies

COVER FEATURE 4

Wastewater treatment

NITROGEN+SYNGAS  
**ISSUE 374**  
NOVEMBER-DECEMBER 2022

**BCInsight**

Southbank House, Black Prince Road  
London SE1 7SJ, England

Tel: +44 (0)20 7793 2567

Fax: +44 (0)20 7793 2577

Web: [www.bcinsight.com](http://www.bcinsight.com)

[www.bcinsightsearch.com](http://www.bcinsightsearch.com)



1  
2  
3  
4  
5  
6  
7  
8  
9  
10  
11  
12  
13  
14  
15  
16  
17  
18  
19  
20  
21  
22  
23  
24  
25  
26  
27  
28  
29  
30  
31  
32  
33



# Euromel® Melamine

## The industry benchmark

24 plants worldwide. 5 million tonnes produced. No pollution. Euromel® is the world's leading melamine technology. Over the last 40 years, Eurotecnica has transformed the melamine market into a global operation by creating a melamine process that turns its Urea feedstock into a product that is profitable and in high demand.

Today, 24 melamine plants around the world have been licensed and implemented on the basis of Euromel®, with a combined annual capacity of more than 860,000 tons. Euromel® has also become the process with the lowest OPEX in the industry with zero-pollution, low energy consumption and no chemicals added for purification. Therefore investing in Euromel® means gaining access to a sustainable technology with a global network of producers.

Contact us at [www.euromel.com](http://www.euromel.com) to find out more.

**EUROMEL®**

[www.euromel.com](http://www.euromel.com)

**EUROTECNICA**  
MAKING SUSTAINABILITY PROFITABLE

### Don't forget the next issue of **Nitrogen+Syngas** January/February 2022



CONTENTS

What's in issue 374

COVER FEATURE 1

The slowing MTO boom

COVER FEATURE 2

Barriers to trade

COVER FEATURE 3

Green technologies

COVER FEATURE 4

Wastewater treatment

**NITROGEN+SYNGAS**  
**ISSUE 374**  
NOVEMBER-DECEMBER 2022

**BCInsight**

Southbank House, Black Prince Road  
London SE1 7SJ, England  
Tel: +44 (0)20 7793 2567  
Fax: +44 (0)20 7793 2577  
Web: [www.bcinsight.com](http://www.bcinsight.com)  
[www.bcinsightsearch.com](http://www.bcinsightsearch.com)