

1  
2  
3  
4  
5  
6  
7  
8  
9  
10  
11  
12  
13  
14  
15  
16  
17  
18  
19  
20  
21  
22  
23  
24  
25  
26  
27

# Welcome to our interactive version of **Sulphur** Issue 391

Please use either the buttons on the left or top right of the page to navigate your way around this interactive PDF

**IMPORTANT INFORMATION:**

Copyright – Issued six times per year, or bi-monthly. All rights reserved. No part of this publication may be reproduced, stored in a retrieval system or transmitted in any form or by any means – electronic, mechanical, photocopying, recording or otherwise – without the prior written permission of the Copyright owner.

Number 391

November | December 2020

# SULPHUR

[www.sulphurmagazine.com](http://www.sulphurmagazine.com)

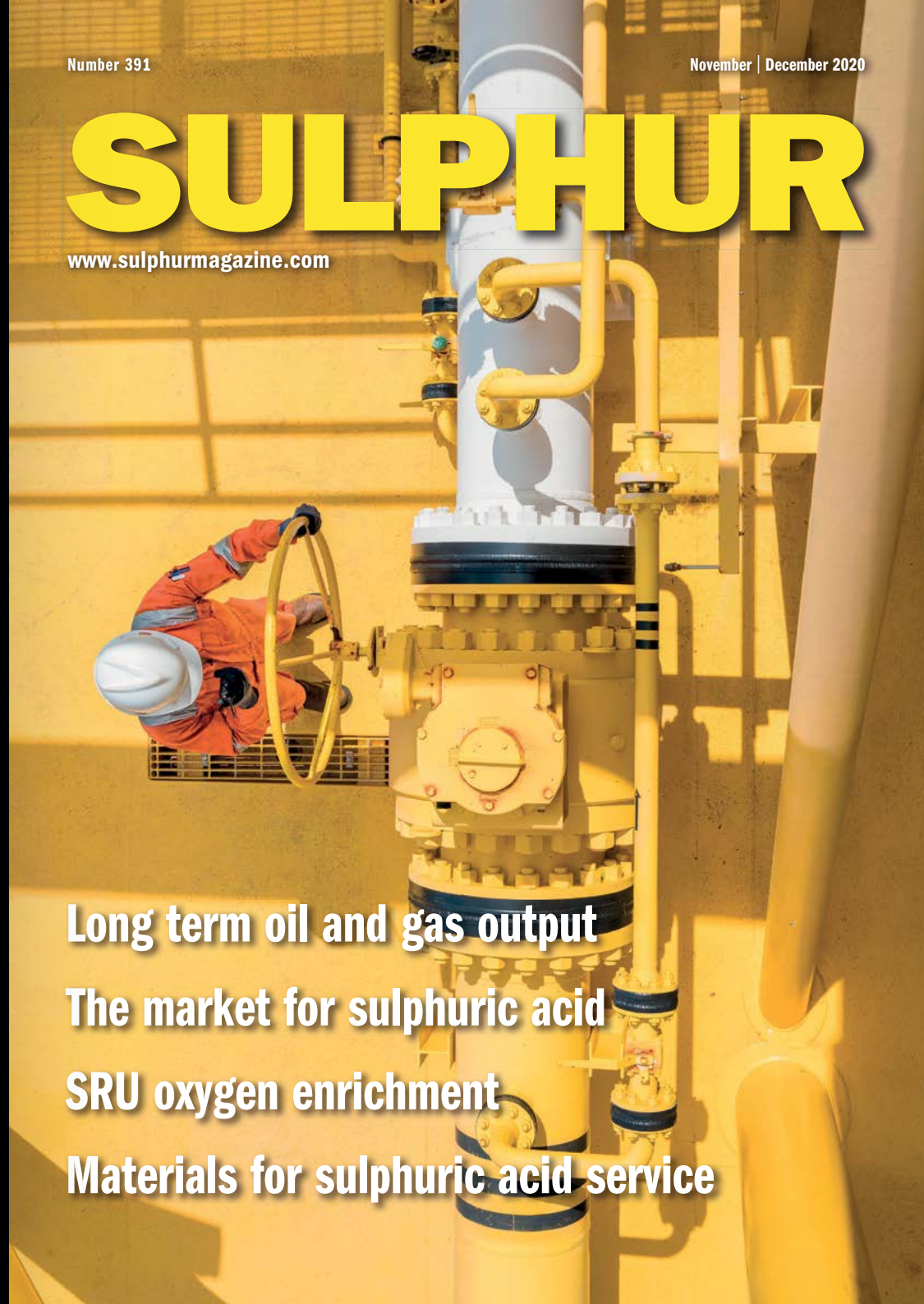

Long term oil and gas output

The market for sulphuric acid

SRU oxygen enrichment

Materials for sulphuric acid service



CONTENTS

What's in issue 391

COVER FEATURE 1

Long term oil and gas output

COVER FEATURE 2

The market for sulphuric acid

COVER FEATURE 3

SRU oxygen enrichment

COVER FEATURE 4

Materials for sulphuric acid service

SULPHUR  
**ISSUE 391**  
NOVEMBER-DECEMBER 2020

**BCInsight**

Southbank House, Black Prince Road  
London SE1 7SJ, England  
Tel: +44 (0)20 7793 2567  
Fax: +44 (0)20 7793 2577  
Web: [www.bcinsight.com](http://www.bcinsight.com)  
[www.bcinsightsearch.com](http://www.bcinsightsearch.com)

# We are everything sulphur

As the recognized world leader for sulphur-related projects, Worley has over 65 years of providing **unique total sulphur and sulphuric acid management solutions** globally. Worley can provide leading technology, plants, equipment and solutions for all parts of the sulphur chain. We are everything sulphur.

Comprimo® Sulphur, Chemetics® Sulphuric Acid, and Advisian Port and Logistics solutions provide world wide focus on site reliability, environmental solutions, plant economics and workforce development.

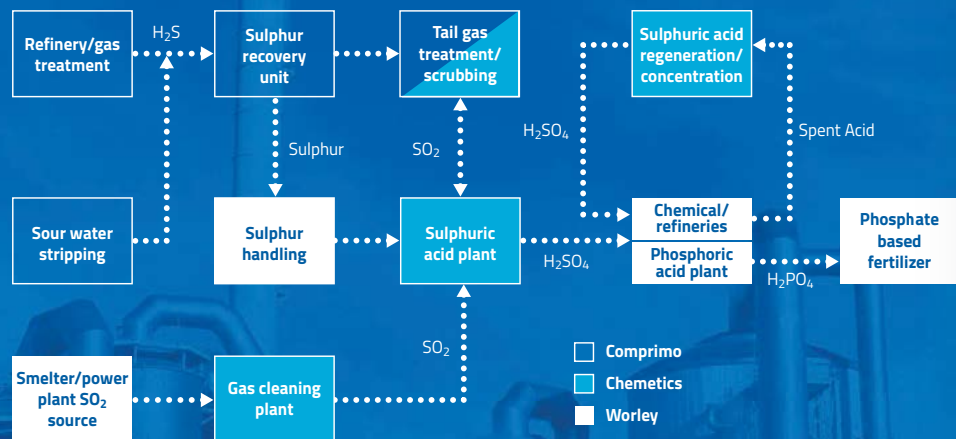

The Hague Vancouver London Toronto Calgary Perth Los Angeles Mumbai Santiago

worley.com/comprimo

worley.com/chemetics



Cover: Oil and Gas Photographer/ Shutterstock.com

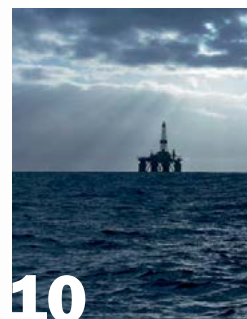

## Oil and gas production

A tighter long term outlook for sulphur



## Oxygen enrichment

New developments for SRUs

Read this issue online at:  
[www.sulphurmagazine.com](http://www.sulphurmagazine.com)

Published by:

**BCInsight**

# SULPHUR

[www.sulphurmagazine.com](http://www.sulphurmagazine.com)

NUMBER 391

NOVEMBER | DECEMBER 2020

## CONTENTS

### 10 Long term trends in oil and gas production

Demand for oil in developed countries was already falling before the coronavirus outbreak, and consumption growth is slowing in the developing world. Peak oil demand may arrive in the next decade. Coupled with more reinjection of sour gas rather than sulphur extraction, could we be seeing falling elemental sulphur production in a decade or so?

### 12 SOGAT 2020

Sulphur reports on this year's Sour Oil and Gas Advanced Technology (SOGAT) conference, which was run as a virtual event at the end of September 2020.

### 13 The year that went viral

A look back at some of the major events of 2020 for the sulphur and sulphuric acid industries, as well as a look forward as to how 2021 might look.

### 14 Sulphuric acid markets

Although 2019 had been a volatile year for acid markets, with shutdowns disrupting supply, the coronavirus outbreak wrought even more havoc in 2020, across both supply and demand.

### 15 New ways with oxygen enrichment technology

New approaches and novel processing schemes employing oxygen enrichment in sulphur recovery units have been developed and commercialised. In this feature Siirtec Nigi, Linde, Blasch, Fluor and RATE report on their latest developments.

### 23 Materials for pumps, valves, and piping in sulphuric acid service

Several highly corrosion resistant materials are available for use in handling process fluids encountered in the production of concentrated sulphuric acid. In this article, M. J. Cooke of Weir Minerals discusses materials of construction for pumps, valves and piping used in the production of sulphuric acid.

### 25 SO<sub>2</sub> emissions reduction using an IIoT solution

A. Bhargav and A. Krishnan of Helium Consulting Pvt. Ltd discuss how it is possible to reduce SO<sub>x</sub> emissions within the existing system setup of an oil refinery or gas plant through detailed analysis, expedited corrective actions and the use of automated algorithms in real-time, by using a digital IIoT solution to monitor, control and optimise.

## REGULARS

- 3 Editorial Can you spare a nickel?
- 4 Price Trends
- 5 Market Outlook
- 6 Sulphur Industry News
- 8 Sulphuric Acid News
- 9 People/Calendar

CONTENTS

What's in issue 391

COVER FEATURE 1

Long term oil and gas output

COVER FEATURE 2

The market for sulphuric acid

COVER FEATURE 3

SRU oxygen enrichment

COVER FEATURE 4

Materials for sulphuric acid service

SULPHUR  
**ISSUE 391**  
NOVEMBER-DECEMBER 2020

**BCInsight**

Southbank House, Black Prince Road  
London SE1 7SJ, England

Tel: +44 (0)20 7793 2567

Fax: +44 (0)20 7793 2577

Web: [www.bcinsight.com](http://www.bcinsight.com)  
[www.bcinsightsearch.com](http://www.bcinsightsearch.com)



# Can you spare a nickel?

**M**etal markets are used to ups and downs, and, as we discuss elsewhere in this issue, this year has seen more than most, mainly thanks to the virus that is still keeping us indoors – as I write this, the UK has just moved back into a second national ‘lockdown’. However, this year has seen the fortunes of one metal in particular simply rise and rise – nickel.

Nickel made a big splash in the sulphuric acid industry during the 90s and 00s as China’s demand for stainless steel began to skyrocket, and deposits of nickel sulphide ore started to become scarce, leading to attempts to exploit lower grade laterite deposits. Laterites are oxidised ores, and harder to extract nickel from, and so numerous producers tried using acid at high pressures and temperatures in the high pressure acid leach (HPAL) process. Around 5 million t/a of acid demand came from new HPAL plants over the period 2010-2015. However, handling acid under such conditions proved technically very challenging, as well as expensive, which became a problem when rival processes began to undercut it. The problem is, if you only need the nickel for stainless steel, then you don’t need to separate the iron from the ore, and can get away with cheaper thermal processes, producing ferronickel or even ‘nickel pig iron’ (NPI). NPI became all the rage in China, and then, when Indonesia started to try and capture more of the value chain by restricting ore exports, in Indonesia too. Couple that with the slowdown in the Chinese economy, and things became very difficult for HPAL producers.

Now, however, the need is not for nickel per se, but for nickel sulphate, and at very high purity levels. The reason, of course, is the burgeoning electric vehicle (EV) market, which needs nickel sulphate for its batteries. Suddenly, high purity nickel is very scarce. Elon Musk, the world’s fifth richest man, has taken to public forums this year to literally beg companies to mine more of the stuff for his Tesla car company, and has entered talks with Vale, BHP and the Indonesian government. As a result, demand for nickel – currently just over 2 million t/a – is forecast to increase rapidly this decade. Some projections suggest demand for nickel could more than double by 2040. There are shortages projected as soon as 2023 due to a lack of new projects in the pipeline. On October 16th, Glencore’s CEO Ivan Glasenberg said that his company intends on “running down its coal mines” to reduce carbon emissions, and that it will use the funds freed up to invest instead in minerals such as copper, cobalt and especially nickel for energy transition markets and electric vehicles.

The upshot is that nickel projects, particularly HPAL-based, are all the rage again. This year First Quantum has re-started its Ravensthorpe HPAL plant in Australia, which it had bought off BHP when the latter decided to get out of HPAL, but which it too had not been able to operate profitably and closed down in 2017. Indonesia now has no fewer than six HPAL projects on the go, some backed by major Chinese investors like Tsingshan and Ningbo Lygend. Indonesian demand for acid for nickel production could reach 3 million t/a over the next few years. There are also expansions in the Philippines and Australia, and even Brazil.

But the technical challenges of HPAL have not gone away, as Vale could tell you. Its Goro nickel HPAL project on New Caledonia has been a problem child for the company, starting two years late in 2010, suffering a number of operational issues and incurring a \$1.6 billion write-down. This year it is expected to produce at only 40% of its notional capacity, an attempted sale to Australia’s New Century Resources has fallen through, and Vale has now decided to close the operation down. Sherritt might have something to say about HPAL as well. It exited the loss-making Ambatovy project on Madagascar this year, as did Korea Resources, while the third partner, Sumitomo, took a \$770 million write-down. China Metallurgical Group’s Ramu HPAL operation on Papua New Guinea, meanwhile, has been sued by local citizens for its waste dumping.

But HPAL can also be done well, as Sherritt has proved on Cuba, and Sumitomo in the Philippines. And coupled with the cobalt that the projects are also likely to unlock – equally in demand for batteries – the economics for HPAL are certainly looking better, as nickel becomes a two-tier market, with higher prices achievable for high purity grades. While there will undoubtedly be problems for some of the new projects, this is looking like gradually becoming a major slice of new sulphur and sulphuric acid demand over the next few years.

Richard Hands, Editor



“The technical challenges of HPAL have not gone away.”



End-to-end systems from receipt of molten sulphur to loading of solid material - single source supply by IPCO.

- High capacity liquid sulphur degassing
- Large scale block pouring and high capacity melting solutions
- Premium Rotoform pastillation and high capacity drum granulation
- Downstream storage - silo and open/closed stockpiles
- Custom built reclaimers for any location
- Truck, rail and ship loading and bagging systems

[ipco.com/sulphur](http://ipco.com/sulphur)



CONTENTS

What’s in issue 391

COVER FEATURE 1

Long term oil and gas output

COVER FEATURE 2

The market for sulphuric acid

COVER FEATURE 3

SRU oxygen enrichment

COVER FEATURE 4

Materials for sulphuric acid service

SULPHUR  
ISSUE 391  
NOVEMBER-DECEMBER 2020

BCInsight

Southbank House, Black Prince Road  
London SE1 7SJ, England  
Tel: +44 (0)20 7793 2567  
Fax: +44 (0)20 7793 2577  
Web: [www.bcinsight.com](http://www.bcinsight.com)  
[www.bcinsightsearch.com](http://www.bcinsightsearch.com)



**MARKET INSIGHT**

**Matt Langworthy**, Analyst for Argus Media, assesses price trends and the market outlook for sulphur.

**SULPHUR**

As we approach the end of the year, we have seen fourth quarter sulphur contract prices firm. Contract settlements followed a rally in spot prices towards the end of the third quarter as supply tightens heading into winter. The ongoing pandemic has only exacerbated this tightening as run-rate cuts at refineries, mainly to the west of the Suez, restricts sulphur output. And because of these cuts, supply has been particularly tight in North America, India, the Mediterranean and Western Europe. Many of these regions are now experiencing a second wave of coronavirus infections and re-entering lockdowns, so industry slowdowns and production cuts are expected to persist into early next year. But many consumers have now secured product for the year, leaving little demand in the market for the remainder of 2020, which will leave liquidity thin and lessen the influence of tight supply on pricing.

Middle East fourth quarter contracts have followed the slight increase seen elsewhere. And in the spot market, little availability is expected with product from the region prioritised for contracts, although spot activity is expected to continue the rise seen towards the end of the third quarter as some key off-takers have reduced their deliveries. Yet, with low levels of prompt demand as the year comes to a close, Middle East f.o.b. prices will soften.

After weeks of stagnation in the Chinese import market, we have seen granular prices firm a little to \$92-95/t c.fr as demand from the phosphate market remains strong. But as expected, southern Chinese consumers have favoured discounted Iranian shipments, not typically included in price assessments. One buyer reportedly took delivery of 31,000 t of granular product from Bandar Iman Khomeini which settled in the mid-\$80s/t c.fr China. In the Chinese molten sulphur market, 2021 supply contract negotiations have begun but in the spot market supply has held tight keeping prices firm at around \$60/t c.fr. Import quantities have been low this year as refineries faced production cuts. South Korea's capacity additions were expected to boost Chinese

imports of molten product, however operating rates across South Korean refineries remained low amid strict lockdowns and poor refining margins globally.

China's sulphur inventories rose to over 3.0 million tonnes at the start of the year as domestic consumers shut down as coronavirus lockdowns took hold across the country. Consumers in the country swiftly recovered into the second-half of the year, but port inventories remained high and were at 2.9 million tonnes at the end of October, up 38% over the same period as in 2019. And because of the influence of the pandemic and high inventory levels, as expected, imports have fallen 23% to 6.6 million tonnes in the first three quarters of this year relative to the same period in 2019. This reduction in imports has set the trend for the long-term trade outlook in China especially as investment into the refining sector across the country will increase sulphur capacity by around 45% as just under 5.0 million tonnes of oil-based sulphur capacity comes online by 2024. As domestic supply increases, and demand growth in the region is expected to remain limited, import volumes are expected to drop below 9.0 million tonnes/a within the next three years. Import volumes at this level have not been seen since the late 2000s. China is forecast to lose its spot as the leading global importer of sulphur in 2022, particularly as Moroccan fertilizer producer OCP's phosphate operations ramp up sulphur import demand.

In North America, prices have held steady as supply remains tight. Vancouver export prices rallied slightly heading into the start of November, increasing to \$66-73/t f.o.b. as demand continues to recover in Asia. But, supply tightness is expected to ease as Heartland Sulphur begins moving new granulated sulphur from its expanded capacity at their Fort Saskatchewan terminal. At the end of October, Heartland successfully began operating its second 2,000 t/d forming unit, doubling forming capacity at the terminal. The terminal now has an estimated forming capacity of 1.4 million t/a.

This is the first of four new Canadian forming projects in the pipeline. Keyera and Enbridge plan to bring 4,400 t/d of form-

ing capacity online at the existing South Cheecham Terminal in 2022, although production has yet to commence. Just a few kilometres to the north-west of South Cheecham, H.J. Baker Sulphur Canada is also planning a 4,000 t/d former. The latter was originally slated for start-up in the fourth quarter of this year but we have yet to see any project updates. Lastly, Sulphur Midstream is planning a 2,000 t/d former in Edmonton. Few details are known about the plant and we consider it to be speculative at this time.

Increased forming capacity will likely see Vancouver exports rise in the mid-term although molten exports to the US are expected to hold firm whilst demand remains strong and pricing attractive. Inventories in the US have been depleted as Covid-19 related refinery production cuts have contracted sulphur output. According to USGS data, sulphur production from January to August this year fell 350,000 t on the same period in 2019, corresponding to 6% reduction. Whilst higher production cuts were expected based on the decline in refinery utilisation rates, the increased use of imported heavy Saudi crude feedstock this year has mitigated some of the decline in production this year.

Fourth quarter prices in the US settled slightly up on the previous quarter, although very little, if any product is expected to ship. US Gulf export prices are remaining steady at \$62-73/t as spot market activity remains very limited. Further refinery production cuts from Hurricane Laura in August compounded tight supply already present from the coronavirus pandemic. But, as capacity begins to be reintroduced to the market, we are expecting export volumes from the Gulf to increase towards the end of the year. Citgo had been operating its 425,000 bbl/d refinery in Lake Charles at a reduced rate since it sustained damage from the hurricane but confirmed at the end of October normal operating rates have resumed.

New sulphur capacity in North America is limited to CNRL's oil sands expansions at Horizon in Canada. The expansion is expected to complete next year, increasing Horizon's capacity by 280,000 t/a since works began in 2015. Despite this, North American production is anticipated to decline in the long-term as Canadian gas reserves dwindle and US production is forecast to remain stable. Also, the country's tendency to favour sweeter crudes in recent years is expected to continue.

Already, this shift to lower sulphur-containing feedstock has seen sulphur production fall to 66% of oil-based capacity over the past five years – a level expected to hold steady into the long-term. At the time of writing, the results of the US election were uncertain, but a Biden administration could likely impact future production with the potential incumbent less supportive of the oil and gas sector.

**SULPHURIC ACID**

The East/West price divide which peaked early this year is still present with export prices in north-east Asia remaining in negative territory. Ample supply from Asian markets and demand still dampened by the coronavirus has slowed a price recovery in the region. But northwest Europe prices firmed quicker and climbed back into positive territory as we entered the third quarter. Fourth quarter contracts are progressing although sentiment from the industrial demand-side remains uncertain with ongoing lockdown restrictions.

In Morocco, OCP suspended berthing operations at Jorf Lasfar at the end of October as bad weather moved into the region but the fertilizer producer is expected to increase acid imports by just under 9% this year. OCP typically produces most of its sulphuric acid requirements from sulphur burners, however it has been and will continue to capitalise on cheap acid imports. Looking further ahead, Moroccan sulphuric acid demand is expected to grow

46% from 2019 to 2025 but imports are expected to hold steady over this period at around 1.6 million t/a – slightly under the 1.7 million t/a of imports we expect this year. Much of the demand growth will be met by increased sulphur burner capacity. With no domestic sulphur production, OCP relies entirely on the import market for its sulphur needs.

Indian demand is continuing to increase as phosphate fertilizer producers seek tonnes. Vedanta's ongoing battle with the Tamil Nadu state to restart their Tuticorin smelter continues to place uncertainty on the long-term acid outlook for the country especially as with years of no maintenance, a restart is beginning to look less certain. Vedanta appears to be exploring alternative options with plans to construct a new zinc smelter in Gujarat. Few details are known at this time but a post-2022 start-up is most likely considering the early stage of the project.

In China, export prices are remaining firm in the negative \$8/t to negative \$1/t f.o.b. range. Sellers are targeting positive f.o.b. prices although these remain well above workable c.fr prices. Netbacks from the domestic market are proving to be favourable with prices steadily rising over the past few weeks. Prices in Guizhou rose to Rmb 260-300/t delivered whilst prices remained steady at Rmb 310-340/t delivered in Yunnan. In the first nine months of the year, acid exports from China have fallen 12% to 1.4 million tonnes on the year. This fall came after the semi-withdrawal of the

2.3 million t/a capacity Two Lions burner in Zhangjiagang and a major decrease in demand from Chile as the copper industry contracted. We expect total acid production in China to decline to 93.7 million tonnes this year – a 2.9 million t/a drop on 2019. With a major portion of this loss attributed to burner capacity, smelter-based capacity is expected to become the leading source of acid production this year. Looking ahead, Chinese acid production will increase as new smelter projects come online. Notable additions include Houman North Copper in Shanzi which will enter production in 2023, adding 1.3 million t/a of capacity.

Prices in Chile have recovered from their lows in June to rise to \$40/t c.fr on a spot basis in recent weeks. Talk of annual contracts settling in the mid-\$50s/t c.fr is the current market sentiment but prices above and below this are also possible.

In Australia, First Quantum's Ravensthorpe nickel mine continues to operate after a successful restart earlier this year. The associated HPAL plant consumes acid produced from an onsite burner. Nickel-based demand across the Asia-Pacific region is expected to rise with several new HPAL projects due to come online in Indonesia. The series of new projects come as nickel demand from the battery sector is expected to surge over the next decade. We expect 2.3 million t/a of new nickel-based consumption from Indonesia by 2024 – the majority of which will be met by burner capacity as opposed to acid imports.

## Price Indications

Table 1: Recent sulphur prices, major markets

Cash equivalent	May	June	July	August	September
<b>Sulphur, bulk (\$/t)</b>					
Adnoc monthly contract	56	58	59	58	77
China c.fr spot	74	84	78	57	93
<b>Liquid sulphur (\$/t)</b>					
Tampa f.o.b. contract	54	54	58	58	58
NW Europe c.fr	84	98	98	98	107
<b>Sulphuric acid (\$/t)</b>					
US Gulf spot	40	40	43	45	50

Source: various

**CONTENTS**

What's in issue 391

**COVER FEATURE 1**

Long term oil and gas output

**COVER FEATURE 2**

The market for sulphuric acid

**COVER FEATURE 3**

SRU oxygen enrichment

**COVER FEATURE 4**

Materials for sulphuric acid service

SULPHUR  
**ISSUE 391**  
NOVEMBER-DECEMBER 2020

**BCInsight**

Southbank House, Black Prince Road  
London SE1 7SJ, England  
Tel: +44 (0)20 7793 2567  
Fax: +44 (0)20 7793 2577  
Web: www.bcinsight.com  
www.bcinsightsearch.com



# Market Outlook

Historical price trends \$/tonne

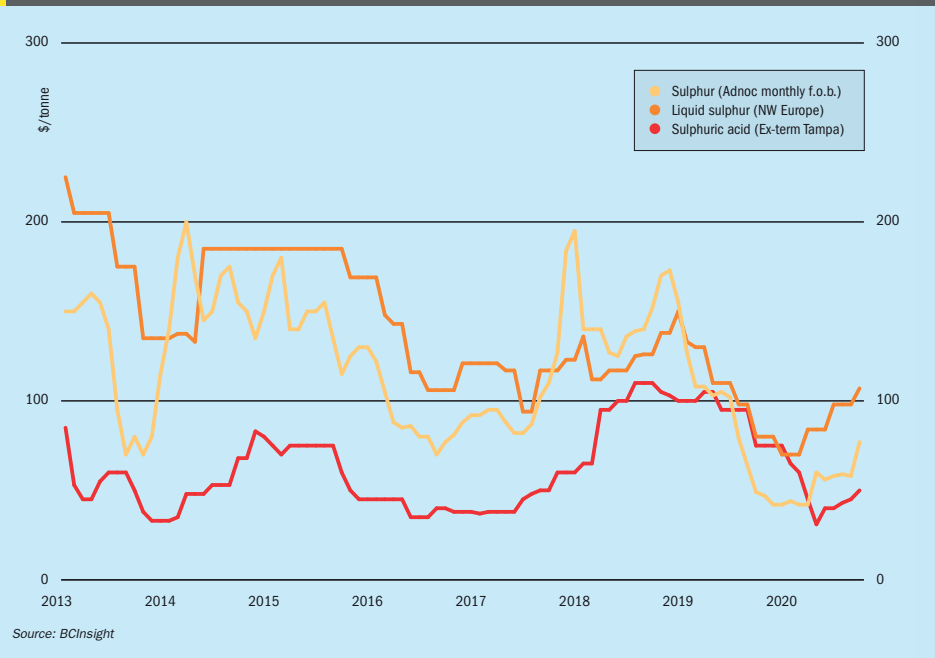

Source: BCInsight

## SULPHUR

- Production cuts globally at refineries have left supply tight heading into the fourth quarter, firming prices. This has been compounded by major exporters in the Middle East prioritising sulphur tonnes to contracts before spot sales.
- Chinese sulphur imports are expected to decrease as domestic capacity increases in the mid to long-term. Morocco is expected to become the leading global importer of sulphur by 2022 as OCP's phosphates industry continues to grow.
- Uncertainty surrounding the recovery of utilisation rates at refineries remains as countries globally re-enter lockdowns and a second wave of coronavirus infections spread.
- New Canadian forming capacity will increase the country's export flexibility and we may see increased exports from Vancouver in the mid to long-term.
- New capacity growth will come primarily from the Middle East. The region is expected to add 5.1 million t/a of sulphur capacity by 2025 on 2019 figures.

phur capacity by 2025 on 2019 figures.

- **Outlook:** Limited supply and strong demand from the phosphate market have seen buyers accept higher contract prices on the last quarter. Prices will likely peak this month before softening slightly into December and prices will remain stable heading into 2021 whilst supply remains tight.

## SULPHURIC ACID

- India's demand from fertilizer-based production remains firm with buyers on both coasts opening demand for November-December shipments.
- Firm sulphur prices and limited availability on the spot market heading into the fourth quarter, combined with historically low acid prices has led to fertilizer producers with flexible production lines shifting to acid imports over onsite acid production. Indian acid imports are expected to reach record-breaking levels by the end of the year.
- Uncertainty remains over India's long-term sulphuric acid supply as Vedanta's Tuticorin smelter remains shut.

- The copper industry in Chile is continuing to recover, increasing acid demand from the region as we move towards the end of the year. Annual contract discussions continue with bid/offer levels narrowing.
- Looking into the long-term, new nickel demand from the battery sector is expected to be a main driver for acid demand in Asia.
- **Outlook:** Pricing is expected to hold firm as demand sectors continue to recover from the coronavirus pandemic. Uncertainty surrounding logistics is growing in Europe as countries enter second lockdowns, however it seems restrictions will be less damaging than earlier in the year as governments attempt to minimise economic damage. The expected continuation of high sulphur prices and a strong phosphates market will support acid trade and prices. Looking further ahead, new smelter capacity in 2021 will limit price increases into next year. But a tightening of the market balance from 2022 out supports the view for price gains.

www.sulphurmagnitude.com

Sulphur 391 | November-December 2020

**HUGO PETERSEN**  
ENGINEERING IS OUR PASSION  
Your partner when it comes to sulphuric acid.

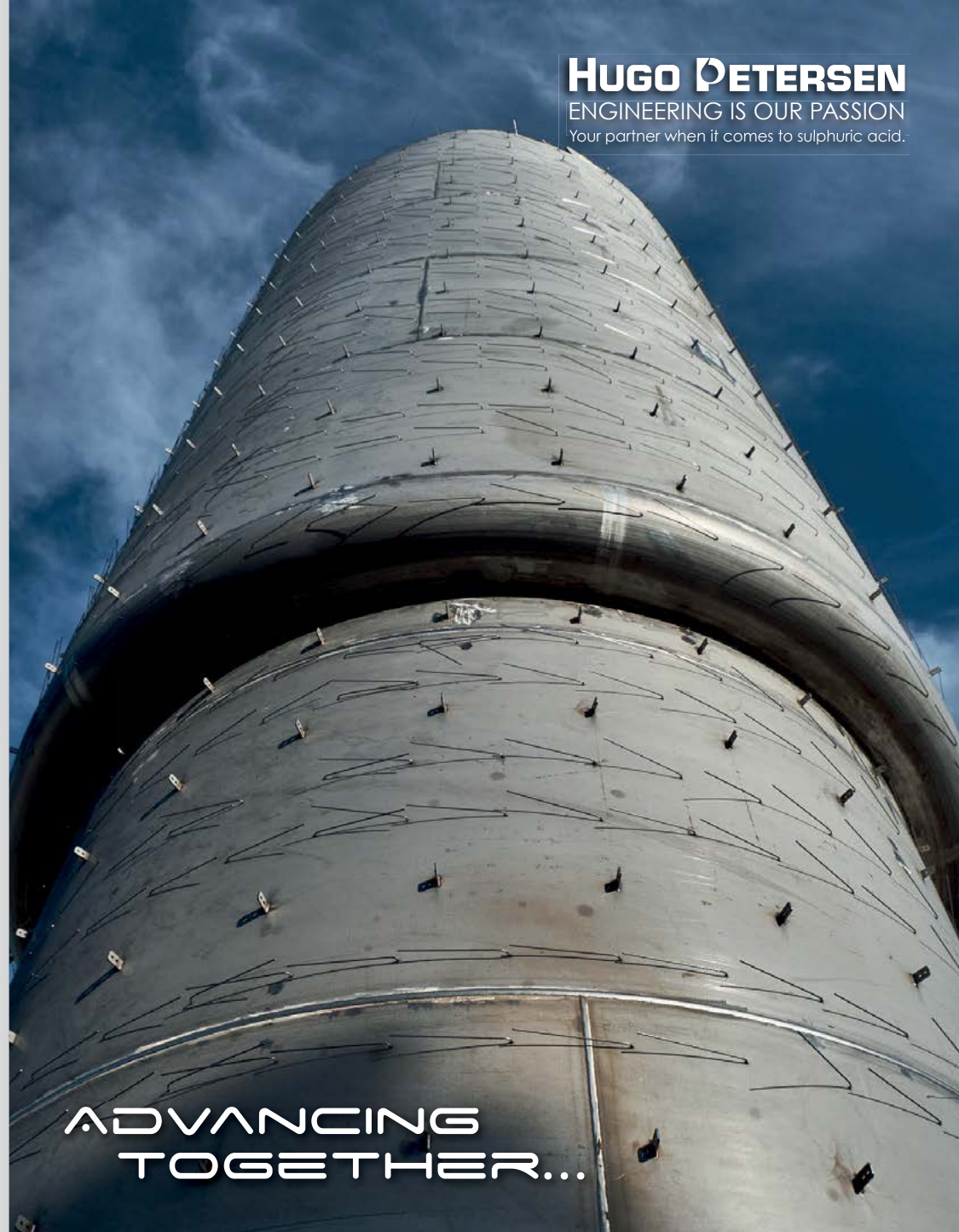

ADVANCING  
TOGETHER...



HUGO PETERSEN GmbH  
Rheingastrasse 190-196  
65203 Wiesbaden

Tel. +49 (611) 962-7820  
Fax +49 (611) 962-9099  
contact@hugo-petersen.de

WWW.HUGO-PETERSEN.DE

A subsidiary of



Chemieanlagenbau Chemnitz GmbH

CONTENTS

What's in issue 391

COVER FEATURE 1

Long term oil and gas output

COVER FEATURE 2

The market for sulphuric acid

COVER FEATURE 3

SRU oxygen enrichment

COVER FEATURE 4

Materials for sulphuric acid service

SULPHUR  
ISSUE 391  
NOVEMBER-DECEMBER 2020

BCInsight

Southbank House, Black Prince Road  
London SE1 7SJ, England

Tel: +44 (0)20 7793 2567

Fax: +44 (0)20 7793 2577

Web: www.bcinsight.com

www.bcinsightsearch.com

## UNITED STATES

### Brimstone STS and SRE announce strategic alliance

Brimstone STS Ltd. today announced a new partnership with Sulphur Recovery Engineering Inc (SRE). The two companies say that this collaboration will bring together decades of experience and the latest technology in support of the sulphur recovery and gas treating industry worldwide.

Based in Colorado, USA, Brimstone STS offers specialised services and products for field testing and evaluation of sulphur-related processes in the refining, gas processing, and chemical industries. It also provides expert training and runs its successful Vail Sulphur Recovery Symposium every September, which covers new and existing technologies along with products and services for operation of amine, Claus sulphur recovery, and tail gas treating processes.

SRE is an international engineering field testing and consult-

ing company that helps clients optimise performance of their sulphur recovery units and associated upstream process units. It has also collaborated with Virtual Materials Group, the developer of Symmetry™, a hydrocarbon simulation package that includes an SRU sulphur plant simulation package, to model plants that it visits for on-site optimisation.

"Our two companies complement each other very well and the result of this collaboration is a larger, stronger organization that can provide an even wider array of services throughout the world," says Mike Anderson, President at Brimstone.

"We're excited about the expanded capabilities and access to decades of information and experience our existing clients will gain from our partnership," says Don Green, Director at Sulphur Recovery Engineering.

### Catalyst plant awarded certificate of excellence

The DuPont Clean Technologies Avon plant in Martinez, California, has been awarded the American Chemistry Council's Responsible Care Certificate of Excellence in recognition of its prevention of occupational injuries and illnesses in 2019. The site manufactures MECS® catalyst for the sulphuric acid industry, which has been in production at this site since 1970. DuPont recorded zero fatalities, zero days away from work cases, and zero job transfer or restriction cases at the plant last year for both employees and contractors.

## NETHERLANDS

### Scrubbers have lower climate impact than low-sulphur fuel

A recent report from research and consultancy organisation CE Delft says that the environmental impact of exhaust gas cleaning (EGC) systems on ships will be less than that of low-sulphur marine fuel. It notes that CO<sub>2</sub> emissions associated with producing and installing an EGC system are small compared to those generated when operating the system. The CO<sub>2</sub> emissions are mainly related to the energy demand of the system's pumps, which typically result in a total increase in CO<sub>2</sub> emissions of between 1.5 and 3 percent.

By contrast, it says with desulphurised fuels the overall CO<sub>2</sub> footprint increase is a result of the refining processes. Theoretical calculations range from an increase in CO<sub>2</sub> emissions of 1% to as much as 25% when removing the sulphur content of the fuel.

The report states that while the lower figure is not in fact physically possible, the higher percentage increase is applicable only to a quality of fuel that is too high for marine applications. The conclusion, therefore, is that the CO<sub>2</sub> emissions associated with the production of low-sulphur marine fuels will be between these extreme values.

"This study provides a comprehensive overview of the climate impacts of different options to reduce sulphur emissions. It shows that in many cases, the carbon footprint of using a scrubber is lower than low-sulphur fuels," said Jasper Faber, Project Manager at CE Delft.

Research has indicated that greenhouse gas (GHG) emissions from shipping have increased by more than 10% in the last five years. These emissions are projected to increase by up to 50% by 2050, which means that if the International Maritime Organization's goal to significantly lower the industry's GHG emissions is to be achieved, scrutiny of all aspects of shipping is necessary.

## RUSSIA

### Gazpromneft installs wet scrubbing technology

The Gazpromneft Omsk refinery in Siberia has installed BELCO® wet scrubbing technology licensed by DuPont Clean Technologies as part of a fluidised catalytic cracking unit (FCCU) revamp in order to remove process impurities from the flue gas emitted by the FCCU, reducing air emissions well below detection limits. The wet scrubber was an important part of a large-scale modernisation project that Gazpromneft began at the

Omsk refinery in 2008. One of the aims of the project was to systematically introduce technologies that reduce the refinery's environmental impact. DuPont says that the BELCO technology design also allowed the Omsk Oil Refinery to solve a challenging installation and plot space problem for the gas cleaning section. Thanks to the scrubber design, which is contained in a single upflow tower, the refinery was able to simply dismantle a pre-existing 70m tall, brick flue stack and install the scrubber on the previous chimney foundations.

The scrubber uses a proprietary design consisting of a water spray tower equipped with a filtering module and droplet separators. Larger particulates and SO<sub>2</sub> are removed in the spray tower, and fine particulate is removed in the filtering module section, so that only cleaned flue gas leaves the tower. The process is fully automated, and the system comes with built-in control analysers that allow for constant online monitoring.

"The Omsk Refinery was one of the first refineries in Russia to use this state-of-the-art fluid catalytic cracking regenerator flue gas cleaning technology. This is an exclusively environmental protection project that supports our high standards of environmental safety," said Oleg Belyavsky, General Director of the Omsk Refinery.

### Nornickel presents SO<sub>2</sub> remediation programme

Norilsk Nickel (Nornickel) has presented a comprehensive \$1.15 billion five year upgrade programme on its copper refining operations at its Monchegorsk site south of Murmansk. Chief operating officer COO



## Clean Technologies



# Making everyday life better, safer, cleaner

For 100 years, we have partnered sulfuric acid producers with innovative technology and expert trouble-shooting technical support. And our tradition of designing advanced solutions to solve site-specific challenges continues – so we can together deliver cleaner air productively, efficiently and reliably.

Learn more on [www.cleantechnologies.dupont.com](http://www.cleantechnologies.dupont.com)

## MECS®

Sulphuric acid & environmental technologies



Copyright © 2019 DuPont. The DuPont Oval Logo, DuPont™, is registered trademarks or trademarks of E.I. du Pont de Nemours and Company or its affiliates. All rights reserved.

CONTENTS

What's in issue 391

COVER FEATURE 1

Long term oil and gas output

COVER FEATURE 2

The market for sulphuric acid

COVER FEATURE 3

SRU oxygen enrichment

COVER FEATURE 4

Materials for sulphuric acid service

SULPHUR  
ISSUE 391  
NOVEMBER-DECEMBER 2020

# BCInsight

Southbank House, Black Prince Road  
London SE1 7SJ, England  
Tel: +44 (0)20 7793 2567  
Fax: +44 (0)20 7793 2577  
Web: [www.bcinsight.com](http://www.bcinsight.com)  
[www.bcinsightsearch.com](http://www.bcinsightsearch.com)



Sergey Dyachenko and vice president and head of Nor Nickel's Kola division Evgeny Borzenko presented the upgrade programme to Andrey Chibis, Governor of the Murmansk Region. The project is a part of the company's strategy to revamp and replace obsolete and polluting technologies and reduce its emissions of sulphur dioxide. The company's strategic goal is to reduce SO<sub>2</sub> emissions at both of its Kola Peninsula sites by 85% in 2021 compared to 2015, when emissions totalled 155,000 t/a.

As a part of the upgrade programme, the nickel refinery at the Kola Mining and Metallurgical Company (Kola MMC, a subsidiary of Nor Nickel) will undergo a major revamp, which will help minimise the facility's environmental footprint. New copper production will start on the Kola Peninsula in 2025. Nor Nickel intends to increase copper output from 75,000 t/a to 200,000 t/a, making the Monchegorsk site one of Nor Nickel's largest copper refining facilities.

Nor Nickel has come under pressure from the Finnish government to deal with SO<sub>2</sub> emissions on the Kola Peninsula. It has also faced criticism in Russia after melting permafrost led to a large diesel spill at its Nadezhda plant at Norilsk in western Siberia earlier in the year. The Nadezhda plant is the largest single emitter of SO<sub>2</sub> in the world, and as part of its remediation programme, Nor Nickel has begun its Sulphur Project in conjunction with Russian construction and engineering company STEP. The project aims to reduce SO<sub>2</sub> emissions at the site by 45% and increase SO<sub>2</sub> recovery to 99% by 2022. The SO<sub>2</sub> will be captured and made into acid which will then be neutralised with natural limestone to form gypsum.

"Shutting down and upgrading outdated production facilities while also building new production is vital both for the company's efficiency and its sustainable development," said Evgeny Borzenko, VP and head of Nor Nickel's Kola Division. "The programme places great importance on the environment. By upgrading copper refining facilities in Monchegorsk, we will enhance the positions of Kola Division and Nor Nickel as a whole in copper production. This will also be a solution to curb air emissions generated by the metallurgical plant. I cannot emphasise enough just how important this project is."

#### MIDDLE EAST

### Gas mega-projects face major risks

In a new report, the Arab Petroleum Investment Corporation (Apicorp), the investment

fund of the Organisation of Arab Petroleum Exporting Countries (OPEC), says that the ongoing oil market crisis and Covid issues have not so far had a detrimental effect on sour gas investments in the Middle East and North Africa. Apicorp reports that overall gas investments have been steady in 2020 compared to 2019, with planned investments showing an increase of 29% to reach \$126 billion. The main driver for the current increase in investment is a regional drive for cleaner power generation and the use of natural gas and condensates as a feedstock for the petrochemical industry.

However, Apicorp says that globally gas demand has been hit by Covid-19 and associated lockdowns and recession, and has decreased by 4%, with Asia, the US, and Europe the most affected continents. This has put fiscal pressure on government and private sectors alike, and Apicorp says it expects a few committed projects to continue facing strong headwinds in terms of payments, supply chain issues, and potential project delays. Low and volatile oil prices also pose risks for regional gas investments.

Major regional gas players such as Saudi Arabia, Iraq, and Iran are still committed to their respective gas investments. The UAE also is committed to its \$22 billion gas development masterplan, which includes unconventional and sour gas projects. Qatar's huge \$22 billion planned investment is still on the table, but some question the viability and commercial attractiveness of Doha's LNG expansion in the light of a global LNG glut. Apicorp expects that other regional national oil companies will take the same route as ADNOC, which sold a minority stake in its gas pipeline assets for \$20.7 billion to international investors.

#### CANADA

### Keyera commissions Pipestone gas plant

Keyera Corp. says that it has started up its Pipestone sour gas processing and liquids stabilisation plant located west of Grande Prairie, Alberta. The plant has been a joint effort with Ovitiv Inc. (formerly Encana Corp.) to support Keyera's condensate-focused Pipestone Montney development. The 200 million scf/d gas plant, which also features 24,000 bbl/d of condensate processing and associated water disposal installations, as well as acid gas reinjection capability, entered operation five months ahead of its original

schedule and at budgeted costs on October 13th, Keyera said.

"This project aligns with Keyera's strategy of building a stronger presence in the liquids-rich Montney development, which is one of the most economic developments in the Western Canada Sedimentary Basin," said David Smith, Keyera's chief executive officer. "With our Pipestone, Wapiti and Simonette gas plants, Keyera has infrastructure in the area providing 950 million cubic feet per day of gas processing capacity and 90,000 barrels per day of condensate processing capacity. In the future, this capacity will be connected to our KAPS natural gas liquids and condensate pipeline that we expect to have in service in 2023. We look forward to continuing to work with Ovitiv to support their important development in a safe and environmentally responsible manner."

#### NIGERIA

### Axens selected for BUA refinery project

Nigeria's food, mining, manufacturing and infrastructure company BUA Group has awarded Axens a contract for the supply of process technologies for BUA's new 200,000 bbl/d greenfield refinery and associated petrochemicals facility in Nigeria. The integrated project aims at producing Euro-V fuels and polypropylene for the domestic and regional market. Axens will provide advanced technology licenses, basic engineering, catalysts and adsorbents, proprietary equipment, training and technical services.

#### GERMANY

### Evonik buys Porocel Group

Evonik Industries AG has announced that it has entered into a definitive agreement to acquire the Porocel Group for \$210 million to accelerate the growth of its catalysts business. Based in Houston, Texas, Porocel offers a technology for rejuvenation of desulphurisation catalysts, which are in increasing demand to produce low-sulphur fuel. Rejuvenation reduces carbon dioxide emissions by more than 50% compared with the production of new catalysts, according to Porocel. Porocel also has spare production capacity, enabling Evonik to speed up expansion of its existing business with fixed bed catalysts.

"This acquisition is the next logical step in the strategic development of our portfolio. Our focus is on stable and high-margin specialty chemicals," said Christian

Kullmann, chairman of Evonik's executive board. "We are systematically expanding the share of our specialty businesses – and that at an attractive valuation."

#### IRAN

### South Pars phase 12 producing 260 t/d of sulphur

Phase 12 of Iran's South Pars gas field – its largest – has produced 14 billion cubic meters of gas during the first six months of the current Iranian calendar year (March-September), according to the operating company. Speaking to Iranian media, plant director Mohammad-Mehdi Hashemi said that the refinery had also produced more than 47,200 tonnes of sulphur over that period. According to Hashemi, the annual maintenance operations on the gas processing plant have been completed despite complications created by the coronavirus outbreak, and it is ready to operate at full capacity during the cold season. The gas plant receives 46 million m<sup>3</sup>/d of gas from South Pars phases 22-24 and produces over 40 million m<sup>3</sup>/d of sweet gas, as well as 260 t/d of sulphur.

#### BELARUS

### Sulphur plant at Mozyr near completion

According to local press reports, construction and installation work on a new sulphur plant at the Mozyr refinery's new heavy oil hydrocracking complex are approaching completion. Off-site utilities are complete and a hydrogen plant which forms part of the \$1.2 billion complex is almost ready for commissioning. The sulphur unit is reported to be 99% complete, and the hydrocracking unit itself 80% complete, with construction and installation work in progress and hydrostatic pipeline testing under way.

#### CHINA

### Sinopec starts up alkylation unit

Sinopec Qilu's refinery in Zibo, Shandong province has successfully started up a new alkylation unit. The DuPont Clean Technologies-designed STRATCO<sup>®</sup> alkylation unit will produce 400,000 t/a of alkylate product from an MTBE raffinate feedstock and will enable the production of low-sulphur, high-octane alkylate with zero olefins that meets the China V standard.



## CHEMETICS<sup>®</sup>

### Radial Flow Stainless Steel Converters

#### Experience:

- Originally developed and patented by Chemetics in 1981
- Industry standard best in class design
- More than 50 designed, fabricated and supplied by Chemetics

#### Features and Benefits:

- Radial flow design
  - Uniform gas distribution results in optimal catalyst performance
- All welded, contoured separation and support elements
  - Eliminates gas bypassing
  - Low mechanical stress design uses up to 30% less stainless steel
- No "Posts and Grates" for ease of access and catalyst installation
- Round gas nozzles eliminates leaks, over 1000 years of leak free operation
- Modular construction options to reduce cost and schedule risk
- Flexible configurations, such as internal heat exchangers, for easy retrofits.

#### Innovative solutions for your Sulphuric Acid Plant needs

**Chemetics Inc.**  
(headquarters)  
Vancouver, British Columbia, Canada  
Tel: +1.604.734.1200 Fax: +1.604.734.0340  
email: chemetics.info@worley.com

[www.worley.com/chemetics](http://www.worley.com/chemetics)

**Chemetics Inc.**  
(fabrication facility)  
Pickering, Ontario, Canada  
Tel: +1.905.619.5200 Fax: +1.905.619.5345  
email: chemetics.equipment@worley.com

Chemetics Inc., a Worley company

#### CONTENTS

What's in issue 391

#### COVER FEATURE 1

Long term oil and gas output

#### COVER FEATURE 2

The market for sulphuric acid

#### COVER FEATURE 3

SRU oxygen enrichment

#### COVER FEATURE 4

Materials for sulphuric acid service

SULPHUR  
ISSUE 391  
NOVEMBER-DECEMBER 2020

BCInsight

Southbank House, Black Prince Road  
London SE1 7SJ, England

Tel: +44 (0)20 7793 2567

Fax: +44 (0)20 7793 2577

Web: [www.bcinsight.com](http://www.bcinsight.com)  
[www.bcinsightsearch.com](http://www.bcinsightsearch.com)

## UNITED STATES

### Musk focuses on nickel at 'battery day'

In early October Tesla held a 'battery day' event at its headquarters in Fremont, California. Speaking at the event, company founder and CEO Elon Musk outlined his vision for the electric car industry over the coming decades, and spoke particularly to his ambitions for the nickel industry. He had already called for more mining of nickel earlier in the year, and has said that Tesla is developing cathodes that will contain higher nickel and no cobalt. The latter comes after a lawsuit against Tesla and several other high-tech US firms for allegedly supporting human rights violations by buying cobalt from the Democratic Republic of Congo. Musk echoed the potential 'reputational risk' for the nickel market and called for more sustainable nickel production, dangling the prospect of a "giant contract" with any miners that could produce nickel in an "environmentally sensitive way." Tesla is reportedly in discussions with Vale and BHP as well as the Indonesian government concerning potential investments in nickel production.

BHP has said that it is committed to a 30% reduction in its carbon emissions by 2030 and plans to implement these changes by securing renewable power contracts for its operations, installing steam generators and solar power across its nickel operations, as well as removing 100% of SO<sub>2</sub> emissions at its Nickel West operations at Kalgoorlie by 2024 and converting them to sulphuric acid.

Glenore has also indicated that it is in talks with car manufacturers and battery makers about nickel. The company already supplies BMW with cobalt from its Murrin Murrin nickel-cobalt mine in Australia. ■

## BRAZIL

### US investment in nickel leaching project

The US International Development Finance Corp (DFC) has made a \$25 million investment into TechMet Ltd, a private investment company with a portfolio of projects that produce, process and recycle metals tied to the production of electric vehicles (EVs), renewable energy systems and energy storage. The funds will be used to bring to commercial production one of TechMet's core investments, Brazilian Nickel Plc, which will be a low-cost nickel-cobalt producer in Piauí, in north-eastern Brazil, it said.

Piauí is a nickel laterite heap leaching project, aiming at an initial production of 10,000 t/a of nickel, potentially rising to 25,000 t/a, with first production beginning in 2022. Brazilian Nickel has previously completed a large-scale demonstration of the heap leaching, purification and recovery of nickel and cobalt from the Piauí ore. The investment will be aimed at producing nickel and cobalt for the electric vehicle market in the US.

Brian Menell, Chairman and CEO of TechMet, said: "We are very pleased to have secured this funding and support from DFC, which enables Brazilian Nickel Plc to begin the commercial production of

nickel and cobalt products used in the production of EV batteries. Having this level of US support is a great endorsement of TechMet's team and strategy."

Brazilian Nickel figures indicate that production of 10,000 t/a of nickel would consume around 400 kg of sulphuric acid per tonne of ore processed, or around 500,000 t/a of acid, which would probably be supplied via a sulphur burning plant.

### Jerois to buy nickel/cobalt leaching plant

Jerois Mining Ltd, a cobalt mining company with assets in Idaho, Uganda, and Australia, has said that it will acquire 100% of the Sao Miguel Paulista (SMP) nickel and cobalt refinery in Sao Paulo State from Companhia Brasileira de Alumínio, for \$22.5 million. The SMP Refinery has a production capacity of 25,000 t/a of refined nickel and 2,000 t/a of cobalt via a sulphuric acid leach and SX/EW recovery. The site was placed on care and maintenance in 2016.

Jerois says that it will use the SMP site to refine concentrate from its new Idaho operation, and return the cobalt metal to the United States. It will initially lease the site from Companhia Brasileira de Alumínio while a feasibility study is conducted on a restart, with a final closure on purchase expected – assuming all goes well – by December 2021. Jerois has outlined three potential operating scenarios so far;

either processing Idaho Cobalt Operations (ICO) concentrate only, producing 2,000 t/a of refined cobalt; processing ICO concentrate and cobalt hydroxide, generating: 8,000 t/a of refined cobalt; and a mixed hydroxide nickel/cobalt plan which would generate 10,000 t/a of refined nickel and 2,300 t/a of refined cobalt.

## INDONESIA

### New state battery firm will look to HPAL

Mining Industry Indonesia (MIND ID) chief executive Orlas Petrus Moedak says that Indonesia is assembling a new state-owned joint venture to make batteries for electric vehicles. Speaking to an industry webinar, Moedak said that the new venture, Indonesia Battery Holding, would be a joint venture between mining companies MIND ID and Aneka Tambang (ANTAM), utility company Perusahaan Listrik Negara (PLN) and state oil company Pertamina. The company would aim to cover the full production chain, from mining to producing chemicals and minerals for batteries to making the units themselves, as well as recycling old batteries, Orlas said. Reuters reports that Orlas has also indicated that state mining company ANTAM will also work on related projects including high-pressure acid leaching (HPAL) and rotary kiln electric furnace (RKEF) smelter projects valued at \$2–3 billion. Indonesia is already looking at up to six HPAL projects, with PT Halmahera Persada Lygend, PT Adhikara Cipta Mulia, PT Smelter Nikel Indonesia, PT Vale Indonesia, PT Huayue, and PT QMB all with projects under active development.

## CANADA

### Joint venture proposal for Blawn Mountain

SOPerrior Fertilizer Corp. says that it has signed a letter of intent with an unnamed other party to form a joint venture for the development of the 15,000 acre Blawn Mountain mining lease located in Utah, and the financing and construction of an alunite ore processing plant at the site. The ore will be processed to yield alumina, potassium sulphate ('sulphate of potash' or SOP) and sulphuric acid. For every tonne of SOP produced, approximately 2 tonnes of alumina and 2.15 tonnes of sulphuric acid are co-produced, according to the company. The project has permits to produce up to 645,000 t/a of SOP, which

would generate 1.4 million t/a of sulphuric acid, which SOPerrior says would be "used onsite in the processing of other valuable mineral deposits".

## AUSTRALIA

### BHP scraps Olympic Dam expansion

BHP has abandoned its proposed \$3.7 billion Brownfields Expansion at Olympic Dam in favour of a number of smaller projects to improve reliability and increase capacity. The project planned to increase copper output at Olympic Dam from 200,000 t/a to up to 300,000 t/a, as well as boosting gold, silver and uranium production. However, the results of a study into the expansion have found that copper resources in the Southern Mine Area are more structurally complex, and the higher-grade zones less continuous, than previously thought. The company says that it will instead focus on targeted debottlenecking investments, plant upgrades and modernisation of infrastructure to increase efficiency and production.

## DENMARK

### Topsoe to refocus its strategy

Haldor Topsoe is reorganising in order to pursue a new strategic direction. As part of its new focus, the company is aiming to be recognised as the global leader in carbon emission reduction technologies by 2024. It is also aiming to be more customer facing, with a strong commercial set-up, effective production, and innovation to deliver technologies demanded by the market.

"We have designed an organisation with a clear focus on accelerating the development of carbon-neutral technologies, and it will be funded by continued delivery of Topsoe's globally leading solutions for energy-efficient production of conventional fuels and chemicals," said Roeland Baan, CEO of Haldor Topsoe. "This transformation has a very strong foundation in our exceptional R&D capabilities, world-leading technologies, and a long standing dedication to making a positive difference in the world by perfecting chemistry.

Many employees will get new responsibilities as departments and business areas are refocused to deliver on the vision, which will also result in approximately 200 redundancies.

"It is never easy to let talented employees go. I want to thank them all for being part of making Topsoe a success," said

Baan. "With our new organization in place, I am confident that Topsoe has come closer to taking a decisive role globally. The world is at a climate crossroads, and Topsoe delivers technologies that target some of the most pressing challenges. Now, we have taken the first step on a very ambitious journey defined by our new vision, and we have what it takes to reach our goal."

The new organization will be effective from November 1st, 2020.

## RUSSIA

### PhosAgro reports increased sales and production

In its 3Q 2020 results presentation, PhosAgro, said that it had increased fertilizer sales by 10% in the nine months to September on the same period in 2019. Total fertilizer production increased by almost 5% to 7.5 million tonnes, due to the ongoing modernisation of production facilities and efficiency improvements achieved over the year.

Sulphuric acid production increased by 11.4% year on year to 5.1 million t/a to the end of September, due to the beginning of operations at a new 1.1 million t/a sulphuric acid production unit at Cherepovets, Russia, in the middle of 1Q20. Ammonium sulphate production at Cherepovets increased to its full capacity of 300,000 t/a.

Andrey Guryev, CEO of PhosArgo, said: "Despite some improvement in the epidemiological situation in the summer period, we have kept in place the comprehensive prevention measures that were introduced when the first signs of the pandemic appeared. As a result, in the face of a new wave of coronavirus infections in Russia and globally, PhosAgro is fully prepared to continue operating at full capacity, following effective protocols to protect its personnel and the residents of the regions of where it operates."

## WORLD

### Copper production to increase in 2021

The International Copper Study Group (ICSG) has released its copper market forecast for 2020-21 and says that 2020 will mark the second consecutive year of falling world copper mine production, with output dropping 1.5% in 2020 after a 0.2% fall in 2019. However, it forecasts that 2021 will see mined copper output

## CONTENTS

What's in issue 391

## COVER FEATURE 1

Long term oil and gas output

## COVER FEATURE 2

The market for sulphuric acid

## COVER FEATURE 3

SRU oxygen enrichment

## COVER FEATURE 4

Materials for sulphuric acid service

SULPHUR  
ISSUE 391  
NOVEMBER-DECEMBER 2020

# BCInsight

Southbank House, Black Prince Road  
London SE1 7SJ, England

Tel: +44 (0)20 7793 2567

Fax: +44 (0)20 7793 2577

Web: [www.bcinsight.com](http://www.bcinsight.com)  
[www.bcinsightsearch.com](http://www.bcinsightsearch.com)



# People

ClimateCo says that it has promoted Dr. **Scott Subler** to Chief Science Officer (CSO). Subler has made an enduring mark on the carbon offset world over the last 15 years. From overseeing the first US offset delivery from a dairy farm methane capture project to chairing the Offsets Committee for the Chicago Climate Exchange, Subler has been a major influence on many carbon offset methodologies that are used today. His work investigating different types of lagoon cover systems for dairy and swine farms in different climates continues to impact new methane capture installations, and his advocacy for organic waste composting projects resulted in the protocol used today at the Climate Action Reserve.

**Philip Eickhoff** has been appointed CFO of Haldor Topsoe. Prior to this appointment, Eickhoff was CFO of Atos Medical and before that Regional CFO of Coloplast North America. He has also served as Industrial Advisor to global private equity funds. He has a consulting background from Bain & Company.

"Philip has a commercial and strategic profile that will optimally support Haldor Topsoe's ongoing transformation based on the company's brand new vision and purpose. He brings significant experience in driving large-scale transformations and growth acceleration, and I am very happy that Philip will join our exciting journey," says Roeland Baan, CEO of Haldor Topsoe.

"I am truly excited to take on the position as CFO in Haldor Topsoe. The compa-



Philip Eickhoff.

ny's new vision to become recognised as the global leader in carbon emission reduction technologies by 2024 is both inspiring and ambitious. I look forward to contributing to the transformation and leveraging Topsoe's market leadership position towards more sustainable and energy-efficient solutions," says Philip Eickhoff.

The UK Agricultural Industries Confederation has announced that **Sam Bell**, UK Commercial Director at CF Industries and **Nick Major**, Corporate Affairs Director at ForFarmers have taken over as chairs for the AIC's Fertiliser Executive Committee and Feed Executive Committee, respectively.

Commenting on Sam's appointment, Jo Gilbertson, Fertiliser Sector head for the AIC said; "Sam's appointment comes at a critical time for the sector and we are delighted that she has accepted the role. I am confident that Sam will build on the excellent work that Peter Scott Technical Director Origin Fertilisers, has driven over the last two years. The sector will not be losing Peter's expertise as he has recently been appointed Chair of the European Fertiliser Blenders' Association (EFBA). Sam will be taking up her role on the 28th October".

CRU has appointed **Heidi Bryant** as Marketing Director. Heidi has over 26 years' experience in marketing, predominantly in blue chip financial services organisations such as HSBC, Barclays, BlackRock and Merrill Lynch. She is also an advocate of marketing automation and digital marketing technologies. She has built global marketing teams and strategies across the full marketing mix and has enabled companies like HSBC and iShares (BlackRock) to achieve multi-billion-dollar growth, responsible for enabling digital transformation projects, commercialising marketing activities and driving marketing qualified leads into businesses.

David Trafford, CEO, CRU Group said: "Heidi Bryant has all the necessary knowledge and experience to drive the continued growth of the company. I look forward to seeing the benefits that she brings to CRU and our global marketing effort."

## Calendar 2020/21

**!** The following events may be subject to postponement or cancellation due to the global coronavirus pandemic. Please check the status of individual events with organisers.

### NOVEMBER

17-18

European Refining Technology Conference – Virtual event  
Contact: Sandil Sanmugam, World Refining Association  
Tel: +44 20 7384 7744  
Email: sandil.sanmugam@wraconferences.com

24-25

European Sulphuric Acid Association Autumn General Assembly – Virtual event  
Contact: Francesca Ortolan, Cefic  
Tel: +32 2 436 95 09  
Email: for@cefic.be

### JANUARY 2021

Date T.B.A.

ASRL Chalk Talks, CALGARY, Canada  
Contact: Alberta Sulphur Research Ltd  
Tel: +1 403 220 5346  
E-mail: asrinfo@calgary.ca

### FEBRUARY

1-3

SulGas Conference – Virtual event  
Contact: Conference Communications Office  
Tel: +91 73308 75310  
Email: admin@sulgasconference.com

22-25

Laurance Reid Annual Gas Conditioning Conference – Virtual event  
Contact: Lily Martinez, Program Director  
Email: lmartinez@ou.edu  
Web: www.pacs.ou.edu/lrgcc/

### MARCH

1-5

Brimstone Fundamentals of Sulphur Recovery – Online training course  
Contact: Mike Anderson, Brimstone STS  
Phone: +1 909 597 3249  
Email: mike.anderson@brimstone-sts.com

7-9

AFPM Annual Meeting, SAN ANTONIO, Texas, USA  
Contact: American Fuel and Petrochemical Manufacturers (AFPM)  
Tel: +1 202 457 0480  
Email: meetings@afpm.org  
Web: www.afpm.org

22-26

Brimstone Advanced Sulphur Recovery – Online training course  
Contact: Mike Anderson, Brimstone STS  
Phone: +1 909 597 3249  
Email: mike.anderson@brimstone-sts.com

23-25

Phosphates 2021 Conference – Virtual event  
Contact: CRU Events  
Tel: +44 20 7903 2444  
Email: conferences@crugroup.com

# SulGas

VIRTUAL | 2021

Feb 1-3  
10 AM – 5 PM

**SOUTH ASIA'S ONLY CONFERENCE ON SULPHUR RECOVERY & GAS TREATING IS NOW VIRTUAL**

+91-77330875310  
@SulGasConf  
@SulGas Conference  
@SulGasConf  
admin@sulgasconference.com  
www.sulgasconference.com

Over the last 2 years, SulGas has established itself as a marquee event in South Asia devoted exclusively to various topics in the areas of Sulphur Recovery and Gas Treating. SulGas is distinguished as a neutral, and high-quality technical forum in the region.

Due to Covid-19, considering the safety of the participants and attendees, SulGas 2021 will be conducted as a virtual event.



### Technical Focus

Gas Processing Simulation & Optimization  
SRU Instrumentation & Monitoring  
Amine Hygiene, Emissions, Corrosion,  
Alternate to Claus Sulphur Processing

### Registration

Hear from global technical experts at the comfort of your home/office



### Stats that matter\*

200+

Attendees

\*anticipated

15+

Countries  
(India, Asia Pacific,  
Middle East)

70+

Participating  
Companies

15+

Operating  
Companies

30+

Manufacturing  
Sites

**Sponsorship options to maximize visibility (Executive sponsorship still open)**



Live speaking opportunities & Delegate passes  
Attendee analytics & Social media promotions  
Company information on website & promotional material



### Premier Sponsors



### Executive Sponsors



### Official Publication



### Media Partners



### Organizing Partners



Registration Fee  
Heavily Discounted Due to CoVID-19

Operating Companies - FREE Registration  
Others ₹30,000/USD 600 ₹6,000/USD 100 + GST

### CONTENTS

What's in issue 391

### COVER FEATURE 1

Long term oil and gas output

### COVER FEATURE 2

The market for sulphuric acid

### COVER FEATURE 3

SRU oxygen enrichment

### COVER FEATURE 4

Materials for sulphuric acid service

SULPHUR  
ISSUE 391  
NOVEMBER-DECEMBER 2020

BCInsight

Southbank House, Black Prince Road  
London SE1 7SJ, England  
Tel: +44 (0)20 7793 2567  
Fax: +44 (0)20 7793 2577  
Web: www.bcinsight.com  
www.bcinsightsearch.com



Demand for oil in developed countries was already falling before the coronavirus outbreak, and consumption growth is slowing in the developing world. Peak oil demand may arrive in the next decade. Coupled with more reinjection of sour gas rather than sulphur extraction, could we be seeing falling elemental sulphur production in a decade or so?

While the spread of the Covid virus has been a major public health crisis for all countries of the world, its economic effects are likely to be felt long beyond the time when the virus is – hopefully – brought under control. The effects on refinery production have already been profound, and they are likely to be part of a larger pattern of long term change in the oil and gas industries which could significantly affect the supply of sulphur in the medium and longer term.

Sulphur production is dependent primarily on recovery from crude oil at refineries, and from sour gas at processing plants. As involuntary production, sulphur supply is thus effectively dependent on global demand for refined products from refiners, and the need for natural gas, mainly for power generation. Oil demand has been falling in OECD countries for some time, due to ageing populations and greater fuel economy in vehicles, but now

environmental and other factors may also bring first a plateau and then a decline in demand in developing countries, leading to the time of 'peak oil demand'.

### Medium term – the pandemic

The Covid-19 pandemic has, in the words of the International Energy Agency's 2020 World Energy Outlook, "caused more disruption to the energy sector than any other event in recent history, leaving impacts that will be felt for years to come." Global energy demand will be down by about 5% on 2019, and global oil consumption down an unprecedented 9.5%.

The oil market has had its third price shock in 12 years, after the global financial crisis of 2008, and the price crash of 2014, the latter driven by a slowing Chinese economy, rising shale-based production and a higher dollar exchange rate. But while there was a sharp down-

ward correction in both cases, followed by a steady recovery, the lingering effects of Covid, including a second wave of infections across Europe, continue to make the recovery from this shock much more uncertain. Oil prices fell from \$70/bbl in January to less than \$20/bbl in April, and in spite of some recovery to \$45/bbl over the summer, they are finishing the year heading back down around \$35/bbl.

The questions for the medium term are firstly, how long will it take for the virus outbreak to finally be brought under some kind of control, and then, what will the lingering effects on our collective behaviour be? Will people return to flying as much as they did before the pandemic, or have we all got used to doing business over videoconferencing? Last year the IEA was predicting that aviation fuel demand would grow by 1% per annum over the next five years, much faster than gasoline demand, which would be virtually flat. Now however,

the International Air Transport Association estimates that traffic will remain 30-40% down on pre-Covid levels even if there is a vaccine. On the other hand, growth in home deliveries and a decline in use of public transport and more personal car use will balance this to at least some extent.

Overall, OPEC predicts that world oil demand will recover next year to 96.8 million bbl/d for the full year, still 3 million bbl/d down on the start of 2020, but prolonged Covid restrictions and delays in development or distribution of any vaccine could depress this further. Prior to the pandemic, the International Energy Agency had been predicting that global oil demand would grow by an average of 1 million bbl/d per year out to 2025, at which time it would start to plateau. Wood Mackenzie's most recent analysis suggests that 1 million bbl/d of demand could have been lost permanently, leading to consumption in 2025 still being 1 million bbl/d down on its level in 2019. A Covid-induced recession and the contraction in demand could see that gap being even larger.

### Excess supply

One issue that this creates for the global oil industry is that there is too much supply – this was true before the pandemic and the outbreak has merely worsened matters. Part of the issue has been a breakdown in OPEC discipline, caused by the cartel having a falling share of world oil supply. This in turn has been driven by output increases in Russia, and especially the US, where shale oil has added about half of all new global oil supply over the past decade. OPEC has cut its oil and

natural gas liquids production by 5.2 million bbl/d since 2016, but shale production has added 7.7 million bbl/d over the same period.

This year's contraction in demand has seen a corresponding response from OPEC, US shale production has also fallen. US crude output dropped from 12.7 million bbl/d in March 2020 to 10.1 million bbl/d in May, and at time of writing had recovered only to 10.5 million bbl/d. Shale oil output may decline in this new lower oil price environment – the shale oil sector has struggled to turn a profit, and with several years of lower oil prices potentially on the way, investors may be wary of committing themselves. However, it means that there is still plenty of potential supply out there, OPEC and non-OPEC, which could be brought back onstream quickly if oil prices increased. The oil industry cost curve is much flatter now than it was a few years ago, so relatively low oil prices may be with us for some years to come.

### Decarbonisation

In the longer term, the main threat to fossil fuel use is the so-called 'decarbonisation' of the energy business, as governments push towards greater use of renewable fuels. While in the past renewables often relied on government subsidies to compete with oil and gas, one of the more remarkable developments of the past few years has been the dramatic fall in costs of solar and wind-based electricity generation. International Energy Agency data shows that renewables, including wind, solar and hydropower, accounted for about a quarter of the electricity produced

in countries in the Organisation of Economic Co-operation and Development last year. The IEA says that it expects renewables meet to meet 80% of the growth in global electricity demand out to 2030. Hydropower remains the largest renewable source of electricity, but solar is the main driver of growth, and the IEA forecasts that it will set new records for deployment each year after 2022, followed by onshore and offshore wind.

Some major oil companies have already decided that they are going to gradually ease themselves out of the business. Fears over the future of the oil market has halved BP's share price over the past two years, and in August, BP published ambitious plans reach 50 gigawatts of renewable energy such as wind, solar and hydropower in its portfolio by 2030, up from just 2.5 GW now. The company also said that at the same time it would cut its oil and gas output by 40% over the decade. Eni in Italy has also committed to cut its oil production over the coming decade, though not by as much. In April Shell announced plans to become a net zero carbon emission energy business by 2050.

These targets are similar to some national targets which have been announced. The European Union is aiming to become 'carbon neutral' by 2050. Former vice president Biden has said that if elected he would institute a similar target for the US. China has set 2060 as its own target date. All of this is going to require a major shift in power generation capacity away from coal and, eventually, natural gas.

At the moment, renewable energy does not provide the return on investment that oil can. Large oil firms generally target a

## CONTENTS

What's in issue 391

### COVER FEATURE 1

Long term oil and gas output

### COVER FEATURE 2

The market for sulphuric acid

### COVER FEATURE 3

SRU oxygen enrichment

### COVER FEATURE 4

Materials for sulphuric acid service

SULPHUR  
ISSUE 391  
NOVEMBER-DECEMBER 2020

BCInsight

Southbank House, Black Prince Road  
London SE1 7SJ, England  
Tel: +44 (0)20 7793 2567  
Fax: +44 (0)20 7793 2577  
Web: www.bcinsight.com  
www.bcinsightsearch.com



Watch free fertilizer market presentations

Argus deliver concise and insightful webinars analysing the nitrogen, phosphate, potash, sulphur and sulphuric acid markets. The webinars are offered on-demand and live – and are completely free to watch.

Watch the free webinars here:  
[www.argusmedia.com/webinars](http://www.argusmedia.com/webinars)





Fig. 1: Long term oil/liquid fuels consumption

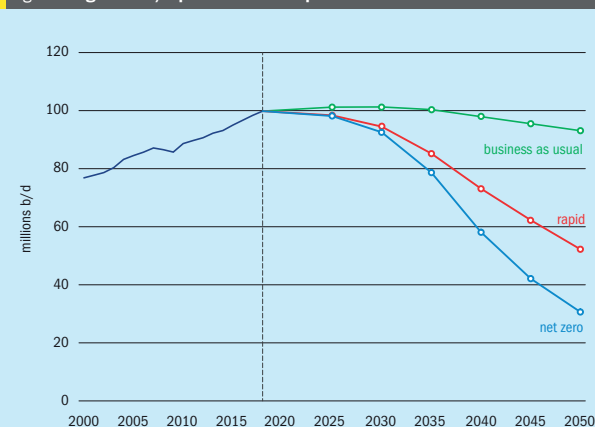

Source: BP

return on oil investments of about 15%, while BP said it expects returns of 8% to 10% from its low-carbon electricity investments. However, that gap is continuing to close, and in today's lower oil price market, that could reverse over the decade. Furthermore, renewables projects can provide more stable revenue streams via long term contracts and remove some of the exposure to the volatility of the oil market, as well as its uncertain geopolitics, such as sanctions and price wars. US sanctions have effectively taken Venezuelan and Iranian crude off the market.

### Electric vehicles

For the oil and refining industry, a potentially even greater threat to long term demand comes from a switch to electric vehicles. In 2010 there were an estimated 17,000 electric vehicles around the world. In 2019 there were over 7 million, half of them in China. Although Covid has seen total vehicle use decline by 15% this year, vehicle use is continuing to increase. Moreover, the share of electric vehicles continues to rise rapidly. The IEA now predicts that by 2030 there will be between 140 million and 250 million electric vehicles in service, representing between 7-13% of all vehicles on the road, and reaching up to a 30% market share in some sectors. This will displace an estimated 2.5-4.0 million bbl/d of oil demand.

Of course, an electric vehicle needs electrical power to charge it, so that increase will also increase global power demand, by 500-1,000 terawatt hours (TWh).

### Refinery sulphur

So what does all of this mean for refinery sulphur output? Refineries have been progressively increasing their sulphur output as regulations on sulphur content of fuels continue to tighten, and as refiners adapt to be able to utilise sourer (and hence often cheaper) grades of crude oil. It is hard to see much more sulphur coming from tightening road vehicle fuel regulations – most countries now permit only 50 ppm of sulphur in diesel and gasoline, and all of the developed world, including Russia and China, are down to a 10 or 15 ppm standard. The last major increase has come from the reduction in permitted sulphur content of marine fuels from 3.5% to 0.5% as part of the 2020 IMO regulations. There is still no agreed standard on sulphur content of aviation fuels, so that could still boost sulphur output, but by and large refinery sulphur output is now correlated closely with demand for refined products.

The IEA's most recent World Energy Outlook sees global oil demand still increasing over the next decade, but not returning to the level seen in 2019 until 2023-27, depending on the scenario. However, it also acknowledges that if countries are serious about their net zero carbon tar-

gets, oil demand could peak more quickly and fall faster than in its guideline scenarios. It posits that a 'sustainable development scenario' would see the current recovery in demand plateau about 4 million bbl/d down on 2019 in around 2023, and thereafter start to gradually fall. BP's projections (see Figure 1) posit a peak at 2030 even under 'business as usual' conditions, and a potentially more rapid fall.

On the other hand, upward pressure on liquids demand could come from rising use as a feedstock in the petrochemical sector. Despite an anticipated rise in recycling rates, there is still plenty of scope for demand for plastics to rise, especially in developing economies. At present these are primarily sourced from natural gas liquids (NGLs) and would not necessarily pass through the refining sector, but the refineries of the future may diversify into other feedstocks and business areas, increasing their petrochemicals production, and perhaps taking in chemical recycling, biofuels production, or hydrogen production, as a way of securing new revenue sources.

Overall, while some refineries, especially in Asia and the Middle East, are still installing new coking and hydroprocessing and hydrodesulphurisation capacity, the increase in sulphur production from refineries, especially as global oil demand plateaus over the coming decade, may be relatively small. This year has seen a significant fall in refinery sulphur output as oil demand has been down. USGS figures show that US refineries produced 6% less sulphur in 2020 (4.29 million tonnes) compared to 2019 for the seven months to July.

### Sour gas

On the face of it the future for natural gas is potentially brighter than for oil. As noted above, the world will need more electricity over the coming years, with demand rising from 28 TWh today to 32-34 TWh by 2030, according to the IEA. And, while much of new generation capacity will come from renewables, natural gas will replace falling coal-based generation as a lower carbon (and lower SO<sub>2</sub> and other pollutants) option. Natural gas demand for power production is forecast to rise by 15-30% over the next decade, with South and East Asia responsible for most of this. The IEA does not think that demand for gas will peak until the late 2030s, as electrification of heating and development of renewables erode long-term demand.

Sulphur 391 | November-December 2020

As with oil, the coronavirus pandemic has had an impact on gas demand, which has fallen by an estimated 5-10%, although it will recover much faster than oil. However, the liquefied natural gas (LNG) market, via which most gas is transported between regions, was oversupplied before Covid, and hence is even more oversupplied now. Prices are low, and abundant US shale gas production has generated large volumes of gas with a break-even cost lower than \$2.50-3.00/MMBtu. With North America becoming one of the largest LNG exporters by the early 2020s, regional gas prices in Europe and Asia will be driven by prices at Henry Hub, plus cash costs for transportation and liquefaction (a premium of about \$1/MMBtu to \$2/MMBtu).

Sour gas production tends to be more expensive than sweet gas, because it must factor in the cost of processing and recovering H<sub>2</sub>S and CO<sub>2</sub> from the gas stream. This single fact has been the main reason for the decline in production of sour gas in North America and Europe, as it is undercut, in the US case by cheaper shale gas, and in Europe by imports from Russia, Norway, Algeria and increasingly now by cheap LNG. The regions that have become major producers of sour gas – China, the Middle East, and Central Asia – have done so for reasons particular to those regions; in China and the Middle East to boost domestic gas production where no sweet alternatives are available, and in the Middle East and Central Asia to process gas associated with oil deposits.

There are still major sour gas projects under development, especially in Central Asia and the Middle East. However, an era of low gas prices has placed question marks over some of those projects, at the very least in terms of timing. Where gas is associated, new projects are increasingly looking at reinjection of acid gas after it is separated from sales gas, in order to maintain reservoir pressures, such as at the Tengiz Future Growth Project in Kazakhstan.

There are major sulphur-producing sour gas projects still on the horizon. Abu Dhabi is looking to expand production at the Shah complex by 50% in a few years' time, adding 1.7 million t/a of sulphur, and the commissioning of the Barzan gas project in Qatar this November will add 800,000 t/a more sulphur output at capacity. Further LNG expansions in Qatar are also slated, although the current glut in the market may push their timescales back. There are also more prospects for Central Asia, including the Galkynysh field in Turkmenistan. However, many of the big sour gas projects are now operational, and the current investment environment may mean new ones only proceed slowly.

### Sulphur demand

Set against slowing growth in sulphur output, what of the future of sulphur demand? Sulphur is mainly (>90%) used for sulphuric acid production, and that is primarily used in the treatment of rock to recover mineral salts. Most goes into phosphate recovery for fertilizer production, but an increasing amount is also used for recovery of copper, nickel, uranium and other minerals. The rest of the sulphuric acid goes to a variety of different industrial processes, from titanium dioxide to caprolactam production. None of these are showing any signs of slowing down – phosphate production is continuing to increase, particularly in North Africa, the Middle East, Russia and India, averaging about 1.5% year on year growth. Acid demand for industrial uses continues to increase steadily. And the need to produce batteries for electric vehicles has led to a spurt in demand for acid to process nickel laterite ores into nickel sulphate.

Sulphur 391 | November-December 2020

## CONTENTS

What's in issue 391

## COVER FEATURE 1

Long term oil and gas output

## COVER FEATURE 2

The market for sulphuric acid

## COVER FEATURE 3

SRU oxygen enrichment

## COVER FEATURE 4

Materials for sulphuric acid service

## Sulphur balance

With sulphur production from oil likely to peak or at least plateau in the next few years, and a slowing increase from sour gas projects, set against continuing rising demand for sulphuric acid, this may mean a sea change in the sulphur industry a decade or so down the line. Continued strong demand for sulphur, tight availability and rising prices will no doubt initially be met by the melting down of existing sulphur stockpiles. The plethora of forming projects that are being announced in Alberta may be a harbinger of that. However, even the 8 million tonnes of sulphur at Syncrude may only represent sufficient supply for a few years of deficit, after which conditions may become more difficult.

At the 2018 Sulphur Conference in Gothenburg, Sweden, Peter Clark, former director of Alberta Sulphur Research Ltd, took a look at the much longer term future, out to 2050, and suggested that higher prices for sulphur could change the economics of sour gas production; with sulphur as a co-product rather than a by-product, it might spur some sour gas developments that otherwise might have struggled to find financing. Likewise there is the potential, in a high sulphur price environment, for a return to Frasch mining, largely abandoned since the 1990s, and switch back from acid gas reinjection to sulphur recovery. Some substitution may also be possible – using nitric acid produced from ammonia instead, for example, in some processes. However, it seems increasingly likely that the times of sulphur surplus may soon be behind us for good.



— An ITT Brand

## Pumps specialist for the sulphur industry

Rheinhütte Pumpen supplies chemically resistant centrifugal pumps to handle molten sulphur and sulphuric acid. Optimal customer and engineering solutions are provided in a large selection of more than 30 metal and plastic materials combined with special shaft seals.



**SULPHUR**  
**ISSUE 391**  
NOVEMBER-DECEMBER 2020



ITT RHEINHÜTTE Pumpen GmbH  
Rheingaustraße 96-98 | D-65203 Wiesbaden | www.rheinhuette.de



Sulphur reports on this year's Sour Oil and Gas Advanced Technology (SOGAT) conference, which was run as a virtual event at the end of September 2020.

This year's coronavirus outbreak had pushed the date for the Sour Oil and Gas Advanced Technology (SOGAT) conference, organised by Dome Exhibitions, back from its usual spring slot to a date at the end of September and, when that time came around, also forced it to move from its usual home of Abu Dhabi to the internet, with speakers and delegates joining via conferencing software. Nevertheless, the standard of papers remained high, and there was keen interest from attendees.

Abu Dhabi has rapidly become the centre of the Gulf's sulphur industry, and state oil and gas company ADNOC the world's largest producer, courtesy of its sour gas assets such as Shah and Habshan. The conference began with several presentations which dealt with sulphur recovery unit (SRU) operations.

### Oxygen enrichment

Mahin Rameshni of RATE Technologies gave a paper on the expansion of SRU capacities using oxygen enrichment. In the paper she presented a case study on a refinery revamp. The refinery has two existing SRU's, each with a capacity of 75 t/d. It had recently added a new hydrotreater, amine and other units, and

as a result needed to process significant volumes of amine acid gas and ammonia acid gas. Five options were considered and compared, including adding a new full or partial SRU, but the choice basically boiled down to adding oxygen enrichment to each train separately (Option 1) or via a common section (Option 2), or modifying the existing sour water stripper to become a two stage SWS to process all of the ammonia, with the ammonia either collected for sale or passed to an incinerator (Option 5). The cost comparison showed all three options were close, with 1 and 2 having the lower capital cost, but the customer was not keen on the ongoing operating cost of buying oxygen, and so option 5 was the one eventually chosen.

Maher Abdulatif of Saudi Aramco also considered oxygen enrichment in a recent engineering assessment for construction of a new green field gas processing facility in Saudi Arabia. The base case would have comprised eight air-based SRUs, three of them to be deployed in Phase 1 and a further five in Phase 2, which would triple the capacity of Phase 1, all using two Claus stages and a tail gas treatment unit, to achieve Aramco's specification of 99.9% sulphur recovery. The specifications also called for a low turndown percentage

(15%) to cope with a low feed ramp-up of operations. Two cases of oxygen enrichment were considered; using enrichment only in Phase 2 (bringing the total down to 3 SRUs in Phase 2), or using pre-investment allowing the Phase 1 SRUs to switch to oxygen enrichment in Phase 2, bringing the total SRUs down to two in Phase 2 or five in total. The latter led to a 20% reduction in capital expenditure and was the one finally chosen.

### Ammonia destruction

Upstream units in a refinery can generate ammonia in fluid catalytic cracking or catalytic reforming, amongst many other processes, which passes into the sour water stripper and thence via the main reaction furnace to the SRU. This can place extra hydraulic load on the SRU, requiring a larger unit. Ammonia can also react with SO<sub>2</sub> to form ammonium salts which can deactivate catalysts increase pressure drop. As an alternative to ammonia destruction at the furnace exit, Ruben Kranenburg of Duiker Combustion Engineers presented his company's Stoichiometrically Controlled Oxidation (SCO) unit, which handles ammonia separately and uses the hot effluent from the ammonia section to heat the tail gas treatment unit. To avoid NO<sub>x</sub> formation, the first section is a reducing zone, with a sensor deciding on the air feed to the reducing zone to maximise ammonia destruction. The second stage uses excess oxygen at a moderate temperature to fully convert remaining ammonia with low NO<sub>x</sub> formation (<70 ppm).

Abijet Raj of King Abdullah University in Abu Dhabi also covered ammonia destruction. It is a complex and little understood area, he said, so he had attempted to build a computer model of conditions in a reaction furnace and waste heat boiler. The model was then validated via real world test results from the Habshan V sulphur plant, and data from Canada on oxygen enrichment studies and reported data in the literature, and the modelled concentrations compared well with plant data. Once validated, ammonia destruction was investigated, including the effect of feed pre-heating temperature, furnace length/residence time, oxygen enrichment etc.

### Sulphur handling

Hani El Gheriani of Enersul considered the perennial problem of sulphur dust. Sulphur has a lower explosion limit of 35 g/m<sup>3</sup>, and an auto-ignition temperature of 190°C,

making it one of the most easily ignited substances in bulk handling. It can be set off by friction or static sparks, and detonations can raise more clouds of dust, leading to even larger, secondary explosions. As a result, handling systems need to be designed to minimise dust formation via several considerations, such as reducing the number of transfer points. Drop distances need to be as small as possible, and conveyor belts anti-static and fireproof and using brush wipers to clean them. Electrical insulation needs to have the appropriate hazardous area certification, and all metal components need to be properly earthed. Dust generation can never be eliminated, so dust control systems, using sprayed water, surfactant or foam, or dust collection systems, preferably using a wet scrubber, are also essential if sulphur dust is to be properly controlled. Hani also suggested minimising stockpile heights, as older formed sulphur becomes more friable and can be crushed by the weight of product on top of it.

Justin Tucker and Dan Campbell of CSI Ametek showcased their 'total heating solutions' for sulphur (or other fluid) pipeline temperature monitoring and steam tracing or jacketing. The approach uses a finite element analysis and computational fluid dynamic (CFD) modelling to determine and optimise what thermal coverage is needed for any given stretch of pipe in order to provide thermal process guarantees while minimising associated infrastructure such as manifolds and steam traps.

### Safety and reliability

Ali Moncur of SMS discussed improving personnel safety during H<sub>2</sub>S sampling operations using a closed loop real time inline H<sub>2</sub>S analyser, together with a case study of its use during an onshore well test in the UAE. The system has some limitations in terms of range of H<sub>2</sub>S concentrations and pressure, but eliminates more dangerous tube sampling methods.

Prasanth Sreekumar of Endress+Hauser spoke on improving the efficiency and safety of gas processing plants. Reliable gas flow measurement is necessary, especially where feed gas composition can vary. Too low a flow rate may lead to efficiency loss and inadequate absorption of acid gases, while high flow rates in a contactor can lead to amine foaming or carryover and reboiler overloading. The presence of water can lead to corrosion and formation

of gas hydrates or lower heating values of the sales gas. Endress+Hauser supplies ultrasonic monitors which can work accurately under wet gas conditions. It also has spectroscopic sensors which can measure gas quality, including CO<sub>2</sub>, trace H<sub>2</sub>S levels, and oxygen levels.

Elmo Nasato of Nasato Consulting, in cooperation with Industrial Ceramics, looked at waste heat boiler (WHB) reliability. As WHBs have moved to higher pressures it has meant that much greater focus must be paid to an understanding of water chemistry, especially for facilities that have a range of WHB operations. Ferule issues can often be misdiagnosed as a problem with the ferrules themselves, with a rush to replace tube sheet linings or tubes, when they can be a symptom of a process or more likely a water side issue. A full root cause analysis (RCA) needs to be conducted as soon as possible in order to avoid chronic and more serious failures. Intermittent boiler blowdown needs to be a routine procedure, performed 2-3 times per day. He presented a case study where this was ignored, leading to two WHB failures in 10 months.

### Tail gas treatment

Georgios Lithoxoos of Saudi Aramco described the development of an adsorption-based tail gas treatment process at Aramco's gas processing plants. A typical SRU at an Aramco gas plant comprises two Claus reactors and a Superclaus reactor, with a tail gas treatment section, with sulphur recovery between 98.7-99.1%. However, the Saudi authorities moved to a 99.9% recovery standard in 2014, necessitating an upgrade of the SRUs. Aramco looked at a temperature swing adsorption-based process described in the literature using a molecular sieve and modified zeolites to selectively remove H<sub>2</sub>S from the tail gas of SRUs. However, the paper did not consider water presence in the gas, and proposed air as a regeneration gas, which would have created sulphur deposition in wet conditions. Aramco developed the process to include a quench tower and cooler to remove water from the gas stream, and tested various zeolites for their effectiveness. The process has since been demonstrated on a side stream from a gas plant SRU. Future planned developments include optimising the process design, including the temperature and flow rate of the regeneration gas.

### SRU operations

Uday Parekh of Blasch Precision Ceramics spoke about how to achieve an optimised temperature profile in the SRU reaction furnace and thermal oxidiser. Smooth operation of an SRU reaction furnace is critical to trouble-free operation. And Uday said that three Ts determine how efficient combustion is – time, temperature and turbulence. Blasch has been progressively improving its hexwall and checkerwall designs, and now provides the VectorWall, which creates a turbulent flow downstream of the wall, improving mixing and residence time and leading to higher temperatures in the furnace, both in front and behind the wall, leading to more complete combustion, while maintaining an open face area that minimises the pressure drop. It also eliminates vibrations which can occur with conventional choke rings, and improves ammonia and BTX destruction.

### Energy optimisation

In the final session, Sami al Mutairi of Saudi Aramco detailed an energy optimisation assessment case study, with simultaneous process and utility integration, to optimise project life cycle cost. The new facility involved the installation of additional units in an existing gas processing plant, in this case of a dew point control unit, de-ethaniser and condensate stripper in order to meet the required product specification. The assessment resulted in energy and capital savings as well as CO<sub>2</sub> reductions and assuring that the facility was energy efficient while satisfying the intended objectives.

Saqib Sajjad of ADNOC Gas Processing presented a thermodynamic analysis of energy recovery from pressure reduction systems. He paper examined using a back pressure steam turbine in place of steam pressure reduction station to supply low pressure steam to regenerators, and explained its impact on the load on boilers supplying high pressure steam. He also analysed the impact of replacing an amine absorber level control valve with a hydraulic turbine, in a gas sweetening unit, on amine regeneration and overall energy consumption.

Next year's SOGAT is provisionally scheduled to be held in Abu Dhabi between April 29th-31st 2021, but of course, that very much depends upon the course of the virus. ■

CONTENTS

What's in issue 391

COVER FEATURE 1

Long term oil and gas output

COVER FEATURE 2

The market for sulphuric acid

COVER FEATURE 3

SRU oxygen enrichment

COVER FEATURE 4

Materials for sulphuric acid service

SULPHUR  
ISSUE 391  
NOVEMBER-DECEMBER 2020

BCInsight

Southbank House, Black Prince Road  
London SE1 7SJ, England  
Tel: +44 (0)20 7793 2567  
Fax: +44 (0)20 7793 2577  
Web: www.bcinsight.com  
www.bcinsightsearch.com



# The year that went viral

A look back at some of the major events of 2020 for the sulphur and sulphuric acid industries, as well as a look forward as to how 2021 might look.

It is hard to begin a review of 2020 without mentioning the coronavirus pandemic. Beginning in China in January, it was having serious effects by February, soon moving on to the rest of East Asia. Europe and North America soon followed, and by the end of March, the pandemic led to extended 'lockdowns' for billions of people, and still continues to work its way around the world, with South America and India now badly affected, while the colder months in the northern hemisphere and more people spending time indoors are feeding a 'second wave' of cases in Europe and America.

The effect upon economies has been profound, confining people to their homes for extended periods, and shutting down all manner of economic activity, from long distance travel to sporting events. Oil and gas prices have slumped as demand has fallen, and most of the world has spent the year in recession.

For the chemical process industries, much of the disruption has been via the almost complete shutdown of international air travel and associated quarantine regimes that mean people are simply not able to travel. Face to face conferences have become a thing of the past, and we have all had to become familiar with the ins and outs of video conferencing. Engineers have not been able to go to sites to oversee plant construction or start-ups or deal with production problems.

## Sour gas

On the sour gas side, the Fadhili gas plant in Saudi Arabia (pictured, right) came on-stream in March 2020, with 1.3 million t/a of sulphur capacity and Qatar's Barzan project is still expected this year, although that has been the case for some years now! However, other investments are being put back. Qatar has pushed the next phase of its North Field development back to 2025, for example, with revised tenders coming in during October. Oil majors have also become nervous about investments. Eni announced a review of its operations in March, including participation in the Ghasha development, and by April ADNOC had terminated \$1.65 billion worth of projects related to the Dalma sour gas field development, part of the Ghasha mega-field, which had been scheduled for a 2022 operational date. The project was re-tendered in August.



PHOTO: SAUDI ARAMCO



Total's Antwerp refinery, Belgium.

PHOTO: MAIRE TECNIMONT

PHOTO: NHEMZ/SHUTTERSTOCK.COM

## Refining

For a while during March, as oil demand dropped due to the impact of Covid-19, the situation in oil markets was exacerbated by Russia's refusal to lower its output in line with proposed OPEC moves. This led to a brief oil price war, as Saudi Arabia flooded the market with its own production. This in turn saw oil prices drop by 65%, and WTI forward prices briefly went negative. The price slide was only halted by a Russia-OPEC deal in April, and extended in June, which led to 10 million bbl/d of production cuts. Low oil prices also forced a number of shut-ins at US shale-based producers, and US oil output fell by 2.5 million bbl/d.

In the run-up to January 2020, refiners had been struggling with the impact of IMO regulations and high demand for low sulphur fuel oil and distillates at the expense of high sulphur fuel oil, and many refineries switched to sweeter crude grades. However, the impact of the virus on refiners was a dramatic fall in demand for jet fuel and gasoline. This put a premium on heavier crude grades and sweet-sour price spreads almost disappeared.

The impact of lower refinery operating rates has been a fall in sulphur production, albeit only about 6% in the US, although exports to August were down by one third. It also put paid to any further thoughts of Saudi Aramco extending its IPO, which had led to the sell-off of 1.5% of the company in December 2019, at already somewhat disappointing prices as far as the Saudi government was concerned.

There were some new refinery completions, including Fujian in China and the Clean Fuels Project in Kuwait (pictured, right), the latter of which, together with the nearby Al Zour refinery, are expected to add 2.3 million t/a of sulphur capacity.



PHOTO: EMIRATES WATER &amp; ELECTRICITY COMPANY

PHOTO: STREAMLINE INNOVATIONS

Below: Large Valkyrie™ plant under construction.



## Technology

Technologies that *Sulphur* has highlighted this year include:

- Refinery green fuel integration with a sulphur complex (Jan/Feb).
- The Valkyrie redox process for H<sub>2</sub>S removal (Mar/Apr).
- A new highly selective H<sub>2</sub>S removal solvent (Jul/Aug).
- Lessons from SRU start-up and shutdown case studies (May/Jun).
- State-of-the-art processes for mercaptans removal (Sep/Oct).
- Topsoe's Clearview and DynSox process monitoring and simulation software (Jan/Feb).
- BASF's new promoter system, OASE yellow, compatible with MDEA solutions (May/Jun).
- Fluor's new generation D'GAASS3G sulphur degassing technology (Mar/Apr).
- Enersul's SafeFoam sulphur dust suppression system (Jul/Aug).
- Industry experience and guidance for preventing explosions in molten sulphur tanks (Sep/Oct).
- Design challenges for mega acid plants (Jul/Aug).

## Sulphuric acid

Chinese smelter acid supply continued to increase, leading to some merchant supply out of China, especially after Covid hit – Chinese smelters were reluctant to shut down, and acid production soon outstripped storage capacity, leading to negative c.f.r prices at Chinese ports, and similar knock-on effects in Korea and Japan. European prices also went negative in April, not recovering to positive values until July. In other supply side news, Glencore's Katanga acid plant, with 1,900 t/d of capacity, saw its commissioning postponed from March to the end of 2020.

Chilean acid supplies and demand were disrupted by Covid-related shutdowns at copper mines and smelters. The Cuzicamauta smelter was closed down from June to August. Overall, Chilean acid imports were forecast to be down to around 2.8 million t/a for the full year.

In India, legal wrangling over the Tuticorin smelter continued. In the meantime, Indian demand for acid was impacted by shutdowns in the phosphate sector, although with acid prices cheap, many producers shut sulphur burning acid plants and imported Chinese acid instead. Indian acid demand is expected to be 15% down this year.

The bright spot was Morocco, where OCP manage to continue to run its phosphate operations normally and continued buying significant volumes of acid.

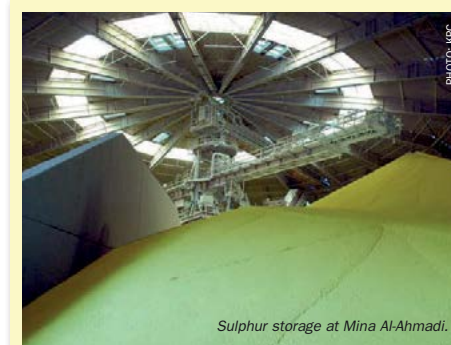

Sulphur storage at Mina Al-Ahmadi.

PHOTO: IFC

## Sulphur

Sulphur prices started the year low, at below \$40/t f.o.b. Middle East, but rose on a combination of supply disruptions, from refinery shutdowns or slowdowns to quarantine restrictions at major ports. A shutdown of Chinese phosphate plants in March due to coronavirus led to a record build-up of sulphur at Chinese ports, reaching 3.2 million tonnes in March, and Chinese 1H imports were down by 28% on the same period for 2019, at 4.2 million tonnes.

Elsewhere, the restart of Ravensthorpe Nickel in Australia in May, with its sulphur-burning acid plant, was balanced by a Covid-forced shutdown at Sumitomo's Ambatovy site on Madagascar in April, forecast to last until 1Q 2021. At Goro in New Caledonia, Vale was looking for a buyer for its HPA nickel operations, but when Australia's New Century Resources walked away from the sale in September this year, indicated that the plant would be moving to care and maintenance unless a "sustainable solution" could be found in the next few months.

Indian phosphate demand was disrupted in the early part of the year, but returned by May-June.

The sulphur market ticked on at around \$60/t for much of the year, but has seen some more gains towards the end of the year as supply availability tightens.

## Next year

The pandemic appears to be with us for the long haul, with Europe experiencing a 'second wave' of cases as winter forces people indoors, and lockdowns returning. Widespread deployment of a virus still appears months away at best. Many industries have become better at operating in virus-safe conditions, and phosphate fertilizer demand seems set to continue to be strong, but many other industries are operating at reduced rates. The hangover seems worst for refiners, where it may take months or even years for demand to return to pre-pandemic levels. Although this would appear to have a more pronounced effect on sulphur supply than demand in the short term, the start-up of several new sulphur producing refineries and gas plants during 2020, especially in the Middle East, may see a ramp-up of sulphur production in the region which more than offsets this. China is also seeing reduced import requirements due to new refinery start-ups. There are a number of new remelter projects, in Europe and Canada, which may also alter sulphur market dynamics and reliance on liquid sulphur. ■

## CONTENTS

What's in issue 391

## COVER FEATURE 1

Long term oil and gas output

## COVER FEATURE 2

The market for sulphuric acid

## COVER FEATURE 3

SRU oxygen enrichment

## COVER FEATURE 4

Materials for sulphuric acid service

SULPHUR  
ISSUE 391  
NOVEMBER-DECEMBER 2020

BCInsight

Southbank House, Black Prince Road  
London SE1 7SJ, England  
Tel: +44 (0)20 7793 2567  
Fax: +44 (0)20 7793 2577  
Web: www.bcinsight.com  
www.bcinsightsearch.com



# Sulphuric acid markets



The sulphuric acid plant at the Dundee Precious Metals smelter, Tsumeb, Namibia.

Although 2019 had been a volatile year for acid markets, with shutdowns disrupting supply, the coronavirus outbreak wrought even more havoc in 2020, across both supply and demand.

As with most other sectors, the coronavirus outbreak has dominated sulphuric acid markets this year. The start of 2020 saw China affected by coronavirus, but with smelters continuing to operate and looking for outlets for their acid. In spite of shutdowns at some domestic sulphur burning acid capacity, Chinese acid prices went negative in February. Lack of buying interest from China and Chile forced Japanese and Korean prices negative as well, falling to \$-45/t by April, and this eventually also forced European acid prices negative by April, but buying from Morocco helped support prices and they moved back positive – though low – by July.

## Phosphates

On the demand side, the major use is phosphoric acid production. Global phosphate markets began 2020 oversupplied, but fertilizer production by and large managed to continue through the year, in spite of some shutdowns in India around April-May. Strong demand from both Brazil and India lifted phosphate prices over the course of the year. Indian DAP demand was boosted by record planting and a good monsoon season, while Brazil was looking at near

record soybean production. In Morocco, OCP continued to be a strong buyer. The phosphate producer imported 1.56 million t/a of acid in 2019, and this is expected to be higher in 2020. Argus reported that July saw record acid imports of 270,000 tonnes, and full year figures could reach 1.7 million t/a, up 9% on 2019. Consumers like OCP are able to switch between sulphur burning acid production and purchasing merchant acid. When sulphur prices are low it tends to encourage sulphur burning production, but when, as this year acid prices are low or even negative, it tends to encourage more acid purchasing.

## Metals

The seaborne sulphuric acid market is dominated by involuntary production from smelter acid producers. Sulphur burning acid plants tend to be located near sources of demand and their production is effectively captive. Only around 10% of acid trade is represented by sulphur burning acid production, with smelters making up the rest – the fortunes of the metal smelting market are thus key to sulphuric acid prices.

Copper prices slumped in the first part of 2020, from \$6,000/t to \$4,800/t, because

of fears that Covid disruption would bring a deduction in Chinese demand – China represents the lion's share of global copper demand. However, as China recovered, so did copper prices, and by September they were up to \$6,800/t. Disruption to Chilean copper production (see below) has led to tightening in copper markets.

As well as new copper smelters, there is some additional leaching capacity. In the US, Freeport-McMoRan (FCX) said in August that its 90,000 t/a Lone Star, Arizona copper leaching project was "substantially complete" and would be producing before the end of the year. Sulphuric acid consumption for the project – around 850,000 t/a when it reaches capacity in 2024 – is expected to mostly be sourced from the company's own production.

## Nickel

Nickel has been a fast growing area for sulphuric acid demand. Demand for nickel for batteries continues to increase, requiring higher grade nickel production, and leading to a large-scale revival of interest in high pressure acid leach (HPAL) production, consuming large volumes of sulphuric acid.

Nickel prices have been highly volatile, dropping from \$18,000/t in October 2019 to \$11,500/t in March 2020, before recovering to around \$14,500/t. However, projections of a shortfall in nickel supply by the middle of the decade are nevertheless leading to considerable investment in new nickel capacity, especially in Australia and Indonesia. In Australia, BHP is due to begin production soon at its Nickel West site, ramping up production to 100,000 t/a, with potential expansions further down the line. Nickel's renaissance has also been behind the restart of First Quantum's Ravensthorpe HPAL site. Ravensthorpe was expected to produce 15,000 tonnes of nickel this year, and is projecting output of 25-28,000 t/a in 2021 and 2022, although it generates acid from sulphur burning.

In Indonesia, there are now six HPAL plants under construction or planned. This could increase Indonesia's acid consumption by up to 2.4 million t/a by 2024, although most of this will be met by domestic sulphur burning acid plants.

## Chile

Chile faced a coronavirus outbreak in June and July which saw a number of mine workers infected. The Antofagasta region, the heart of Chile's copper mining belt, was particularly badly affected. Covid safety measures led to a slowdown in production at existing sites, and work on new production capacity was halted at expansion projects including Teck Resources' Quebrada Blanca phase 2 project, Antofagasta Minerals Los Pelambres expansion project, and Codelco's Rajo Inca and Chuquicamata expansions. Codelco's Chuquicamata smelter was offline for several weeks, losing 20,000 tonnes per week of acid production. The demand side was also affected, as SX/EW facilities instituted social distancing measures, or instituted temporary closures. Overall, Chile's acid demand is expected to be down this year, perhaps as low as 2.7 million t/a.

## India

The acid situation in India continues to be significantly impacted by the forced shutdown of the Sterlite Copper smelter at Tuticorin.

Tuticorin had 1.2 million t/a of acid capacity, and its absence has led to increased Indian imports of acid to make up for the shortfall. There has been no definitive judgement in the legal battle, and there are concerns that the smelter may need extensive remedial work to bring back on-stream. Indian phosphate production was disrupted around April but soon returned to production, but Covid had a greater impact on industrial acid demand. Indian acid demand appears to be about 15% down on the year, though phosphate producers continue to be strong buyers, preferring to purchase cheap acid over more expensive sulphur, which is nevertheless boosting imports, possibly to record levels this year.

## Production

East Asian smelters are the source of large volumes of merchant acid. Japan and South Korea continue to be major exporters of sulphuric acid from their smelting industries. Japanese acid exports were up 12% this year, reaching 2.5 million tonnes to September, with Sumitomo's nickel plant in the Philippines a major consumer.

In spite of the cancellation or suspen-

sion of some smelter projects, increasing smelter acid production in China is affecting domestic markets and driving some production onto export markets. China exported more than 2 million tonnes of acid in 2019, mainly to Morocco, up 70% on 2018. Chinese acid imports, mainly from South Korea fell accordingly, down 50% in 2019. However, this year lack of demand in Chile and low acid prices forced the temporary closure of the Two Lions acid plant, and Chinese exports were down 12% at 1.4 million tonnes by the end of September. Another 800,000 t/a of smelter acid capacity is expected to come on-stream during 2021.

Elsewhere, production of sulphur-burning based acid is due to rise when a new plant comes on-stream for the Kamoto Copper Company in the Democratic Republic of Congo, although Covid has disrupted start-up. Once the plant is up and running, it will potentially displace smelter acid from Zambia's Mopani copper smelter, although the latter has also faced Covid-related disruptions and is currently on care and maintenance.

Overall, 2020 is expected to see a decrease in acid production globally, especially in the sulphur burning sector. ■

## HIGH PERFORMANCE ALLOYS FOR CORROSIVE ENVIRONMENTS

Sverdrup Steel is a material solution provider and your perfect partner for high-grade stainless steels and nickel alloys for corrosive environments. We have sheets, plates, pipes, fittings and round bars in the most common grades available in stock in Norway, Sweden, UK, Germany and Korea.

### Most common grades in stock

Super Duplex S32750 / 1.4410 / 2507  
Super Duplex S32760 / 1.4501 / Zeron 100  
Lean Duplex S32101 / 1.4162 / LDX 2101  
Lean Duplex S32304 / 1.4362 / EDX 2304  
Super Austenite S31254 / 1.4547 / 254SMO  
Super Austenite N08904 / 1.4539 / 904L

Duplex S31803 / 1.4462 / 2205  
Super Austenite N08031 / 1.4562 / Alloy 31  
Nickel Alloy 625 / N06625 / 2.4865  
Nickel Alloy 718 / N07718 / 2.4668  
Martensitic Alloy 1.4542 / 17-4PH / AISI 630  
Martensitic Alloy 1.4418 / S165M / 2387

**SVERDRUP  
STEEL**

sverdrupsteel.com

## CONTENTS

What's in issue 391

## COVER FEATURE 1

Long term oil and gas output

## COVER FEATURE 2

The market for sulphuric acid

## COVER FEATURE 3

SRU oxygen enrichment

## COVER FEATURE 4

Materials for sulphuric acid service

SULPHUR  
ISSUE 391  
NOVEMBER-DECEMBER 2020

**BCInsight**

Southbank House, Black Prince Road  
London SE1 7SJ, England

Tel: +44 (0)20 7793 2567

Fax: +44 (0)20 7793 2577

Web: www.bcinsight.com  
www.bcinsightsearch.com



# New ways with oxygen enrichment technology

New approaches and novel processing schemes employing oxygen enrichment in sulphur recovery units have been developed and commercialised. In this feature Siirtec Nigi, Linde, Blasch, Fluor and RATE report on their latest developments.

**SIIRTEC NIGI**

## SplitOxy: a renewed approach to oxygen enrichment

D. Scilla

Using oxygen-enriched air in the Claus process is recognised as one of the most effective ways to improve sulphur processing capacity. The objective of the enrichment process is to reduce the amount of inert gas involved in the Claus process by adding pure oxygen to atmospheric combustion air.

In fact, the main limitation to Claus unit capacity increase is the pressure drop across the plant. Therefore, capacity increase with oxygen-enriched air means that more acid gas feed can be sent to the Claus unit within the overall hydraulic capacity constraints.

Oxygen enrichment not only meets the purpose of increasing sulphur recovery unit (SRU) throughput, but it also comes with a number of benefits for SRU operation and can be provided in a new unit or as a retrofit to existing units.

When revamping an existing Claus unit with oxygen enrichment, the maximum enrichment level that is expected to be achieved, often originated from the

expected required extra capacity, dictates the corresponding design approach.

A novel oxygen enrichment technology application in the medium-high oxygen enrichment level, the Siirtec Nigi's SplitOxy technology, has been studied and recently supplied to revamp the SRU-IV in Ecopetrol's Gerencia Refinería Barrancabermeja in Colombia.

The SplitOxy technology by Siirtec Nigi was recently presented as part of the technical agenda in the Virtual Sulphur + Sulphuric Acid 2020 conference.

### The role of temperature

There are various levels of oxygen enrichment that can be applied to a Claus process. Most technologies, however, are grouped into the three categories shown in Table 1.

Whilst low/medium-level oxygen enrichment can, in theory and in practice, be achieved by virtually every sulphur recovery unit at minimum cost, at higher oxygen

concentrations the reaction temperatures are likely to reach over 1,550°C with the potential to approach the limit of the refractory lining material of the Claus reaction furnace (1,700°C).

Depending mainly on the acid gas composition, the upper limit of oxygen enrichment level for SRUs in refinery applications (approx. 34-36 vol-%) has to be defined in order to keep the reaction furnace (RF) temperature below 1,550°C.

In addition, the waste heat boiler (WHB) and the sulphur condensers need to be checked to ensure they also have adequate heat transfer capabilities with oxygen enrichment operation.

One proven concept for implementing high-level oxygen enrichment is to inject into the Claus burner only a part of the oxygen required to achieve the Claus stoichiometry, whilst keeping the operating temperature of the reaction furnace well below the refractory limit. This is possible by adding oxygen in a stepwise manner, which allows for intermediate removal of reaction heat, thereby

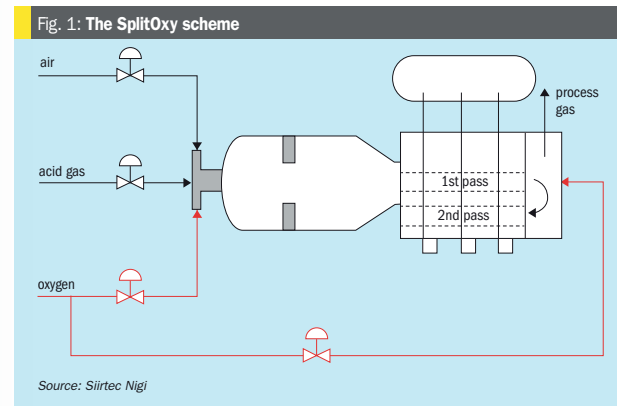

postponing part of the combustion to a secondary chamber located in the rear end of the WHB, where the gas temperature is still high enough for further H<sub>2</sub>S conversion. This is the SplitOxy technology.

### The SplitOxy technology

The concept is straightforward: the temperature limitation can be overcome by splitting the oxygen supply into two streams. The main oxygen stream is fed into the Claus burner while the slipstream is fed into the rear end of the WHB after intermediate removal of reaction heat (Fig. 1).

Significantly, there is no sulphur condenser between the WHB and the second reaction chamber. There is also no burner in the second reaction chamber. Effluent from second reaction chamber flows through the WHB second pass and then

to the condensing passes and catalytic stages.

By design, under all operating conditions the gas exiting the WHB first pass and entering the second reaction chamber is substantially above the H<sub>2</sub>S auto-ignition temperature.

Through process optimisation, it is possible to identify a fixed oxygen split ratio to be maintained in the entire operating range in order to limit the reaction furnace temperature within the desired envelope while enhancing the conversion efficiency.

The temperatures in the reaction furnace and the second reaction chamber in the SplitOxy process for a typical rich refinery gas with significant ammonia presence are shown in Fig. 2, as overall oxygen concentration is increased from 25 to 45 vol-%.

At constant oxygen split ratio, the temperature in the reaction furnace is kept

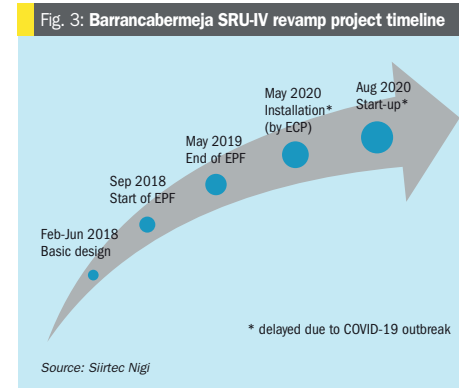
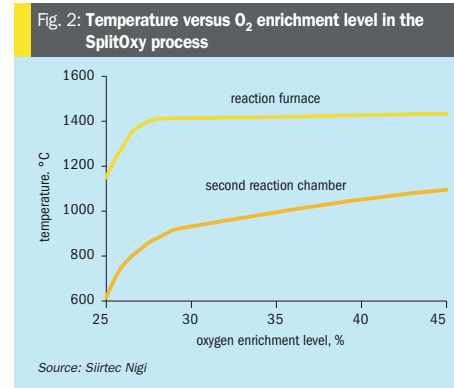

below the limit of 1,550°C regardless of the overall enrichment level; this arrangement allows the process control to be extremely safe and simple: only one parameter is controlled, the overall oxygen enrichment level, whilst operator intervention is limited to the optimum and safe operating window.

### SRU revamp at Barrancabermeja refinery

Before oxygen enrichment was used to increase capacity, the SRU-IV operating in the Ecopetrol Barrancabermeja refinery had a maximum throughput of 52 t/d of liquid sulphur. The unit was originally licensed in 2004 by Siirtec Nigi and built in 2007.

The unit consisted of a thermal stage (reaction furnace) followed by three catalytic stages. As common for smaller units, the waste heat boiler and three sulphur condensers were integrated into one piece of equipment.

The original SRU-IV was able to treat both acid gases coming from the amine regeneration unit (AAG) and from sour water stripper unit (SWSG), which contain both H<sub>2</sub>S and ammonia.

The purpose of the revamp was to achieve the following targets:

- increase the total capacity to 90 t/d using atmospheric combustion air plus oxygen, with the flexibility to still operate with combustion air only at original capacity;
- improve operation to achieve a high service factor without decreasing overall sulphur recovery.

Additional project constraints included:

- minimising layout requirements to fit new equipment within the existing plot area;
- minimising capex.

Table 1: Summary of oxygen enrichment technologies

Category	Enrichment level*	Expected capacity increase	Enrichment main feature
Low	< 26 vol-%	up to 40%	oxygen supply skid
Medium	26 to 36 vol-%	up to 70%	oxygen burner
High	> 36 vol-%	from 70% to 100%+	additional revamp measures

\*Enrichment reference level may vary depending on acid gas composition and presence of ammonia.

CONTENTS

What's in issue 391

COVER FEATURE 1

Long term oil and gas output

COVER FEATURE 2

The market for sulphuric acid

COVER FEATURE 3

SRU oxygen enrichment

COVER FEATURE 4

Materials for sulphuric acid service

SULPHUR  
ISSUE 391  
NOVEMBER-DECEMBER 2020

BCInsight

Southbank House, Black Prince Road  
London SE1 7SJ, England

Tel: +44 (0)20 7793 2567

Fax: +44 (0)20 7793 2577

Web: www.bcinsight.com

www.bcinsightsearch.com

Table 2: Upgrade of SRU-IV components at Barrancabermeja refinery

	Items replaced	New Items
Equipment	Acid gas KO drum; Thermal reactor package, including burner, reaction furnace and WHB.	Oxygen skid (piping, valves, filters, etc.).
Piping and valves	Acid gas feed lines to burner; Steam/water lines from/to WHB (+30% steam production); Sulphur rundown lines.	Oxygen feed lines to burner and second reaction chamber
Degassing section	New external sulphur degassing box (Siirtec Nigi's proprietary design) to replace the existing degassing towers in the sulphur pit.	
Layout	Same plot area required for thermal reactor Package.	Additional space for oxygen skid.

Source: Siirtec Nigi

Therefore, Siirtec Nigi's approach to the design of the revamped SRU was based on two principles:

- minimising the impact on the existing plant by maintaining the original design gas flow throughput in the equipment downstream of the thermal stage;
- keeping the operating temperature of the reaction furnace at a reasonable level.

Among several alternatives, a solution based on the SplitOxy scheme was selected, with a target overall enrichment level of 36 vol-%, in order to meet project objectives and plant requirements.

Table 2 summarises the results from assessing the existing facilities, in accordance with the revamp objectives.

**Scope of the revamp – schedule**

Siirtec Nigi's key role in revamping the SRU-IV is shown in Fig. 3.

After the EPF phase (engineering, procurement and fabrication of SRU-IV critical

equipment) Siirtec Nigi was also involved in the detailed engineering development, which started on December 2018, and the site services for the overall revamp activities (erection and dismantling).

The new equipment was successfully installed and started-up on August 2020 and has been continuously operating using oxygen since then.

**Siirtec Nigi's new thermal reactor package**

A new thermal reactor package (including burner, reaction furnace and waste heat boiler) based on the Siirtec Nigi's SplitOxy technology was designed to comply with the project requirements.

The reaction furnace is equipped with the advanced Siirtec Nigi oxygen enrichment burner (Fig. 4), which is an evolution of the oxygen burner for Claus units developed in early 2000s.

The acid gases are injected into the main burner in the same way as an air-based

Claus burner. The oxygen is injected into dedicated ports surrounding the acid gas gun in order to achieve an oxygen concentration gradient – thus a temperature gradient – in the reaction furnace, mitigating the thermal stress on the refractory lining.

The compact burner design allows it to be fitted in the new reaction furnace without impacting its overall dimensions.

The new reaction furnace is a conventional two-zone thermal reactor with internal second zone gas distributor and quite similar to the original unit. It has been customised to fit with the new Siirtec Nigi's oxygen burner and to ensure adequate refractory/ferrules design and selection to comply with the new process conditions.

In the revamped SRU, the new waste heat boiler is still provided as the first pass of a multi-function heat exchanger.

As already mentioned, in the SplitOxy process some of the oxygen is injected into the rear end of the WHB first pass, thus postponing part of the H<sub>2</sub>S conversion to a colder, but still very active, zone.

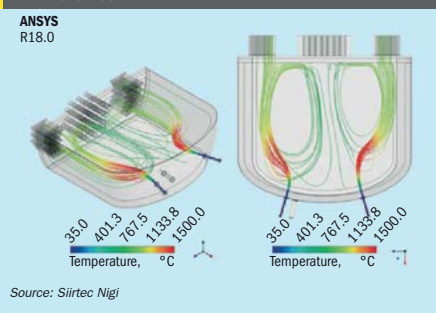

Fig. 4: Oxygen enrichment Claus burner



Fig. 5: New waste heat boiler (rear view)

Fig. 6: CFD temperature streamlines in second combustion chamber



Source: Siirtec Nigi

Fig. 7: Siirtec Nigi process specialist assisting operations remotely



PHOTO: SIIRTEC NIGI

Rather than directing the hot gas from the WHB first pass to a separate reaction chamber, the rear channel of the new multi-pass waste heat boiler was designed to provide the right residence time and to become the second reaction chamber.

Compared to the original equipment, the new WHB features the same tube size, number and length. However, the layout of tubes and channels of the five passes has been modified to fit the new second reaction chamber (Fig. 5).

A dedicated burner is not required, as only oxygen lances are used to introduce oxygen into the second reaction chamber.

Computational fluid dynamic (CFD) modelling was used to support the design of the WHB second reaction chamber (Fig. 6), factoring in the number of oxygen lances and their diameter, length, position and orientation. The model was also used to validate the residence time in the chamber and the adequacy of refractory material selection.

**A new (remote) start-up**

After the basic design and EPF phases, Siirtec Nigi provided site assistance to the client for the following activities:

- operator training;
- supervision on dismantling and erection activity;
- pre-commissioning, commissioning and start-up technical assistance.

As both installation and commissioning were supposed to take place during plant turnaround, the initial schedule was set for March 2020.

While training sessions were held on-schedule on February 2020 at Ecopetrol premises in Colombia, the supervision of

dismantling and erection was only partially executed as the site activities, due to the Covid-19 outbreak, came to a sudden slowdown.

The global pandemic situation made it clear that a new approach to site assistance had to be developed.

Due to the Colombian safety rules and travel restrictions, Siirtec Nigi passed on the technical knowledge for the Ecopetrol's team to safely and properly handle the remaining site works.

Installation and pre-commissioning activities were conducted by Ecopetrol at site during April-June 2020, while Europe was facing the Covid-19 lockdown.

In the commonly agreed path forward, Siirtec Nigi meanwhile prepared full step-by-step procedures for commissioning and start-up of critical equipment (such as the thermal reactor package, degassing box and oxygen supply skid), drawing attention to relevant operating and safety issues.

The start-up activities at site were then planned to be carried out by the refinery personnel under Siirtec Nigi's remote live assistance on a daily basis.

Start-up of the revamped SRU-IV was finally scheduled for the end of July 2020, with a duration of approximately 16 days.

**The hardware, software and people**

The key persons involved in the start-up phase of the revamped SRU-IV were:

- Siirtec Nigi's process specialist, located in Milan;
- Ecopetrol focal point for SRU start-up, located in Barrancabermeja.

Due to the difference in time zones, daily assistance was scheduled from 1 pm to

9 pm (CET). The schedule for meetings, communications and continuous remote assistance was adapted to engage the two teams from different time zones.

An online communication channel was set up to organise daily calls, briefing on previous day site activities and updates about project schedule.

Through this channel, the DCS historical trends of process variables, gas compositions and any other data were promptly made available to the Siirtec Nigi specialist (Fig. 7).

**Dry-out and heating-up operations**

By the time Siirtec Nigi joined the remote support activities on July 26, 2020, the SRU-IV was completing the commissioning activities and final checks before proceeding with reaction furnace dry-out and heating-up.

The dry-out was accomplished by burning fuel gas in the reaction furnace burner with excess of combustion air, as required to remove any moisture contained in the refractory after installation.

During the temperature ramp-up, external skin temperature measurement of the WHB rear channel was used (Fig. 8) to ensure that water was also completely removed from the castable refractory installed in the second reaction chamber.

As typically recommended for first start-ups, a stoichiometric run (i.e. fuel gas stoichiometric combustion with air and smothering steam) was also conducted at the end of the heating-up procedure in order to get the necessary experience and to consolidate air/fuel and steam/fuel ratios as well as the relevant control valves positions.

CONTENTS

What's in issue 391

COVER FEATURE 1

Long term oil and gas output

COVER FEATURE 2

The market for sulphuric acid

COVER FEATURE 3

SRU oxygen enrichment

COVER FEATURE 4

Materials for sulphuric acid service

SULPHUR  
**ISSUE 391**  
NOVEMBER-DECEMBER 2020

**BCInsight**

Southbank House, Black Prince Road  
London SE1 7SJ, England  
Tel: +44 (0)20 7793 2567  
Fax: +44 (0)20 7793 2577  
Web: www.bcinsight.com  
www.bcinsightsearch.com



### Acid gas cut-in

After unit heating-up was concluded, the acid gas cut-in procedure was started.

Once in stable conditions after cut-in, a portion of amine acid gas (AAG) was routed to the reaction furnace second zone as required to reach an operating temperature suitable for treating sour water stripper (SWS) gas.

Despite high acid gas bypass flow to the second zone of the reaction furnace (around 30%), the maximum temperature that could be achieved in the first zone of the reaction furnace was 1,190°C compared to a target temperature of 1,250°C.

Ecopetrol's team at the site confirmed that the AAG feed to the unit had a lower H<sub>2</sub>S concentration than the one specified for the design. In fact, the AAG fed to SRU-IV was a blend of different acid gases from two amine regeneration units, one of them delivering a 91 vol-% H<sub>2</sub>S rich acid gas and the second one only a 67 vol-% H<sub>2</sub>S acid gas.

Actual estimated composition of AAG to the SRU-IV compared to the design figures is shown in Table 3.

The leaner gas composition had a greater amount of CO<sub>2</sub> and H<sub>2</sub>O, which resulted in a low reaction temperature. To compensate for this, besides adjusting the acid gas flow rate to the reaction furnace second zone, oxygen enrichment operation was also required.

### Oxygen cut-in

In principle, oxygen cut-in is intended to be performed when the plant is operating with combustion air only, near to its

Table 3: Estimated acid gas composition to SRU-IV as of 7 Aug 2020

Component, vol-%	Design	Actual
H <sub>2</sub> S	92.06	75.0
H <sub>2</sub>	0.08	-
H <sub>2</sub> O	7.83	12.0
CO <sub>2</sub>	-	13.0
C <sub>1</sub>	0.016	-
C <sub>2</sub>	0.008	-
C <sub>3</sub>	-	-
NH <sub>3</sub>	-	-
<b>Total</b>	<b>100.0</b>	

Source: Siirtec Nigi

maximum hydraulic limit and with a minimum oxygen flow rate in order to ensure a smooth transition.

Following Siirtec Nigi indications, oxygen cut-in was performed with a calculated initial overall enrichment level of about 33 vol-%.

As expected, oxygen cut-in caused an increase in reaction furnace temperature to about 1,250°C in 30 minutes (see Fig. 9).

This modest temperature increase is consistent with SplitOxy scheme behaviour.

After cut-in, oxygen enrichment controller was finally adjusted to the nominal figure (36 vol-% overall oxygen enrichment). The unit was kept running in stable conditions; Siirtec Nigi remote support was concluded on August 11, 2020.

### A new quest for higher flexibility

H<sub>2</sub>S-lean acid gases (like those used for the start-up of the SRU-IV in Barranca-bermeja refinery) do not allow the proper

temperature for ammonia destruction to be reached in the reaction furnace when treating sour water stripper gas with atmospheric combustion air only.

Operating a Claus unit with AAG and SWS gas under these conditions can be detrimental for downstream equipment since non-destroyed ammonia may form deposits of solid salts (ammonium sulphate, ammonium bisulphate, ammonium sulphide) at cold locations of the plant, such as condenser outlets.

In this regard, oxygen enrichment provides the benefit to increase reaction temperature by significantly reducing the amount of inert gas involved in the process.

In the SplitOxy scheme, overall oxygen enrichment and oxygen split ratio to second reaction chamber are carefully defined to enable the unit capacity increase while limiting the reaction furnace temperature at reasonable values.

Despite being designed with this target, the process still offers the flexibility to adjust the operating parameters when facing an unexpected reduction in H<sub>2</sub>S content from acid gas feed.

To illustrate this, Fig. 10 shows the temperature trends in both the reaction furnace and second reaction chamber at different oxygen enrichment levels and split ratios.

At fixed oxygen split ratio to the second reaction chamber, the effect of the overall enrichment on the reaction furnace temperature in the SplitOxy scheme is generally negligible, whereas it has a tremendous impact on plant hydraulics.

On the other side, at fixed overall enrichment level there is a negligible effect on the plant performance (recovery

Fig. 10: Overall enrichment versus temperature at different oxygen split ratios

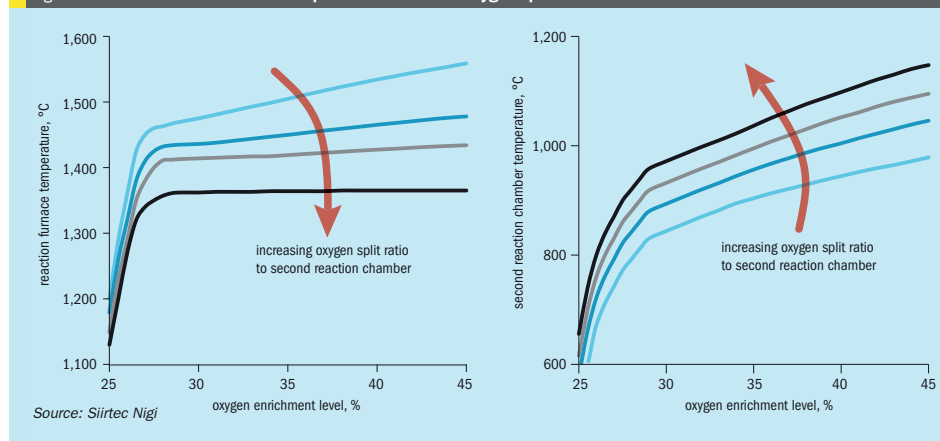

Source: Siirtec Nigi

and hydraulics) due to variations in oxygen split ratio, whereas it has a tremendous impact on the temperature envelope in the RF-WHB assembly.

The lower the oxygen split to the second reaction chamber the higher the reaction furnace temperature. Also, the lower the oxygen split to the second chamber the higher is the effect of overall enrichment on the reaction furnace temperature, similar to the behaviour of a conventional oxygen enrichment burner.

The SplitOxy scheme still offers the flexibility to operate with reduced H<sub>2</sub>S content, compared to design conditions, in the acid gas feeds by properly selecting a new oxygen split level to the second combustion chamber in order to enhance the effect of

overall enrichment on the reaction furnace temperature.

Adjusted oxygen split levels must be thoroughly evaluated against oxygen system rangeability and the overall temperature/conversion envelope once the new composition is determined.

### Summary

The SplitOxy novel dual combustion process scheme developed by Siirtec Nigi allows Claus plants to be designed for high-level enrichment without the risk of high temperature in the reaction furnace and has added operational advantages such as simple operating control, thanks to the embedded fixed oxygen split ratio.

The process can be applied in new units or as a retrofit to existing units.

When revamping an existing SRU with the target to increase the sulphur processing capacity, the economic advantages of the SplitOxy solution should be looked at in terms of number of items to be replaced and the relevant impact on layout.

Siirtec Nigi's SplitOXY technology has also recently been supplied to another refinery in Italy, to improve operability and reliability of its original SRU without changing the unit sulphur capacity. It started up successfully in June 2020<sup>1</sup>.

### Reference

1. Scilla D., Costanzi R.: "An Italian job", Hydrocarbon Engineering (Oct 2020).

Fig. 8: WHB rear channel skin temperature measurement

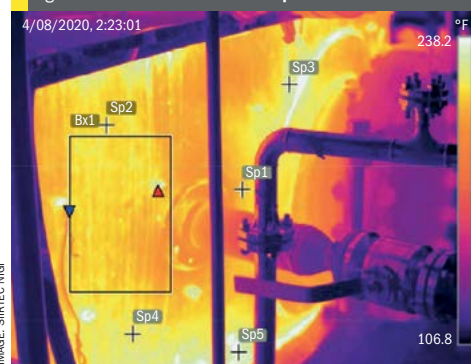
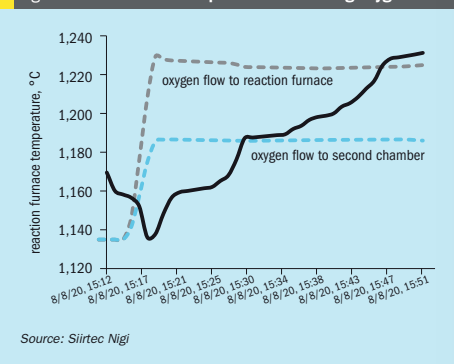

Fig. 9: Thermal reactor temperature trend during oxygen cut-in



Source: Siirtec Nigi

### LINDE / NESTE CORP.

## Low level oxygen enrichment – field trial experiences and a new Claus unit application

B. Schreiner (Linde) and P. Wiik (Neste Corp.)

Air has been used as the oxidant in Claus units since the 1930s, but today there is a clear trend to use at least moderate amounts of supplemental oxygen to enhance operational flexibility and plant reliability. Especially in refineries, applying low-level O<sub>2</sub> enrichment (process air containing up to 28 vol-% oxygen) has gained considerable acceptance and importance.

Low-level O<sub>2</sub> enrichment is characterised by O<sub>2</sub> injection into the Claus process air upstream of the Claus furnace, while at the same time reducing the flow of process air. As shown in Fig. 1, increasing the oxygen content in the process air while maintaining the original quantity of oxygen delivered, comes with ever more reduction of the nitrogen content. Respective curves

show that this effect is most pronounced at low enrichment levels which e.g. explains that even low-level O<sub>2</sub> enrichment typically allows for substantially enhanced feed throughput. Moreover, virtually all effects observed can be attributed to the reduced amount of inert gas being sent through the Claus unit, coming with increased reaction temperatures in the Claus furnace, higher

### CONTENTS

What's in issue 391

### COVER FEATURE 1

Long term oil and gas output

### COVER FEATURE 2

The market for sulphuric acid

### COVER FEATURE 3

SRU oxygen enrichment

### COVER FEATURE 4

Materials for sulphuric acid service

residence time in the reaction stages, increased  $\Delta T$  in the catalytic Claus reactors and less reheating effort (energy/fuel saving) in general.

At present, probably up to 150 Claus units have implemented low-level  $O_2$  enrichment, an indication of the ease in which it can be physically implemented; i.e. in terms of hardware only the oxygen supply chain has to be realised ( $O_2$  source, control unit and injector). Implementation of the latter into the air pipe is the only point where the Claus installation must be modified. Low-level  $O_2$  enrichment is therefore not only a low investment solution for a revamp, it also lends itself to performing field trials in advance of an envisioned implementation; such trials can be easily carried out as all the equipment necessary can be rented from a gas company and then simply removed afterwards (a typical trial set-up is shown in Fig. 2).

Many operators have already opted for trials to compare the performance of actual routine operation (air-only) with  $O_2$ -enriched operation under different  $O_2$ -enrichment levels and load conditions; i.e. at the individual Claus unit revealing the effects and limitations of oxygen use. This is particularly useful e.g. for burner and waste heat boiler performance or ammonia ( $NH_3$ ) destruction efficiency, which are difficult to predict by simulation. Such trials provide reliable performance data for further planning of oxygen application. Over the last two decades, Linde has partnered with many refineries to carry out field trials, most of them in Europe.

Linde also provided the preparation steps such as case analysis and tailor designed and built the respective  $O_2$  injectors (see Fig. 3), assuring fast and homogeneous gas mixing, which is of high importance.



Fig. 2: Mobile oxygen supply chain based on liquid oxygen.

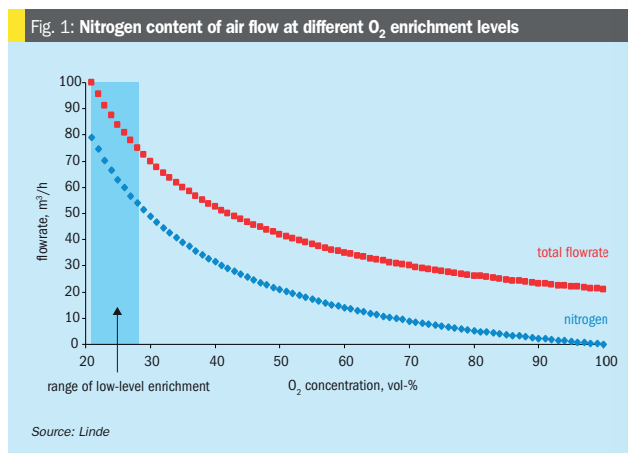

### Operating experience at Neste

One example in case showing many facets of low-level  $O_2$  enrichment application are the results of the long-standing cooperation between Linde and Neste, which operates two refineries in Finland – a smaller one at Naantali, organisationally attached to the major production complex near Helsinki at Porvoo (crude oil capacity: respectively 3 and 10.5 million t/a). At the latter refinery four Claus trains (4 x approx. 130 t/d) are operated and SWS-gas is added to the acid gas feed. Motivated by considerations about a future load increase and a temperature goal of minimum 1,250°C in the Claus furnace to be achieved by means other than co-firing, which had produced soot, Neste decided on a field trial at one of these Claus trains. In 2013 the trial run at design load and beyond was performed smoothly within one week

and a consistent data set was produced allowing four different modes of low-level  $O_2$  enrichment operation to be compared with air-only operation, the latter with and without co-firing of fuel. The trials showed that at the maximum low-level  $O_2$  enrichment level of 28 vol-%, the feed throughput can be increased by approximately 30%, an improvement which is not unexpected when compared to results from other refineries. The trial showed that the application of co-firing in air-only mode at reasonably high plant load (near to design) is clearly inferior to low-level  $O_2$  enrichment application in many aspects. With co-firing, appreciably higher process gas volumes are generated according to the stoichiometry of fuel combustion by air, thus reducing the plant capacity. At comparable Claus furnace temperatures and at a moderate  $O_2$  enrichment level of 24 vol-%, the residual  $NH_3$  content was found



Fig. 3: Oxygen injectors OXYMIX™, tailor designed for Neste's Porvoo refinery.



Fig. 4: Claus unit at Neste's Naantali site.

to be about 60% less than when applying co-firing in air-only operation. In addition, due to fuel savings at different consumers all the way down from the Claus furnace to the incinerator, low-level  $O_2$  enrichment also turned out to be the most favourable option as regards the economics. Accordingly, immediately after these trials Neste decided to implement low-level  $O_2$  enrichment at all four Claus units. Operation with oxygen started up in 2016 and has been in permanent use ever since, i.e. also when no additional acid feed has to be processed. The new operating strategy was well received by the operators in the control room who experienced smoother plant operability with low-level  $O_2$  enrichment, a general trend observed at other refineries as well.

### Oxygen enrichment plus co-firing at very low load

Compared to Porvoo, at Naantali refinery the Claus situation and history of oxygen application has been very different. Here, only one Claus unit is operated (Fig. 4), also equipped with EuroClaus like the Claus units in Porvoo, but less than half their size. Back in 2006 Neste was expecting additional Claus feed in the near future and implemented low-level  $O_2$  enrichment using oxygen supply, control and injection hardware provided by Linde. However, the feed load increase never materialised, and the plant was typically operated in air-only mode at around half of its design capacity, including SWS gas processing. In 2011, the Naantali refinery invited Linde to perform  $NH_3$  sampling and measurements in air-only

mode compared to different low-level  $O_2$  enrichment levels. As expected, the results showed that with increasing low-level  $O_2$  enrichment level and correspondingly rising temperature, as well as prolonged residence time in the Claus furnace, the efficiency of  $NH_3$  destruction can be enhanced significantly<sup>1,2</sup>. This came as no surprise as all previous  $NH_3$  measurements at other sites had shown the same trend.

At Naantali, the residual  $NH_3$  found in the process gas at constant feed load conditions was as follows: 330 ppmv (air-only) vs 105 ppmv (25%  $O_2$  enrichment) vs 75 ppmv (26.5%  $O_2$  enrichment). Soon after seeing the results of the  $NH_3$  measurements, Naantali started to apply low-level  $O_2$  enrichment on a permanent basis with the main goal of achieving a Claus furnace temperature of minimum 1,300°C to minimise  $NH_3$ -related issues<sup>2</sup>. However, in 2017 the thermo-catalytic cracker was decommissioned, thus reducing the acid gas baseload for the refinery and since then on recurring occasions the Claus feed load has dropped considerably and low-level  $O_2$  enrichment was stopped as it was approaching its limitation under pronounced turn-down conditions; i.e. when the Claus furnace temperature is comparably low as "fuel" ( $H_2S$ ) input is decreased at constant heat loss. Here gas velocities of Claus feed and combustion air are already low and  $O_2$  enrichment would aggravate this situation by even further decreasing process air flow; this in turn would move the hot flame ever nearer to the burner tip, thereby jeopardising material integrity. Mainly due to this reason and until only recently, application of  $O_2$  enrichment was generally not recommended

for low-load operation and operators apply other means for temperature increase, in particular co-firing of hydrocarbons. Even though this measure comes with appreciable disadvantages such as increased risk of soot generation, it is frequently applied in turn-down situations, i.e. can be viewed as 'state-of-the-art'.

In the Porvoo field trials, the combination of co-firing and low-level  $O_2$  enrichment was inferior to low-level  $O_2$  enrichment only application – but this was at high load conditions. So, faced with the recurring low-load situations at Naantali where soot had already been found in the Claus unit after co-firing of refinery gas, Neste's engineers decided to review this approach again; they investigated whether, if using a comparably moderate fuel amount together with oxygen, promising high furnace temperature (still aiming for 1,300°C) at reduced risk of soot generation, it would be feasible to keep the original oversized Claus burner (design: 2,800 kg/h acid feed).

Supported by Linde, the licensor Comprimio and the burner supplier Duiker they found a solution which included downsizing some of the equipment, e.g. flow valves for air and oxygen supply. Naantali refinery started to apply the combined fuel/oxygen concept in 2018 in pronounced low-load situations which sometimes go down as low as 430 kg/h acid feed, i.e. to a turn-down rate of 15%<sup>2</sup>.

At Naantali,  $O_2$  enrichment in refining was established as a vital part of a new concept for mastering low-load operation; i.e.  $O_2$  use at Claus units further broadened its versatility, meeting operational challenges ranging from extended feed load all the way down to low load situations.

At present Neste applies low-level  $O_2$  enrichment at all Claus units of both refinery sites on a permanent basis, thereby confirming the observation by Brimstone (2019) that "Improved reliability has emerged as the number one goal for most sulphur and amine plant operators".

### References

- Schreiner B.: "O<sub>2</sub> enriched vs. air-only operation at Claus units – Field tests are teaching Lessons (especially in view of ammonia destruction)"; 2012 Sulphur Conference Preprints, pp. 123-142, Berlin, (Oct 2012).
- Dahlman J., Schreiner B.: "Low-load Claus Operation mastered by Oxygen Enrichment plus Co-Firing – Experiences from NESTE Refinery"; 2020 Virtual CRU Sulphur + Sulphuric Acid Conference, (Nov 2020).

What's in issue 391

COVER FEATURE 1

Long term oil and gas output

COVER FEATURE 2

The market for sulphuric acid

COVER FEATURE 3

SRU oxygen enrichment

COVER FEATURE 4

Materials for sulphuric acid service



BLASCH PRECISION CERAMICS

# Optimised VectorWall™ geometries for higher front zone Claus reaction furnace temperatures

U. Parekh

The reaction furnace (RF) is the most important equipment component in the sulphur recovery unit (SRU) since it is where about two thirds of the feed hydrogen sulphide is converted to elemental sulphur. The RF also plays a critical role in the processing of hydrocarbons, ammonia and BTEX (benzene, toluene, ethylbenzene and xylene) that often constitute a portion of the feed and if not adequately destroyed can have a serious deleterious impact downstream in the SRU. Overall, achieving these goals requires the careful calibration of the time, temperature and turbulence (the 3Ts of combustion) in the RF.

The residence time which is set by the RF volume and total flow rate (process feeds, combustion air/oxygen and possibly fuel gas) must be adequate for the myriad reaction mechanisms to reach completion or equilibrium as the case may be. Good mixing (turbulence) along the entire length of the RF is required to make sure that the reactants "see" each other and there is no stratification of the feed or combustion air such that conversion of the H<sub>2</sub>S to sulphur or contaminant destruction is compromised. This is particularly important in front/side split operations where some of the amine acid gas (AAG) bypasses the burner and is fed downstream in the RF to achieve higher temperatures in the front zone of the RF. Finally, temperature plays an absolutely critical role in the RF, especially in achieving the desired temperature for BTEX and ammonia destruction which require temperatures of 1,050 and 1,300°C respectively. Achieving these temperatures is predominantly set by the

strength of the AAG feed but can also be impacted to some degree by burner design and the aforementioned front/side split operation.

Reaction furnace internals such as checkerwalls and choke rings are commonly used in a RF to improve mixing, increase the temperature in the front zone and protect the waste heat boiler tubesheet to varying degrees. An enhancement to these structures that is much more structurally robust and provides additional benefits including better mixing and higher residence times and front zone temperatures is the Blasch VectorWall™ (Fig. 1). These have been demonstrated to provide higher capacities, better flame stability, better contaminant destruction and much longer run lengths compared to conventional systems (Sulphur, March-April 2018). In the context of the 3Ts of combustion, this section focuses on temperature and the various methods used to influence this extremely critical parameter in the reaction furnace and the complementary role of the VectorWall.

Lean acid gas feeds offer a significant challenge in achieving stable combustion and contaminant destruction in the RF. Fuel gas co-firing, combustion air/process gas preheating, oxygen enrichment and high intensity burners are used singly or in combination to achieve the desired RF temperature. Table 1 depicts the qualitative impact of these schemes in terms of the capital and operating costs related to their implementation and their impact on SRU capacity and carbon dioxide emissions. The exact impact is unique to each

SRU and dependent on the specific feed compositions, flow configuration and burner and RF internals.

The Blasch VectorWall has been shown to increase the front zone RF temperature as seen in Fig. 2, which compares the temperature before and after a VectorWall revamp of an SRU at a refinery in Asia. It can be seen that the Zone 1 temperature increased by about 75-100°C after the revamp. This was key to solving the problem of ammonia destruction and the deposit of ammonium salts downstream that were plaguing the refinery prior to the revamp. Blasch has since focused on how the geometry of the VectorWall tiles can be optimised to further enhance temperature increases in the RF front zone while also minimising the pressure drop across the wall. For example, the geometry can be designed to provide full shielding of the flame, further minimising radiation heat loss from the front zone and hence enhancing front zone temperatures.

The main driver for oxygen enrichment of SRUs since the inception of this technology in the mid-1980s has been achieving capacity increase in the sulphur capacity without having to build costly new SRUs. Technologies exist for oxygen concentrations ranging from mid 20% to 100%, at which level the capacity of an SRU can be more than doubled. An especially important benefit of oxygen enrichment is that it also significantly increases the RF temperature thus providing much better ammonia/BTEX destruction while also reducing or eliminating the need for front-side split operation and air/feed preheating. By



Fig. 1: Blasch VectorWall™

Table 1: Qualitative impact of various temperature enhancement methodologies

	Capital costs	Operating costs	Capacity	CO <sub>2</sub> emissions
Fuel gas co-firing	▲	▲▲	▼▼	▲▲
Air/process gas preheating	▲	▲		
Oxygen enrichment	▼▼	▲▲▲	▲▲▲	▼▼
High intensity burners	▲▲			
RF/TOX internals VectorWall™	▲	▼	▲	▼

Source: Blasch

Fig. 2: Reaction furnace temperature

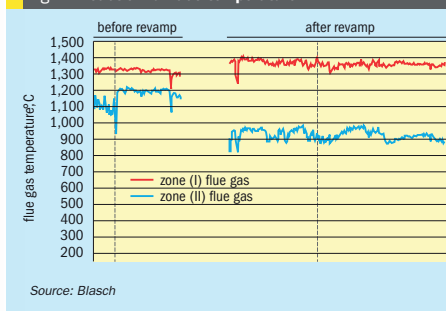

increasing front zone RF temperature as illustrated, the Blasch VectorWall also provides the same temperature enhancement benefits and thus can be used synergistically to optimise oxygen-based operation. Fig. 3 illustrates how a potential 8 to 20% reduction in oxygen consumption can be realised from the revamp of an O<sub>2</sub>-based SRU with a VectorWall. This offers signifi-

Fig. 3: Oxygen optimisation with VectorWall™ temperature enhancement

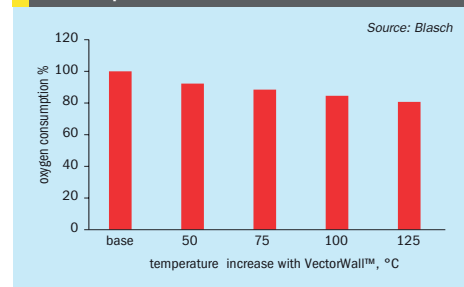

cant operational savings while also providing the additional intrinsic benefits such as better downstream mixing, beyond that achievable by a burner, and superior residence times for more reliable operation.

Another scenario of interest in the context of RF temperature is the ability to cut fuel gas co-firing rates with a VectorWall revamp and still achieve the same

desired temperatures. Very importantly, this also helps provide a significant capacity increase since each mole of reduced fuel gas firing results in a reduction of 11 moles of flue gas through the process. For a 500 t/d SRU, a front zone temperature increase of 100°C and fuel value of \$3/million Btu, energy savings of over \$250,000 per year are realised.

RAMESHNI & ASSOCIATES TECHNOLOGY & ENGINEERING

## Recovering H<sub>2</sub>S and CO<sub>2</sub> from waste streams

M. Rameshini and S. Santo

Some refinery residuals, gases, or materials that until recently would have typically been disposed of as waste materials or waste streams are now required to be recovered in the form of useful products to support new environmental regulations.

Recently, Rameshni & Associates Technology & Engineering (RATE) has been working on a project to control SO<sub>2</sub> and CO<sub>2</sub> emissions in Europe. The technologies used in this project are unique, and use proprietary designs patented by RATE.

Recovered H<sub>2</sub>S is converted to sulphur in a sulphur recovery unit using oxygen enrichment technology. The recovered CO<sub>2</sub> is compressed and sent to the RATE proprietary CO<sub>2</sub> liquefaction unit for further purification before being reinjected or used in other applications such as a transport medium for conveying solid waste, a pressure medium for the lock hopper system, seal gas for screw feeders or for stripping gas as used in this project.

This project faced many challenges regarding the design of the sulphur recovery unit and the acid gas removal section due to

the different feed compositions and impurities to these units.

Waste management plants require a quench system, COS/HCN hydrolysis, waste water treatment, AGRU, SWS, SRU, and CO<sub>2</sub> removal.

The flow diagram in Fig. 1 represents the configuration of the project for major units.

In the COS/HCN hydrolysis section, COS and HCN will be catalytically converted into H<sub>2</sub>S, CO<sub>2</sub> and NH<sub>3</sub> according to the following hydrolysis reactions:

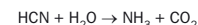
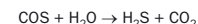

In the CO shift reactor, CO is converted to H<sub>2</sub> according to the water gas reaction:

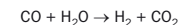

The gas stream from the hydrolysis section flows to the acid gas removal (AGR) unit where a physical solvent like Selexol or similar is used. In the AGR unit, the treated gas containing high CO<sub>2</sub> is sent to the CO<sub>2</sub>

liquefaction unit to purify the CO<sub>2</sub> product further. The acid gas stream from the AGRU is sent to the sulphur recovery unit.

A slip stream of CO<sub>2</sub> is used as the stripping gas for the process condensate stripper to strip the H<sub>2</sub>S. This scheme is also a proprietary design and unique for this application.

The SWS and condensate stripper comprises two separate stripper columns: the process condensate stripper and the NH<sub>3</sub> stripper.

The first treatment step is the removal of sour gases and volatile components in the process condensate stripper. The liquid phase of the process condensate flash drum is preheated and fed to the stripper column in between the upper and middle packing. The process condensate stripper column consists of two sections. In the upper section, CO<sub>2</sub> stripping gas is utilised to remove H<sub>2</sub>S and to minimise the stripping of NH<sub>3</sub>. In the lower section, volatile components and CO<sub>2</sub> are removed by means of uprising steam. Any dissolved carbonates are thermally decomposed. The stripped water is routed to the NH<sub>3</sub>

CONTENTS

What's in issue 391

COVER FEATURE 1

Long term oil and gas output

COVER FEATURE 2

The market for sulphuric acid

COVER FEATURE 3

SRU oxygen enrichment

COVER FEATURE 4

Materials for sulphuric acid service

SULPHUR  
ISSUE 391  
NOVEMBER-DECEMBER 2020

BCInsight

Southbank House, Black Prince Road  
London SE1 7SJ, England  
Tel: +44 (0)20 7793 2567  
Fax: +44 (0)20 7793 2577  
Web: www.bcinsight.com  
www.bcinsightsearch.com

stripper where NH<sub>3</sub> is removed and mixed with H<sub>2</sub>S from the other stripper before being routed to the sulphur recovery unit.

As already mentioned, the design includes COS/HCN hydrolysis however, there is still some HCN and COS than is not fully hydrolysed flows to the AGRU unit and eventually reaches the sulphur recovery unit. HCN can be washed as well as combusted in the reaction furnace and an additional feature is provided in the TGTU unit to hydrolyse all the remaining of COS.

There are a number of units in this plant, including the sulphur recovery unit, which require oxygen enrichment. In gas plants and refineries, oxygen enrichment technologies are used to expand the sulphur recovery capacity or to reduce the number of trains in gas plants. Oxygen enrichment raises the flame temperature by eliminating the diluent effect of nitrogen in air. An economical source of oxygen is the key in this case.

However, in waste recovery or waste management plants the sulphur recovery units are designed to boost the temperature to destroy the impurities entering the SRU. Therefore, even with 100% oxygen enrichment, neither staged combustion nor recycling are required to maintain the temperature of the refractory, single combustion is adequate.

Carbonyl sulphide (COS) requires hydrolysis to convert it to hydrogen sulphide to improve emissions and overall sulphur recovery. Traditionally, if titanium dioxide-based catalyst is used in the first Claus reactor, about 98% of the COS will be hydrolysed, the remainder being hydrolysed in the tail gas hydrogenation reactor.

But sometimes, owing to different feed compositions from the upstream units, it may be required to have a separate COS hydrolysis reactor. In summary, the following units were considered for this project.

- The acid gas removal scheme used Selexol physical solvent or similar.
- The SWS and condensate stripper is a unique design where CO<sub>2</sub> is used as the stripping gas.
- The design of the sulphur recovery unit is based on 100% oxygen enrichment and single combustion.
- The tail gas unit contains an additional reactor for COS hydrolysis and to process one of the feed streams directly to maintain a high temperature in the SRU.
- The tail gas unit is designed to recycle the quench overhead to the acid gas removal unit, whereby the tail gas amine portion is eliminated and zero sulphur emission is achieved.

Fig. 1: Major units of the waste management plant

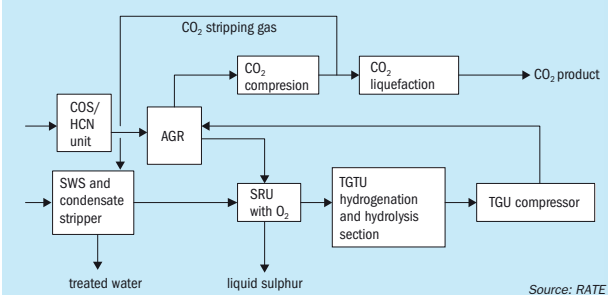
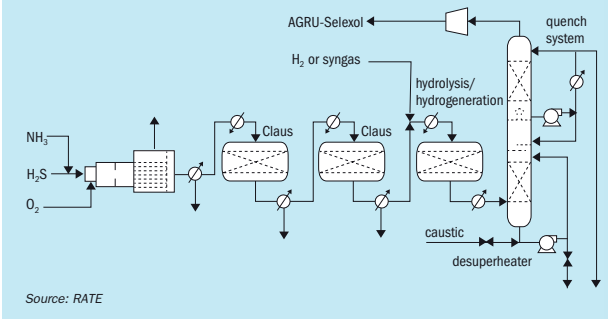

Fig. 2: The sulphur recovery unit



Detailed description

The block diagram in Fig. 2 represents the sulphur recovery with 100% oxygen enrichment plus the hydrogenation reactor, hydrolysis reactor and the quench system. The tail gas treating unit does not need an amine section, instead the quench overhead is recycled back to the AGRU unit through a compressor where H<sub>2</sub>S and CO<sub>2</sub> are separated and as a result there is no SO<sub>2</sub> emission from the SRU/TGU.

If not properly destroyed, hydrocarbons in the acid gas feed often cause carbon laydown on the catalyst and the generation of undesired high concentrations of COS and CS<sub>2</sub>. In addition, ammonia in the acid gas feed often causes deposition of complex ammonia/sulphur salts in cooler parts of the plant. These undesired phenomena can cause unscheduled plant shutdowns, reduce sulphur recovery and shorten catalyst life. Oxygen enrichment raises the reaction furnace temperature which ensures

complete destruction of heavy hydrocarbons and ammonia, reduces the formation of COS and CS<sub>2</sub>, and shortens the gas residence time required to destruct contaminants.

In case of lean acid gas feed contaminated with high levels of heavy hydrocarbons, Oxygen enrichment offers an inexpensive and simple solution to circumvent this otherwise unsolvable problem that requires costly processing technology.

The oxygen burner has proved to be very effective in destroying ammonia and hydrocarbons in Claus plants. Outside of its application in Claus plants, oxy-fuel burners are widely used in the metals and minerals and in the chemical and refining industries to burn a wide range of fuels, including gases, liquids, and pulverised solids. One of their most attractive features is their ability to burn heavy residual hydrocarbons cleanly.

Two major effects in using oxygen or oxygen-enriched air in place of air for combustion are higher temperatures and higher flame speeds. The degree of change

THREE MEET-UPS • THREE MONTHS • ONE COMMUNITY

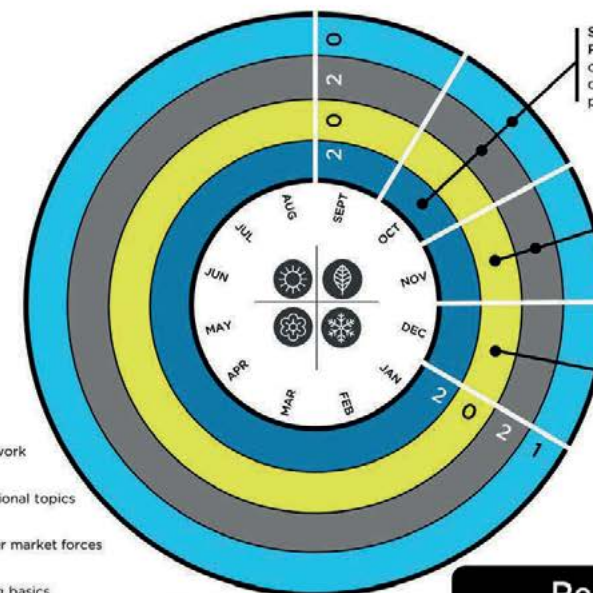

**SULPHUR INDUSTRY PAST, PRESENT, FUTURE** connecting the dots, over the decades and across geographies, in preparation for the industry's future

**SULPHUR PLANT EMISSIONS** beyond SO<sub>2</sub>...a balancing act with CO, NO<sub>x</sub> and CO<sub>2</sub> footprint

**SULPHUR PLANT CORROSION** a practical approach toward mitigating risks across various operating modes

- Community Building strengthening the network
- Technical Spotlight deep dive into key regional topics
- Commercial Drivers supply/demand + other market forces
- Training sour oil/gas processing basics

Register Today!  
www.universulphur.com/MESPOON

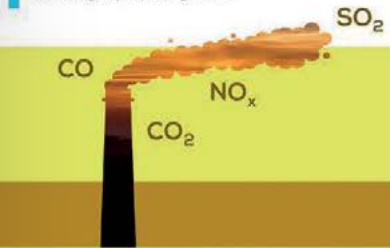

A Holistic Take on Sulphur Plant Emissions

beyond SO<sub>2</sub>... a balancing act vs. CO<sub>2</sub> footprint and CO emissions

NOV. 17  
6.00 Houston • 12.00 UK • 16.00 UAE

- Hear from:
- World-renowned sulphur researchers
  - Sulphur-specific combustion experts
  - Specialized catalyst suppliers
  - Environmental/regulatory officials



Corrosion Considerations for the SRU Operator

a practical approach toward mitigating corrosion risks across various operating modes

DEC. 15  
6.00 Houston • 12.00 UK • 16.00 UAE

- Hear from:
- World-renowned SRU corrosion experts
  - Distinguished operators of world-class SRUs from around the World
  - Specialized equipment suppliers

CONTENTS

What's in issue 391

COVER FEATURE 1

Long term oil and gas output

COVER FEATURE 2

The market for sulphuric acid

COVER FEATURE 3

SRU oxygen enrichment

COVER FEATURE 4

Materials for sulphuric acid service

SULPHUR ISSUE 391 NOVEMBER-DECEMBER 2020

BCInsight

Southbank House, Black Prince Road London SE1 7SJ, England  
Tel: +44 (0)20 7793 2567  
Fax: +44 (0)20 7793 2577  
Web: www.bcinsight.com www.bcinsightsearch.com



Fig. 3: Control and burner management system for SRU with O<sub>2</sub> enrichment

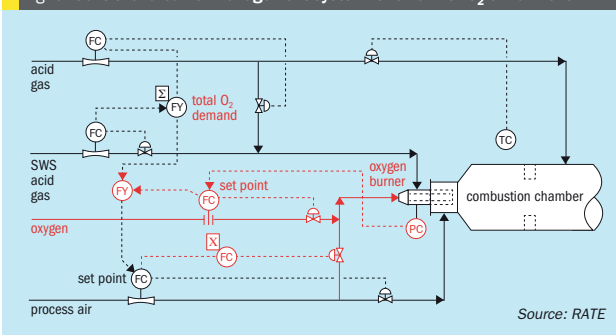

depends on the degree of oxygen enrichment, but in the case of pure oxygen, temperatures may increase by 1,050°C and flame velocities by ten times in round numbers. The combination of these two effects is to produce a hotter, shorter, more intense flame much better suited to the rapid destruction of combustible materials.

The destruction of individual feed components in a Claus unit cannot be considered in isolation, since there is considerable molecular interaction. Both hydrogen sulphide and ammonia dissociate quite readily and the higher the temperature, the higher the level of dissociation. The result is that when oxygen is used, the hydrogen level in the reaction furnace increases greatly compared to that achieved in air-based systems. Most of this hydrogen will subsequently recombine with sulphur in the waste heat boiler (WHB), including hydrogen produced from ammonia dissociation. The ammonia must effectively be burned, even if the mechanism of destruction is initially dissociation, in order to preserve the Claus Stoichiometry downstream of the WHB.

It can be speculated that the hydrogen remaining in the gas after the WHB will be higher if the level in the reaction furnace before the boiler is higher. This must be true if the quench rate in the boiler remains constant. The effect may be small however, and in the case of up rating with oxygen, where the WHB sees a higher load, a fall in quench rate may reduce it still further.

The AGRU is designed to separate the H<sub>2</sub>S, which is sent to the sulphur recovery unit to produce sulphur as the product. The CO<sub>2</sub> is also separated and compressed to be used as the product. The SWS and the condensate tower also remove H<sub>2</sub>S and ammonia and send them to the sulphur recovery unit.

The sulphur recovery unit receives two acid gas streams containing H<sub>2</sub>S and NH<sub>3</sub>. As we know, the ammonia can be destructed in the thermal section, but unfortunately the H<sub>2</sub>S entering the SRU is very lean and cannot establish an adequate combustion temperature of at least 1,050°C to achieve the successful burning of ammonia with air-only operation. This project is therefore designed with 100% oxygen enrichment in single combustion. Also on account of the lean acid gases, even with Ti catalyst in the SRU converters, the significant COS and CS<sub>2</sub> produced in the reaction furnace would not be fully converted to H<sub>2</sub>S in addition to the feed compositions contained COS.

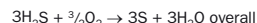
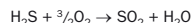

Ammonia, which can form undesirable sulphur compounds, must also be destroyed in the combustion process:

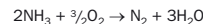

The sulphur recovery unit is designed with a thermal section featured 100% oxygen enrichment and two catalytic reactors.

The tail gas stream from the last condenser flows to the hydrogenation reactor in the tail gas treating unit containing low temperature CoMo catalyst and using indirect steam reheaters.

H<sub>2</sub> and CO present in the tail gas from the Claus units reacts with the sulphur vapour and SO<sub>2</sub> in the tail gas over a catalyst bed to form H<sub>2</sub>S. The hydrogenation catalyst also promotes the hydrolysis, i.e. reaction with water, of COS and CS<sub>2</sub> to form H<sub>2</sub>S. Hydrogenation and hydrolysis

reactions for the four primary sulphur constituents are as follows:  
Hydrogenation reactions

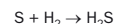

Hydrolysis reactions

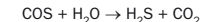
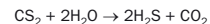

CO does not react directly, but is converted to H<sub>2</sub> over the catalyst by the water shift reaction:

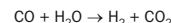

These reactions are exothermic.

The outlet of the hydrogenation reactor cools off and then flow to the proprietary design hydrolysis reactor. The outlet of this reactor flows to the quench system.

Tail gas is desuperheated in a bed of grid-type packing in the lower section of the column by a circulating water stream pumped by the desuperheater circulating pump. This water is maintained alkaline to protect against any SO<sub>2</sub> breakthrough from the hydrogenation reactor. The desuperheater section is initially filled with a 10-wt% caustic (NaOH) solution. This solution quickly reacts with the CO<sub>2</sub> in the tail gas to form a sodium carbonate/bicarbonate (Na<sub>2</sub>CO<sub>3</sub>/NaHCO<sub>3</sub>) buffer solution.

Any SO<sub>2</sub> that breaks through from the hydrogenation reactor will react with the solution to form sodium sulphite/bisulphite (Na<sub>2</sub>SO<sub>3</sub>/NaHSO<sub>3</sub>). Periodically, as the carbonate/bicarbonate is depleted, a portion of the solution is drained to the spent caustic system and replaced by fresh caustic solution. The spent caustic is cooled in the spent caustic cooler and then sent off-plot for disposal.

The gases exiting the quench column are normally routed to the Selexol unit through a compressor.

Back-up incineration is also provided for abnormal conditions where the quench overhead flows to the incinerator instead of recycling back to the AGRU.

Carbon capture usage and storage (CCUS) is not only an important to mitigate industrial CO<sub>2</sub> emissions and reduce environmental footprint, it also enables valuable and cleaner burning gas previously used for EOR, for power generation desalination and industrial usage.

Many oil companies recognise CCUS technologies in tandem to tie in with

gas conditioning within an overall circular carbon economy policy taking advantage of the technologies to reduce, recycle, reuse and remove CO<sub>2</sub>, as well as employing artificial intelligence and big data, to reduce emissions by monitoring energy consumption and optimising operations.

The sulphur recovery design using high purity oxygen enrichment has exclusive criteria and safety considerations. One of the most important features is to design the control system and the burner management system to establish a safe environment for the operation team at the facility. The diagram in Fig. 3 represents the control system and the burner management system where oxygen enrichment has been added to the design of the sulphur recovery unit.

Safety concerns around SRU oxygen enrichment are two-fold:

- the introduction of oxygen to a new plant area;
- changes in design and equipment from a conventional air-based SRU.

The following safety features should be incorporated into the DCS and burner management systems.

- Oxygen and natural gas should be interlocked so that they are not introduced to the burner at the same time.
- The oxygen line should be equipped with automated double isolation safety blocks and bled to a safe location (similar to natural gas).
- Suitable material should be selected for the oxygen line, valve and any other instrumentation.
- A proper shutdown system should be provided to prevent equipment damage during oxygen enrichment operation at high temperatures.

There is no doubt that the presence of oxygen requires operators to exercise additional safety precautions; but operators and designers are gaining more experience and higher comfort level in handling oxygen in hydrocarbon rich areas. The necessary materials, safeguards and operating procedures for handling oxygen are well defined and understood. Furthermore, the oxygen distribution system should be designed with minimum inventory near combustibles.

Fig. 4 shows the process flow diagram for the thermal section using 100% oxygen enrichment. The catalytic section is not shown because it is the same as air operation scheme.

The advantages of using oxygen enrichment are to establish stable combustion

Fig. 4: SRU thermal section using 100% oxygen enrichment

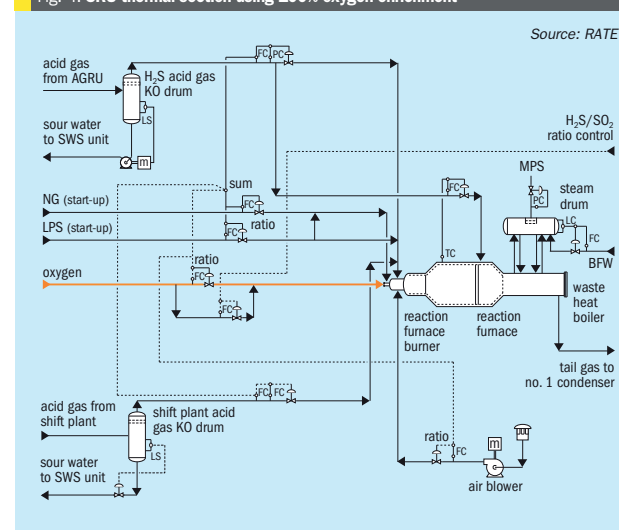
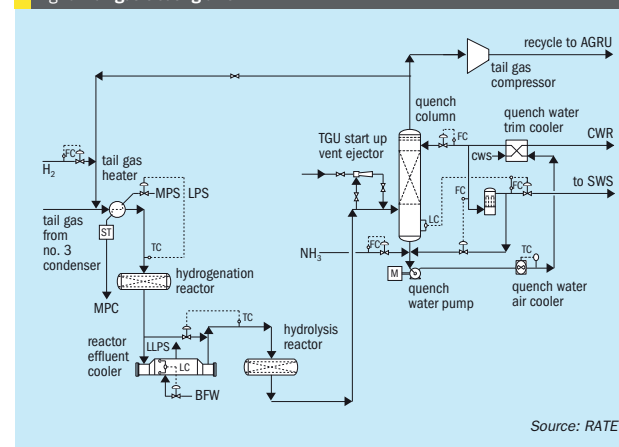

Fig. 5: Tail gas treating unit



temperature where NH<sub>3</sub> can be fully destructed in the reaction furnace burner. Oxygen enrichment reduces the plot area among other impurities that enter the sulphur recovery unit. Oxygen enrichment will reduce the size of the equipment, resulting in lower capital costs and also improves the sulphur recovery efficiency. The advantages for the tail gas unit when using oxygen enrichment in the SRU is that the equipment for tail gas treating will also be smaller, resulting in lower

capital cost and again better performance. Oxygen enrichment reduces the plot area required for SRU capacity expansion and for operating facilities limited by plot space, oxygen enrichment may be the only viable option. The oxygen cost is a factor that should also be considered.

Fig. 5 shows the tail gas treating unit with hydrogenation and hydrolysis reactor and the quench system.

FLUOR ENERGY & CHEMICALS

# Fluor's Oxygen Enhanced Claus Carbon Dioxide Recovery Process (OEC<sup>2</sup>RP)

T. K. Chow

Weather change occurs in many places around the world causing icebergs to melt quicker; sea level to rise, unusual high daily temperatures, heavy rainstorms and tornados. These all occur partly due to the increasing presence of carbon dioxide (CO<sub>2</sub>). Unfortunately, a high percentage of the CO<sub>2</sub> emitted to the atmosphere is related to emissions from oil and gas, chemical and power industries.

To mitigate these undesired weather changes, CO<sub>2</sub> emissions need to be reduced from these industries. During the last couple of decades, much research effort has been focussed on recovering CO<sub>2</sub> from emission streams such as acid gases from amine absorber overhead effluents and tail gas effluents from Claus tail gas treating unit amine absorber overheads. However, it is known to the industry that recovering CO<sub>2</sub> is a very energy intensive exercise. Due to the acidic nature of this gas stream, expensive materials have to be used to mitigate corrosion issues on equipment. Thus rendering all processing plant utilising CO<sub>2</sub> Recovery technologies with high capex and opex requirements.

Fluor's patent-pending Oxygen Enhanced Claus Carbon Dioxide Recovery Process – OEC<sup>2</sup>RP was invented to provide a state-of-the-art cost effective method to recover CO<sub>2</sub> from gas effluent of the Claus tail gas treating unit amine absorber overhead.

This carbon dioxide recovery technology is designed specifically for recovering CO<sub>2</sub> from the SRU/TGTU facility of gas plants, although it is applicable for any SRU/TGTU facilities. Gas feeds to Claus sulphur recovery units typically contain a very high percentage of CO<sub>2</sub> in gas plants, thus rendering recovery from the Claus tail gases more economical and worthwhile.

This technology works well with oxygen enrichment technology in SRU/TGTUs and offers opportunities around a SRU/TGTU revamp to improve the profitability of a facility while meeting environmental objectives. The flexibility of these technologies provides substantial economic and process advantages for a wide range of applications over competing solutions.

Fluor's patented COPE<sup>®</sup> oxygen enrichment Claus Technology can provide an economical solution for the expansion of existing facilities and a more cost effective solution for new facilities, while providing significant process benefits. COPE I<sup>®</sup> and COPE II<sup>®</sup> oxygen enrichment Claus technology have low life cycle costs (low capex and opex) and have been implemented in over 80 sulphur recovery facilities worldwide from small scale to world scale plants.

## Oxygen enrichment Claus operation

Why consider implementation of oxygen enrichment technology into the Claus operation for existing SRU/TGTUs? Oxygen enriched Claus operation offers the following benefits to enhance the current SRU/TGTU operation in terms of operation flexibility and reliability:

- enhances the Claus reaction furnace (RF) operating temperature;
- potentially mitigates requirements of fuel gas co-firing in attaining sufficient temperature for achieving complete BTEX and ammonia destruction;
- the enhanced RF operating temperature facilitates dissociation of H<sub>2</sub>O molecules to form H<sub>2</sub>, which in turn facilitate the hydrogenation reactions in the TGTU hydrogenation reactor with much more excess H<sub>2</sub> compared to Claus air operation. This benefit is especially welcome for gas plant operation as usually a gas plant facility does not have another source of H<sub>2</sub> which might be needed for the hydrogenation reactor operation during unexpected mal-operation of upstream processing units;

- requires minimum modifications of existing equipment especially for gas plant SRU/TGTUs;
- reduces overall volumetric gas flow through the entire SRU/TGTU facility, thus enhances acid gas processing capacity;
- reduces pressure drop across the entire SRU/TGTU facility, thus might mitigate the need of higher amine acid gas battery limits inlet pressure to the SRU facility;
- enhances Claus sulphur recovery efficiency;
- minimises equipment size of new SRU/TGTUs, thus reduces capex and opex of new SRU/TGTUs;
- reduces Plot Sizes of new SRU/TGTUs. Oxygen enrichment technology is especially beneficial to gas plant SRUs because amine acid gas feed to the existing SRUs is lean in H<sub>2</sub>S and usually contains some amounts of BTEX, which usually requires higher temperature, say >1,100°C for complete destruction. By eliminating the potential requirement of fuel gas co-firing, potential carbon deposition in the first catalyst bed due to cracking of fuel gas will be mitigated. This technology also reduces volumetric gas flow rate due to the absence of nitrogen in the pure oxygen thus helps any pressure drop issues across the plant and provides increased acid gas processing capacity.

Table 1 provides comparisons between air Claus operation and various levels of oxygen-enriched air Claus operation.

As indicated in Table 1, for the SRUs in this gas plant study, even operating with 35% O<sub>2</sub>-enriched air, the RF temperature is still only 2,020°F (1,104°C), but the volumetric gas flow is reduced by 25%. The

Table 1: Air Claus vs O<sub>2</sub>-enriched air Claus

Claus reaction furnace operation	Reaction furnace operating temperature, °F (°C)	Volumetric gas flow rate
100% Air, with fuel gas co-firing	2,020 (1,104)	120%
100% air	1,900 (1,038)	100%
28% O <sub>2</sub> -enriched air	1,970 (1,077)	80%
35% O <sub>2</sub> -enriched air	2,020 (1,104)	75%
100% O <sub>2</sub>	2,150 (1,177)	55%

Source: Fluor

oxygen burner may be the only equipment item that needs to be replaced when implementing this technology. While operating with 100% O<sub>2</sub>, the RF temperature is only about 2,150°F (1,177°C). The required equipment modification is most likely just the RF oxygen burner and possibly the first sulphur condenser. However, the volumetric gas flow rate is reduced by more than 45% providing lots of spare or additional acid gas processing capacity.

## Oxygen Enhanced Claus Carbon Dioxide Recovery Process (OEC<sup>2</sup>RP)

While implementing 100% O<sub>2</sub> for the Claus operation, not only is the Claus tail gas flow rate to the TGTU greatly reduced, there will also be no or only a very minute

amount of N<sub>2</sub> present. As a consequence, the main components in the feed gas to the TGTU amine absorber will be H<sub>2</sub>, H<sub>2</sub>S, H<sub>2</sub>O and CO<sub>2</sub>. Highly selective amine such as formulated MDEA could be used to remove the H<sub>2</sub>S component to less than 10 ppmv in the amine absorber overhead effluent prior to being vented to the atmosphere via a thermal oxidation/stack.

In addition, sterically hindered amines such as ExxonMobil's Flexsorb™ SE and SE Plus and BASF/ExxonMobil's OASE<sup>®</sup> Sulfex™ have the capability to slip over 95% CO<sub>2</sub>, yielding an amine absorber overhead effluent gas containing less than 10 ppmv of residual H<sub>2</sub>S but over 95% of all the CO<sub>2</sub> in the absorber feed gas.

One of the process configurations of Fluor's Oxygen Enhanced Claus Carbon

Dioxide Recovery Process involves the conversion of hydrogen to water via oxidation and quenching/cooling of the hot gas stream. For a 100% oxygen enriched SRU/TGTU, the product from the OEC<sup>2</sup>RP is a very pure carbon dioxide stream capable of being used for EOR after compression and dehydration. The purity of the CO<sub>2</sub> stream is determined primarily by the purity of the oxygen used for oxygen enrichment. For instance, if a 99.5% oxygen stream with 0.5% nitrogen is used, the CO<sub>2</sub> stream from the OEC<sup>2</sup>RP will be >98% CO<sub>2</sub> on a dry basis. Fig. 1 is a simplified block flow diagram showing the how OEC<sup>2</sup>RP is integrated into a sulphur recovery facility.

Table 2 shows the product streams of a SRU/TGTU operating with 100% O<sub>2</sub> from a case study for one of Fluor's clients. The absorber overhead effluent will mainly contain about 80% CO<sub>2</sub>, 13% H<sub>2</sub>, and 7% H<sub>2</sub>O. Followed by proven processing steps of removing the H<sub>2</sub> and H<sub>2</sub>O components, the product CO<sub>2</sub> will have a purity of over 99+%. The H<sub>2</sub> component could be recovered as a product stream via known processes such as membrane separation, PSA or a cryogenic system depending on the end users of the CO<sub>2</sub> and H<sub>2</sub>.

The key benefits of OEC<sup>2</sup>RP are much lower capex and opex relative to conventional investment and energy intensive CO<sub>2</sub> recovery processes. Due to its simplicity OEC<sup>2</sup>RP also has a small footprint which is a significant advantage in space constrained facilities.

## References

1. Wong, V. Sanchez, A., Flowers, J., Chow, T., Sikorski, D., Roussakis, N.: "key design features for a successful SRU operation implemented with oxygen enrichment technology", Brimstone Sulphur Recovery Symposium (2010).
2. Flowers, J., Wong, V., Chow, T., Flood, T., Fedich, R.: "10,000 MTD Shah Gas Development tail gas treating complex: Why FLEXSORB™?", Brimstone Sulphur Recovery Symposium (2009).
3. Seagraves, J., Fedich, R. B.: "Hitting the mark", Hydrocarbon Engineering (Aug 2019).
4. McGlade, C., Sondak, G., Han, M.: "Commentary: whatever happened to enhanced oil recovery", International Energy Agency (Nov 2018).
5. Seagraves, J., and Chow, T.: "Sulfur Recovery with COPE<sup>®</sup> oxygen enrichment Claus and Flexsorb™ SE tail gas treating", MESPON Conference (2019).
6. Seagraves, J., Chow, T., and Morell, B.: "Sulfur recovery with COPE<sup>®</sup> oxygen enrichment Claus and OASE<sup>®</sup> sulfex™ in tail gas treating", Brimstone Virtual Sulphur Recovery Symposium (2020).

Fig. 1: One of the process configurations of OEC<sup>2</sup>RP

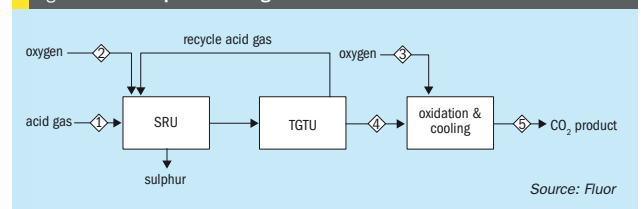

Table 2: CO<sub>2</sub> product stream of OEC<sup>2</sup>RP

Description	acid gas to SRU	O <sub>2</sub> to SRU RF	SRU tail gas to TGTU	Overhead effluent from after removal Flexsorb absorber	CO <sub>2</sub> product after H <sub>2</sub> and H <sub>2</sub> O
Stream Number	1	2	3	4	5
Components, mole %					
H <sub>2</sub>	0.00	0.00	3.19	12.40	trace
O <sub>2</sub>	0.00	100.00	0.00	0.00	0.00
N <sub>2</sub>	0.00	0.00	0.00	0.00	0.00
C <sub>1</sub>	0.20	0.00	0.00	0.00	0.00
CO	0.00	0.00	6.47	0.63	0.00
CO <sub>2</sub>	47.34	0.00	40.78	79.62	99.80+
H <sub>2</sub> S	47.17	0.00	1.61	0.00	10 ppmv
COS	0.00	0.00	0.38	0.06	0.00
SO <sub>2</sub>	0.00	0.00	0.80	0.00	0.00
H <sub>2</sub> O	4.95	0.00	46.71	7.28	trace
Molar flow, lbmol/hr	5,119.0	1,088.1	5,832.5	3,116.8	2,502.4
Standard gas flow, million std ft <sup>3</sup> /d	46.62	9.91	53.12	28.39	22.79
Temperature, °F	140	100	322	105	153
Pressure, psig	11.5	15.0	4.0	0.3	0.0

Source: Fluor

CONTENTS

What's in issue 391

COVER FEATURE 1

Long term oil and gas output

COVER FEATURE 2

The market for sulphuric acid

COVER FEATURE 3

SRU oxygen enrichment

COVER FEATURE 4

Materials for sulphuric acid service

SULPHUR  
ISSUE 391  
NOVEMBER-DECEMBER 2020

BCInsight

Southbank House, Black Prince Road  
London SE1 7SJ, England  
Tel: +44 (0)20 7793 2567  
Fax: +44 (0)20 7793 2577  
Web: www.bcinsight.com  
www.bcinsightsearch.com



# Materials for pumps, valves, and piping in sulphuric acid service

Several highly corrosion resistant materials are available today for use in handling process fluids encountered in the production of concentrated sulphuric acid. These alloys, properly selected for the operating conditions, provide the benefits of long operating life under harsh operating conditions extending the period of uninterrupted production cycles and lowering the incidence of catastrophic equipment failure. In this article, **M. J. Cooke** of Weir Minerals discusses materials of construction for pumps, valves and piping used in the production of sulphuric acid.

Pumps, valves, and piping used in the production of concentrated sulphuric acid are subjected to a media that is hot, corrosive, and often abrasive. In order to maintain performance throughout a reasonable service life, the designers of such equipment must select materials that are suitable for these fluid properties, especially for those critical components subject to high fluid velocities and turbulence.

## Design considerations

Pumps, valves and piping, respectively, pressurise, control and direct process fluids. In addition to being exposed to the corrosive effects of the fluid, this equipment is subjected to high velocities (to 30 m sec in the case of pump components) and turbulent flow behaviour that can cause wear by erosion. Further complicating the issue is the presence of entrained solids that add the potential for abrasive wear.

Pump designs require that close dimensional tolerances be maintained in order to insure maximum hydraulic efficiency and performance, particularly between impeller/casing rings, and sleeve bearing components. Valves require the same maintenance of dimensional tolerances between discs/plugs and their seating surfaces, in order to provide precise control and/or tight shut-off according to their function. The perfect material of construction for these critical components is

therefore one that resists corrosion over a usable range of acid concentration and operating temperatures, is hard enough to offer abrasion resistance when required, and has non-galling characteristics.

The selection of materials for the principal "body" components of pumps and valves (i.e. volutes and valve bodies) and piping must consider not only the potential effects of abrasion and corrosion but must have enough mechanical strength to contain the fluid pressure over a reasonable lifetime. Therefore, to build a useful and cost-effective product, the design and choice of materials must be optimised according to the nature of the fluid and the required conditions of service.

Fig. 1: Acid composition affects the concentration of hydrogen ions in  $H_2SO_4$

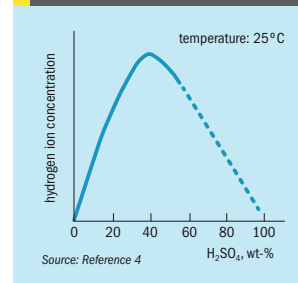

Cost effective pumps, valves and piping can be designed and supplied to meet flow sheet requirements in sulphuric acid plants and will yield good service life provided they are operated within the specified ranges. However, even the best-designed equipment will fail if process conditions are violated. The four primary causes of (unexpected) corrosion are: acid leaks, acid strength out of range, acid temperature too high, and acid flows that are too high.

## Corrosion in sulphuric acid

Modern sulphuric acid plants handle acid strengths normally in the range of 93% to 99.5% and, in some plants various concentrations of oleum. The corrosion resistance of alloys within this relatively small concentration range can vary widely and can be difficult to predict.

The corrosiveness of sulphuric acid depends upon many factors, particularly temperature and concentration. However, whereas increases in temperature generally give a corresponding increase in corrosion rate, increasing the acid concentration can increase or decrease the corrosion rate depending upon the overall conditions. This effect is attributed to the fact that the hydrogen ion concentration in sulphuric acid increases with concentration, but at higher levels decreases again, as shown in Fig. 1. The hydrogen ion concentration directly effects the rate of the

Fig. 2: Comparison of theoretical and measured anodic polarisation curves for active (Case I), active-passive (Case II), and passive (Case III) behaviour.

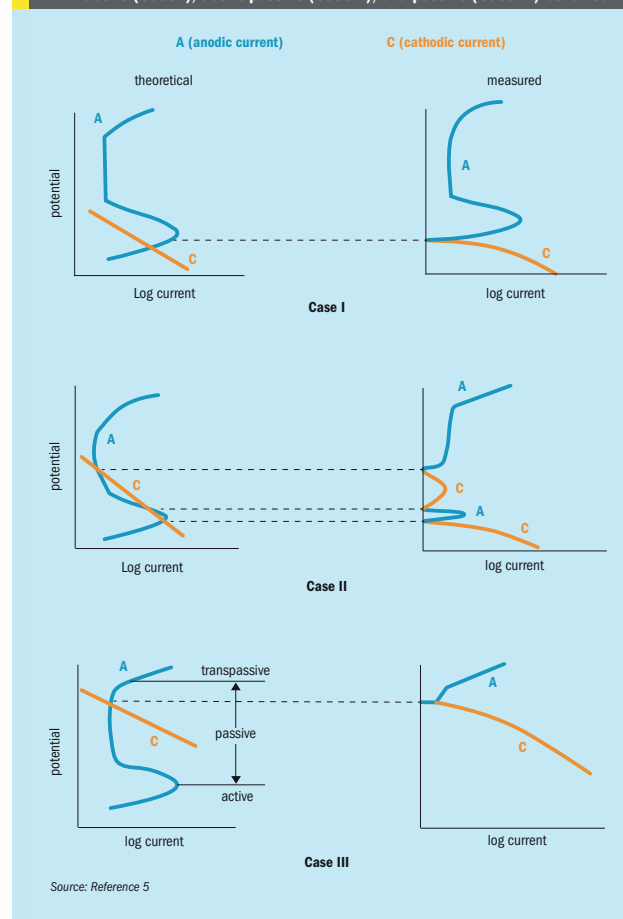

cathodic reaction and thereby the rate of anodic dissolution.

Additionally, corrosion rates can also be critically affected by other variables. The presence of oxidising or reducing impurities, the presence of chlorides, velocity effects, and galvanic effects may alter the serviceability of a particular material of construction. These influences can make predicting actual corrosion rates for a given material problematic.

The corrosion of metals in sulphuric acid is complex. However, the electrochemical behaviour of most metal alloys

falls into three categories: active, passive, or active/passive (Fig. 2). For active behaviour (Case I), the corrosion potential is in the active region and a wide range of corrosion rates is possible. For passive behaviour (Case III), the corrosion potential is in the passive region; these alloys generally passivate spontaneously and exhibit low corrosion rates. For active-passive behaviour (Case II), both active and passive behaviour is possible. This can lead to the possibility of unpredictable and erratic corrosion rates, depending on the environment.

## Cast irons

Cast iron has been used for many years in the construction of pumps, piping and other components in the manufacture of concentrated sulphuric acid. Today, gray iron, ductile iron, and several specialty irons continue to be used with good success in this service.

Like carbon steel, which is used in handling concentrated sulphuric acid at ambient temperatures under static and low velocity conditions, cast iron derives its corrosion resistance primarily from the formation of an iron-sulphate film. This sulphate film is highly protective, unless physically disturbed. The actual corrosion rate depends on the temperature, acid concentration, iron content, and flow, because these parameters determine the rate of dissolution of the protective sulphate film. However, compared to carbon steel, the higher carbon and silicon content of cast irons leads to conditions favouring superior resistance at higher velocities and elevated temperatures. Gray cast iron normally should not be used in the oleum range because of a tendency toward catastrophic cracking caused by a reaction between the free  $SO_3$  and the graphite flakes in the iron.

Lewis' L-14<sup>®</sup> iron, introduced in 1980, is used extensively in larger acid pumps and gate valve products for principal body components where high dimensional requirements are not of paramount concern for hydraulic performance (volute, elbows, discharge pipes, shaft columns and valve bodies). Alloying elements control the microstructure of the iron matrix in such a way as to provide favourable graphite dispersion. This iron resists "oleum cracking" and used in heavy-walled sections providing good service life in concentrated acid to temperatures approaching 135°C (see Fig. 3).

Fig. 3: Lewis' specialty irons relative corrosion rate 98% sulphuric acid

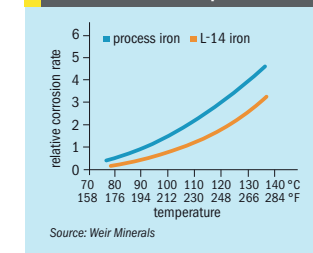

Several specialty ductile irons have been used extensively in piping around acid towers. Furnished in very heavy-walled sections, they have good ductility, and form a tough sulphate film that resists corrosion. Sizing the piping so that fluid velocities do not exceed 1.2 m/sec generally precludes erosive wear in acid piping.

### Stainless steels and nickel based alloys

The corrosion resistance of stainless steels and most nickel-based alloys is complex due to the active-passive nature of the alloys. Resistance to corrosion depends upon achieving electrochemical passivity – Case III behaviour. Passivity is achieved by the surface formation of tightly adhering, crack-free, complex oxide films that protect the underlying metal. The formation and maintenance of these oxide films require oxidising conditions. Therefore, highly aerated solutions are much more suitable than air free ones. Similarly, the presence of oxidising impurities stabilises the passive film, markedly improving the corrosion resistance. Essentially, chromium and silicon are the two elements that promote the formation and adherence of these films. In addition, corrosion resistance can be often enhanced in mildly oxidising environments, and those containing reducing impurities, by the addition of nickel, molybdenum, and copper to the alloy. Other alloying elements are then added in order to adjust the metallurgical and mechanical properties of the final alloy.

Generally, for austenitic stainless steels (304, 316 types), stable passivity is achieved at ambient temperatures in the very low and very high concentrations and in oleum. Higher austenitic stainless steels (the 20-type alloys) are usually the first considered when the sulphuric acid environment is too corrosive for 300-series stainless steels or cast iron (see isocorrosion diagram, Fig. 4). The nickel-base alloys have superior resistance up to 95% concentration because of their high alloy content. Frequently, low corrosion rates occur in both the active and the passive corrosion states. Thus, reliable corrosion behaviour is achieved over a wide range of concentrations, temperatures, and impurity levels.

The use of highly corrosion-resistant nickel-based alloys used in the critical components of Lewis sulphuric acid pumps dates back to 1925, about the time

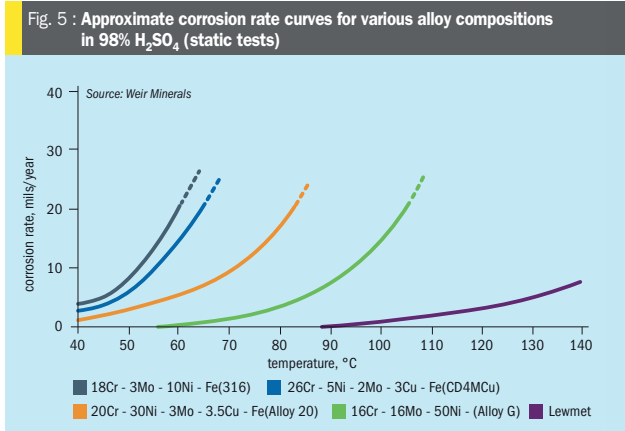
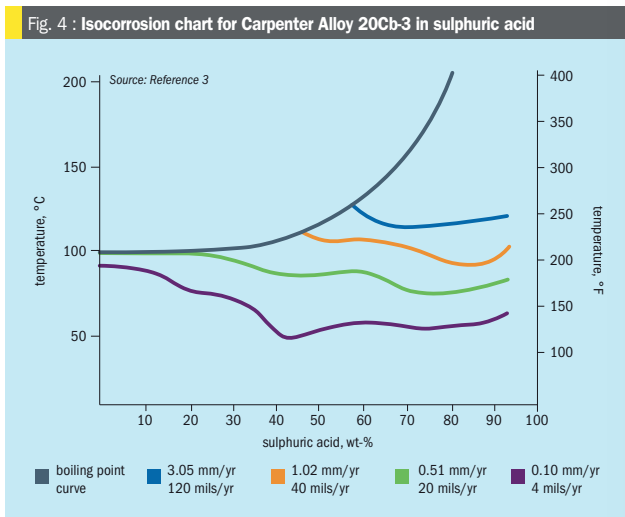

these alloys became commercially available. The nickel base permitted higher additions of the desired alloying elements as compared to iron-based alloys. The early alloy, Ni-22Cr-7Mo-6.5Cu exhibited a corrosion rate of less than 0.25 mm/y in 98% acid to 90°C with operating velocities to 30 m/sec. However, this alloy, which was fully austenitic, could not be hardened and was only available in cast form.

In 1940 Alloy 20, Fe-20Cr-30Ni-3Mo-3.5Cu was introduced. While offering utility in 98% acid to 90°C operating temperature, the resistance to corrosion-erosion

declines rapidly above this temperature. Alloy 20 is a fully austenitic alloy available in both cast and wrought form and cannot be hardened.

Lewmet® 33/44, Ni-31Cr-3Si-3Mo-3Cu, was introduced by Lewis Pump in the early 1970s. The corrosion rate of this alloy is presented in Fig. 5. This alloy also exhibits excellent corrosion resistance in 93-100% sulphuric acid and all concentrations of oleum. There is virtually no increase in the corrosion rate due to erosive wear at velocities to 30 m/sec. This alloy is hardenable to 400 BHN (45Rc) to provide

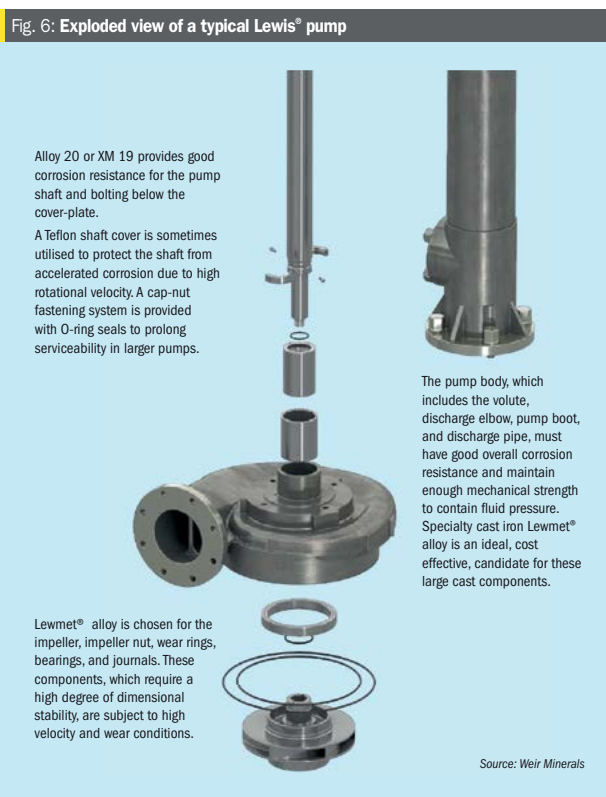

excellent galling and abrasion resistance with no detectable loss in the corrosion rate. These characteristics make Lewmet® the ideal material for use in manufacturing close clearance critical components for pump sleeve bearings and impeller/casing rings and for valve discs/plugs and seats.

Subsequent to the introduction of Lewmet® 33/44, a wrought version of this alloy was developed. Introduced as Lewmet® 66, this modification has the same corrosion resistance as its parent alloy, is available in both cast and wrought forms, but cannot be hardened.

High silicon stainless steel alloys were developed in the mid-1980s. Nominally Fe-18Cr-18Ni-5Si, these alloys possess outstanding corrosion resistance in 98% sulphuric acid to 140° C. However, the corrosion rates can increase dramatically with decreasing acid concentrations and with acid concentrations in excess of

99.5% through the oleum range. Corrosion protection is obtained by the formation of a tenacious silicon-rich film formed on the surface during initial exposure.

Chromium alloy metals are selected for use in high temperature heat recovery service with 99.5% sulphuric acid to 220°C. These alloys include austenitic and duplex stainless steels having high chromium content. However, a minor decrease in concentration at these high operating temperatures will cause high corrosion rates for these alloys, especially if exposed to high velocity conditions. Lewmet® 15, a proprietary high chromium duplex stainless steel of Lewis Pumps, has exhibited excellent corrosion resistance in heat recovery applications. It can be hardened to approximately 375 BHN (40Rc) and has shown superior resistance to weak acid corrosion as evidenced in process variable excursions in existing heat recovery systems.

Note that high silicon stainless steels are not recommended for this service.

### Selection criteria

Using a typical Lewis pump as an example (see Fig. 6), the materials of construction chosen for a given service vary according to the specific requirement of each the component parts:

Lewmet® 33/44 is chosen for the impeller, impeller nut, wear rings, bearings, and journals. These components, which require a high degree of dimensional stability, are subject to high velocity and wear conditions. Lewmet® 33/44 was specifically designed for this service.

Readily available in wrought bar form, Alloy-20 or XM-19 provides good general corrosion resistance for the pump shaft and bolting below the cover-plate. To prolong serviceability, especially in larger pumps, a Teflon shaft cover is also utilised, and a cap-nut fastening system provided with O-ring seals.

The pump body, which includes the volute, discharge elbow, pump boot, and discharge pipe, must have good overall corrosion resistance and maintain enough mechanical strength to contain fluid pressure. Specialty cast iron L-14® is an ideal, cost effective, candidate for these large cast components.

By critically assessing the most appropriate material choice for a given service condition, pumps, valves, and piping can be manufactured that not only assure adequate service life but do so in the most cost-effective manner.

### References

- Borges R. (Chas S. Lewis & Co.): "Material selection criteria for sulphuric acid and phosphoric acid equipment", Journee Espace Corrosion Conference conducted by Groupe Office Cherifien des Phosphates, Safi (28 April, 1999).
- Muller T. L. (of E.I. Dupont de Nemours & Co., Inc.): "Keeping your acid plant healthy", Sulphuric Acid Today, p. 14 Spring/Summer 2000 Issue.
- CEB-1: "The corrosion resistance of nickel-containing alloys in sulphuric acid and related compounds", Corrosion Engineering Bulletin by INCO The International Nickel Company, Inc.
- Henthorne M. (Carpenter Technology Corporation): "Corrosion Causes and Control".
- Metals Handbook Ninth Edition, Volume 13 Corrosion, ASM International.

What's in issue 391

COVER FEATURE 1

Long term oil and gas output

COVER FEATURE 2

The market for sulphuric acid

COVER FEATURE 3

SRU oxygen enrichment

COVER FEATURE 4

Materials for sulphuric acid service

SULPHUR  
ISSUE 391  
NOVEMBER-DECEMBER 2020

BCInsight

Southbank House, Black Prince Road  
London SE1 7SJ, England  
Tel: +44 (0)20 7793 2567  
Fax: +44 (0)20 7793 2577  
Web: www.bcinsight.com  
www.bcinsightsearch.com



# SO<sub>2</sub> emissions reduction using an IIoT solution

**A. Bhargav** and **A. Krishnan** of Helium Consulting Pvt. Ltd discuss how it is possible to reduce SOx emissions within the existing system setup of an oil refinery or gas plant through detailed analysis, expedited corrective actions and the use of automated algorithms in real-time, by using a digital IIoT solution to monitor, control and optimise.

**S**ulphur dioxide (SO<sub>2</sub>) is strictly regulated all over the world. One of the most difficult environmental problems facing industry is how to economically control SO<sub>2</sub> emissions. Converting SO<sub>2</sub> to sulphuric acid is one of the best options based on economic and utility considerations.

The largest source of SO<sub>2</sub> emissions is from the combustion of fossil fuels at industrial facilities, e.g. coal-fired power plants. Smaller sources of SO<sub>2</sub> emissions include industrial processes such as extracting metal from ore, and the burning of high sulphur containing fuels by various equipment.

## Approaches and strategies for SO<sub>2</sub> emission control

Various methods for SO<sub>2</sub> control are based on either the prevention of SO<sub>2</sub> pollution or end of treatment of flue gases. But small scale flue gas cleaning is often impractical and not feasible. Substitution of sulphur-containing fuels by clean fuel is desirable. Various approaches for controlling SO<sub>2</sub> emissions include:

- Use of clean fuel: This includes either switching to a fuel with reduced amount of sulphur or reducing fuel-sulphur before its firing. Since SO<sub>2</sub> emissions are directly proportional to the sulphur content of fuel, and also to the amount of fuel fired, a reduction in emissions can be achieved by switching to higher quality fuels with lower sulphur content.
- Removal of sulphur from the fuel: This includes various cleaning methods developed for desulphurising sulphur-bearing fuels prior to their firing.
- Preventing the production and release of SO<sub>2</sub> during combustion: Several technologies have been developed to

control SO<sub>2</sub> emission during combustion. The most developed are the fluidised bed combustion technologies and integrated gasification combined cycle (IGCC).

- Flue gas desulphurisation (FGD): End-of-pipe treatment is based on FGD, where flue gas is treated before it is emitted into the atmosphere via the stack. FGD technology is used to remove SO<sub>2</sub> from exhaust flue gases.
- Sulphur recovery system: The Claus process has been in use for several decades. The Claus tail gas treatment unit typically achieves close to 99% sulphur removal in refineries and gas plants.

In light of tightened regulations and necessary environmental protection, there are many options to consider. Helium Consulting experts can help to perform a thorough analysis, from emissions, to SO<sub>2</sub> removal facilities and how to operate the existing system in an optimal way to gain the most benefit.

## The Sulphur Solution

The primary objective of the Sulphur Solution is to optimise the sulphur recovery circuit and find the optimum operational parameters that enhance the performance while minimising the cost and bottlenecks for reducing SOx emission. This IIoT based technology works by capturing data and using it to provide information. The data integration and analytics produce effective, actionable business intelligence.

The IIoT-enabled digital systems with advanced analytics, help to improve decision making by aggregating data from multiple sources. The analytics help to recommend actions based on the data.

The benefits of IIoT-enabled tools include:

- decision making support and improved operation through continuous monitoring and by providing instant access to information;
- improved monitoring of energy usage helps to increase operating efficiency;
- less unplanned downtime with increased rate of asset utilisation;
- detection of efficiency losses;
- maintaining the effectiveness of control loops, controllers and models over time, so the benefits of advanced process control are sustained;
- lowering overall process risk, thus improving safety;
- reduced maintenance costs.

The IIoT-based Sulphur Solution is a proprietary software platform for sulphur systems in refineries, gas plants, the petrochemical industries etc. This high-speed, sulphur optimisation application integrates the visualisation of key performance indicators (KPIs) and process analytics. The solution combines the deep domain knowledge OT (operation technology) with IT (information technology) to offer unprecedented ability for online analysis. The solution provides an ecosystem for an integrated sulphur management system. The key components of the solution consist of the following:

- Helium's proprietary LP model for the sulphur circuit;
- a commercially available adaptive process control application and simulation/process engineering platform;
- Helium's rich dashboard with sulphur specific KPIs;
- a proprietary high speed integration platform aligned with modern high frequency big data like DCS, Historian, APC etc.

This solution intricately brings these components together to facilitate short term and long term decision making by plant personnel. By encompassing monitoring to control multiple process operations, using multiple software applications on one platform, the economics and environmental performance of an entire business can be improved.

A seamless stream of actionable insights enable the sulphur chain throughout the industry as a whole to inspect its process, providing analyses for optimization and early diagnosis of issues to prevent costly hidden upsets for several stakeholders. By having a single window, real-time actionable insights can be used to optimise the process profitably, thus syncing numerous functions under one roof. By providing extremely detailed data in real time, the IIoT can help companies understand their business processes better and, by analysing the data coming from sensors, can make their processes more efficient and even open up new revenue streams.

## Case study: A refinery digitalisation journey

Refineries are one of the larger sources of SOx emissions. The Sulphur Solution is part of the digital journey of the refinery, helping to identify gaps in the process and improve decision making.

The key challenges can be summed up by:

### Regulatory challenges

- catering to the environmental norms.

### Data challenges

- data available in a segregated manner;
- data in terms of information not available.

### Operational challenges

- identification of operational issues;
- identification of instrumental issues;
- identification of optimum operation conditions;
- optimum energy usage.

### Reporting challenges

- visualising data with a single platform;
- taking action based on data.

### The solution approach

Once the requirements based on the above challenges were determined, the solution was implemented. Helium Consulting brings together the experience as the technology implementation partner for optimisation and simulation as a cohesive eco system for an integrated sulphur management system.

The implementation findings included the following:

### Data and analytics

During the implementation phase the emission and other sulphur line data were found to be erratic. The data is obtained from various sources. It is important that the data is cleaned before it is used. This helps to remove the risk of taking decisions on data with imperfections that do not accurately represent the situation at hand.

The instrumentation error also gets captured by the software. The erratic instruments list is published by the software and appropriate actions like calibration and tuning take place by the plant maintenance team. The calibration of sulphur and SOx measuring instruments takes place at frequent intervals to remove the solid sulphur from the line and record proper measurements.

Required soft sensors were developed from the data and implemented. Some of these soft sensors are, for example, dew-point data measurements such as outlet condenser temperature measurements. A redundancy soft sensor has been developed for measuring the H<sub>2</sub>S/SO<sub>2</sub> ratio in real-time. Soft sensors inform operators and engineers in real time what is going on in their processes. Sulphur soft sensing solutions are so reliable that they are used in closed loop to improve the performance of assets.

The data model runs in the background, targeting the optimum operating point. Data points include, for example, reactor optimum temperature for proper conversion and to reduce emissions, and optimum condenser temperature to be maintained to remove elemental sulphur and prevent it from carrying over to the next reactor, thus helping to maintain reactor life.

### Unified information

The data required to monitor and operate the sulphur system was segregated throughout the plant, with multiple data at various sources like process data, lab data, advance process control data, planning data etc. The data integration combines data from multiple sources to create unified sets of information for both operational and analytical uses. The primary objective is to produce consolidated data sets that are clean and consistent and meet the information needs of different end users in an organisation.

The software integrated the data with multiple applications and layers of data

validation, AI/ML-based intelligent data analysis and KPIs generated and are visualised in the dashboard.

The Sulphur Solution enhanced the refinery's economic and environmental performance using a unified solution for the entire business process encompassing monitoring to control the operation of multiple processes using multiple software applications on one platform.

This solution can be used in units that generate or recover sulphur, e.g. ATU, SWS, SRU TGTUs. Users can access the data and obtain recommendations for appropriate operational actions.

### Benefits

The multiple application integration with its optimisation options gives the industry stakeholder an appropriate platform to make various decisions which can result in an energy reduction of 1-3%, reduced emissions by 50-400% and significantly more stable plant operations.

The Sulphur System has provided the following key benefits:

- identification of all erratic data and instruments;
- data from various sources can be combined in one place for better investigation – the sulphur dashboard is used to centralise the sulphur specific requirements;
- sulphur process optimisation help to identify the optimum value to operate;
- regular status of the sulphur units with action status sent to user for taking decision;
- significant reduction in plant SOx emissions.

### Conclusion

The Sulphur Solution can be applied in any industry where sulphur removal is an issue. Besides implementing the best sulphur control technology as illustrated, monitoring and taking corrective action at the appropriate time is very important. The Sulphur Solution is built upon cutting edge technology combined with the power of big data analysis, AI/ML and other intelligent technology.

The core pivot around which the Industry 4.0 phenomenon revolves is data and its efficient use and management. The idea of collecting data and translating it into decision making is not new but its applications under Industry 4.0 are revolutionary. ■

## Advertisers' index

**Editor:** RICHARD HANDS  
richard.hands@bcinsight.com

**Technical Editor:** LISA CONNOCK  
lisa.connock@bcinsight.com

**Contributor:** MEENA CHAUHAN  
meena.chauhan@argusmedia.com

**Publishing Director:** TINA FIRMAN  
tina.firman@bcinsight.com

**Subscription rates:**  
GBP 440; USD 880; EUR 680

**Subscription claims:**  
Claims for non receipt of issues must be made within 3 months of the issue publication date.

**Sales/Marketing/Subscriptions:**  
MARLENE VAZ  
Tel: +44 (0)20 7793 2569  
Fax: +44 (0)20 7793 2577  
marlene.vaz@bcinsight.com  
Cheques payable to BCInsight Ltd

**Advertising enquiries:**  
TINA FIRMAN  
tina.firman@bcinsight.com  
Tel: +44 (0)20 7793 2567

**Agents:**  
**Japan:** (also subscription enquiries)  
KOICHI OGAWA  
O.T.O. Research Corporation  
Takeuchi Building  
1-34-12 Takadanobaba  
Shinjuku-Ku, Tokyo 169, Japan  
Tel: +81 3 3208 7821  
Fax: +81 3 3200 2889

**Previous articles** from *Sulphur* from 1995 to the present are available digitally in PDF format. To make a purchase, or for a list of available articles, please see: [www.bcinsight.com](http://www.bcinsight.com)

**Copyright**  
*Issued six times per year, or bi-monthly. All rights reserved. No part of this publication may be reproduced, stored in a retrieval system or transmitted in any form or by any means – electronic, mechanical, photocopying, recording or otherwise – without the prior written permission of the Copyright owner.*

ISSN: 0039-4890

**Design and production:**  
JOHN CREEK, DANI HART



**Printed in England by:**  
Buxton Press Ltd  
Palace Road, Buxton, Derbyshire,  
SK17 6AE

© 2020 – BCInsight Ltd

**BCInsight**

**Published by: BCInsight Ltd**  
China Works, Unit 102,  
100 Black Prince Road,  
London SE1 7SJ, UK  
Tel: +44 (0)20 7793 2567  
Fax: +44 (0)20 7793 2577  
Web: [www.bcinsight.com](http://www.bcinsight.com)  
[www.bcinsightsearch.com](http://www.bcinsightsearch.com)

Advertiser	Page	Website
Argus Media	19	argusmedia.com
<b>BRIMSTECH CORPORATION</b>	IBC	brimstech.com
Dupont Clean Technologies	11	cleantechnologies.dupont.com
Enersul Limited Partnership	OBC	enersul.com
HUGO PETERSEN GmbH	9	hugo-petersen.de
IPCO Germany GmbH	5	IPCO.com
ITT Rheinlutte Pumpen GmbH	21	rueinhuette.de
SulGas Webinar Series	17	sulgasconference.com/econnect
Sverdrup Steel	27	sverdrupsteel.com
MESPOON Mini Meet-Ups	39	universulphur.com/MESPOON
Worley Netherland (Comprimo)	IFC	advisian.com
Worley Chematics	13	worley.com/chemetics

### Next issue: January/February 2021

- Phosphates – can China balance the market?
- Refining – dealing with the Covid crisis
- Canada's sulphur industry
- Sulphuric acid catalysts
- Solving operational problems in the SRU with simulation
- Preventing or extinguishing molten sulphur tank and pit fires

**For further information and to book advertisement space contact:**  
**Tina Firman, Publishing Director:** [tina.firman@bcinsight.com](mailto:tina.firman@bcinsight.com)  
**Tel: +44 (0)20 7793 2567 Fax: +44 (0)20 7793 2577**

**BRIMSTECH**  
CORPORATION

Welcome to  
the next ERA of  
Sulphur Solidification

forthcoming

CONTENTS

What's in issue 391

COVER FEATURE 1

Long term oil and  
gas output

COVER FEATURE 2

The market for  
sulphuric acid

COVER FEATURE 3

SRU oxygen  
enrichment

COVER FEATURE 4

Materials for  
sulphuric acid  
service

SULPHUR  
**ISSUE 391**  
NOVEMBER-DECEMBER 2020

**BCInsight**

Southbank House, Black Prince Road  
London SE1 7SJ, England  
Tel: +44 (0)20 7793 2567  
Fax: +44 (0)20 7793 2577  
Web: [www.bcinsight.com](http://www.bcinsight.com)  
[www.bcinsightsearch.com](http://www.bcinsightsearch.com)





# FOR EVERYTHING SULPHUR.

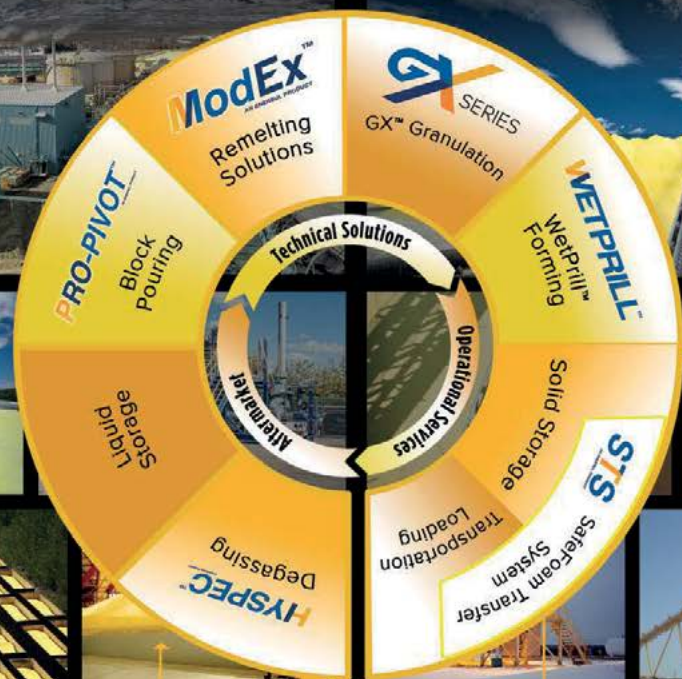

- FEED Studies
- EPC Support
- Training
- HSE Specialists
- Rail
- Ship
- Truck
- Bag

When it comes to forming, handling and moving sulphur; no one company has more hands on experience than Enersul. We offer our own ground breaking proprietary technologies, developed in house through decades of operational experience and pioneering Research and Development. We market and operate the most complete array of new and innovative sulphur technologies and services for any capacity, in any climate. Contact us today and find out how Enersul is your solution For Everything Sulphur.

[enersul@enersul.com](mailto:enersul@enersul.com)

Don't forget the next issue of **Sulphur** January/February 2020

CONTENTS

What's in issue 391

COVER FEATURE 1

Long term oil and gas output

COVER FEATURE 2

The market for sulphuric acid

COVER FEATURE 3

SRU oxygen enrichment

COVER FEATURE 4

Materials for sulphuric acid service

SULPHUR  
**ISSUE 391**  
NOVEMBER-DECEMBER 2020

**BCInsight**

Southbank House, Black Prince Road  
London SE1 7SJ, England  
Tel: +44 (0)20 7793 2567  
Fax: +44 (0)20 7793 2577  
Web: [www.bcinsight.com](http://www.bcinsight.com)  
[www.bcinsightsearch.com](http://www.bcinsightsearch.com)