

1
2
3
4
5
6
7
8
9
10
11
12
13
14
15
16
17
18
19
20
21
22
23
24
25
26
27
28
29

Welcome to our interactive version of **Sulphur** Issue 397

Please use either the buttons on the left or top right of the page to navigate your way around this interactive PDF

IMPORTANT INFORMATION:

Copyright – Issued six times per year, or bi-monthly. All rights reserved. No part of this publication may be reproduced, stored in a retrieval system or transmitted in any form or by any means – electronic, mechanical, photocopying, recording or otherwise – without the prior written permission of the Copyright owner.

Number 397

November | December 2021

SULPHUR

www.sulphurmagazine.com

Sour gas projects
Demand for sulphur fertilizers
Options for sour water stripper gas
Sulphuric acid projects and technology

CONTENTS

What's in issue 397

COVER FEATURE 1

Sour gas projects

COVER FEATURE 2

Demand for sulphur fertilizers

COVER FEATURE 3

Options for sour water stripper gas

COVER FEATURE 4

Sulphuric acid projects and technology

SULPHUR
ISSUE 397
NOVEMBER-DECEMBER 2021

BCInsight

Southbank House, Black Prince Road
London SE1 7SJ, England
Tel: +44 (0)20 7793 2567
Fax: +44 (0)20 7793 2577
Web: www.bcinsight.com
www.bcinsightsearch.com

1
2
3
4
5
6
7
8
9
10
11
12
13
14
15
16
17
18
19
20
21
22
23
24
25
26
27
28
29

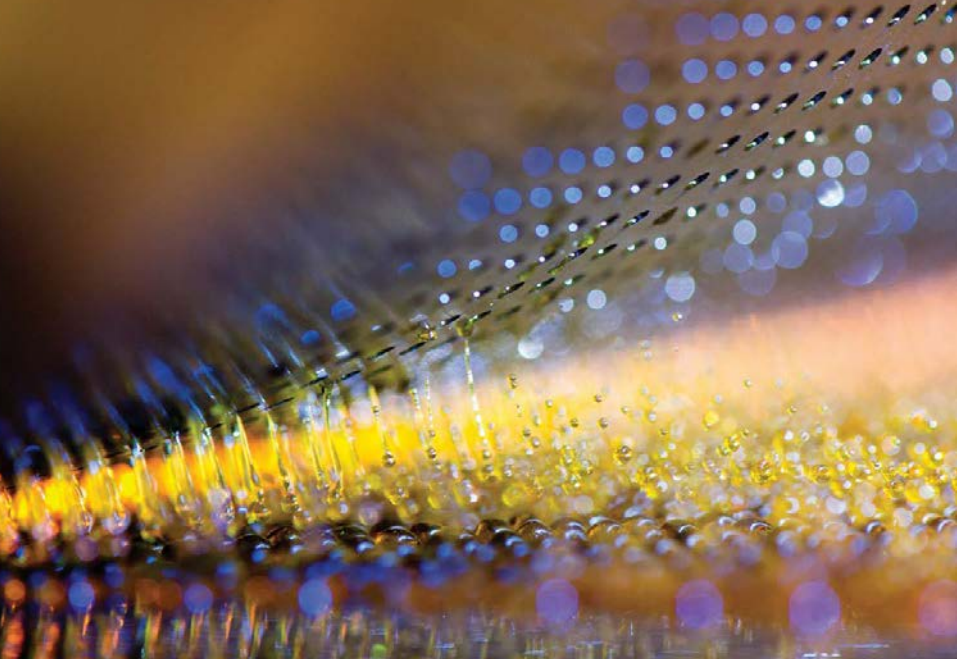

A WORLD LEADER IN SULPHUR PROCESSING AND HANDLING

End-to-end systems from receipt of molten sulphur to loading of solid material – single source supply by IPCO.

- Premium Rotoform pastillation.
- Duplex steel belts specifically alloyed to resist corrosion.
- High capacity drum granulation.
- Downstream storage – silo and open/closed stockpiles.
- Custom-built reclaimers for any location.
- Truck, rail and ship loading and bagging systems.
- Large scale block pouring.

ipco.com/sulphur



Cover: PosiNote/Shutterstock.com



9

Sulphur from sour gas

New projects will boost Middle Eastern sulphur output.



23

Moving to biofuels

Challenges of processing sour water acid gas streams.

Read this issue online at:
www.sulphurmagazine.com

Published by:
BCInsight

SULPHUR

www.sulphurmagazine.com

NUMBER 397

NOVEMBER | DECEMBER 2021

CONTENTS

- 9 Sour gas projects**
Although the number of new sour gas developments has slowed in recent years compared to the large boost of the previous decade, sour gas projects continue to be a major source of new sulphur production.
- 11 Trends in demand for sulphur fertilizers**
Sulphur is becoming an increasingly important crop nutrient, due to a combination of lower airborne sulphur emissions, the increasing prevalence of high analysis fertilizers, and higher cropping intensities.
- 11 Longer lived refractory linings**
As sulphur recovery units operate at progressively higher temperatures, creep stress in the furnace refractory lining can lead to deformation or even failure of the bricks and require the shutdown of the SRU. UK-based DSF Refractories have developed a product which minimises creep stress damage at high temperatures, for a longer-lived furnace lining.
- 14 A sustainable solution for sulphur waste**
C. Teulon of RSK reports on the research that was carried out to test whether the waste sulphur from a biological sulphur removal process could be applied in agriculture to increase the quality and quantity of crops in Iraq.
- 16 Sulphuric acid projects and technology**
Developments in sulphuric acid technology and engineering know-how are highlighted by recent project case studies from DuPont Clean Technologies, Metso Outotec and thyssenkrupp Uhde.
- 20 Sour water stripping gas processing options**
M. Rameshni and S. Santo of RATE discuss different sour water stripping gas processing options, depending on contaminants in the sour water streams and site-specific requirements.
- 23 Challenges with the transition to biofuels**
Considering the current shift to produce biofuels instead of conventional oil products, M. van Son of Comprimo discusses the impact that this may have on the ability to process the sour water acid gas streams produced in existing or new sour water strippers.
- 24 A new low-cost H₂S scavenger**
New low-cost metal oxide solid scavengers for H₂S removal from wet and dry natural gas have been developed and deployed at commercial scale. G. Alptekin, F. Kugler and M. Schaefer of SulfaTrap LLC describe the new technology and its performance.
- 26 Liquid redox going beyond the expected**
Streamline Innovations Inc. highlights some of the new developments and successful applications of the Valkyrie™ process and its redox technology, in both gas and water streams.

REGULARS

- 3 Editorial** Looking for the peak
- 4 Price Trends**
- 5 Market Outlook**
- 6 Sulphur Industry News**
- 7 Sulphuric Acid News**
- 9 People/Calendar**



CONTENTS

What's in issue 397

COVER FEATURE 1

Sour gas projects

COVER FEATURE 2

Demand for sulphur fertilizers

COVER FEATURE 3

Options for sour water stripper gas

COVER FEATURE 4

Sulphuric acid projects and technology

SULPHUR
ISSUE 397
NOVEMBER-DECEMBER 2021

BCInsight

Southbank House, Black Prince Road
London SE1 7SJ, England
Tel: +44 (0)20 7793 2567
Fax: +44 (0)20 7793 2577
Web: www.bcinsight.com
www.bcinsightsearch.com

Looking for the peak

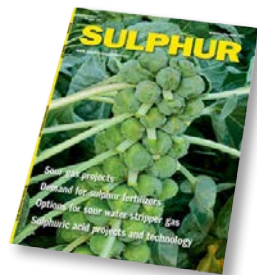

The past year has seen an extraordinary run-up in sulphur and sulphuric acid prices, the former from a low of around \$50-70/t f.o.b. in mid-2020 to more than \$100/t higher than that at the end of Q1 2021. Prices then plateaued for much of this year, but they have begun moving inexorably upwards again in the past couple of months, drawn by rapidly rising phosphate prices, and Middle East sulphur rates recently breached price levels not seen since 2012.

Sulphur depends very much upon the state of oil and gas markets for its supply, and fertilizer markets for its demand, and the former were very much impacted by the onset of the covid pandemic last year and its associated lockdowns. Part of the run-up in sulphur prices has been due to lingering supply tightness from refinery shutdowns, as well as the delay of some key supply projects, like Kuwait's Clean Fuels Project. But rising energy prices have also been behind much of the rebound in sulphur prices over the past year, as vaccination programmes lead to an easing of covid restrictions around the world and a global surge in demand for fuels. Oil prices have headed back above \$80/bbl, the highest level for eight years. And all of this has been exacerbated recently by the crunch in natural gas markets, especially in Europe and Asia.

But it is phosphate prices which have been behind much of the current pull upwards in sulphur markets. Phosphates were becalmed in 2020 like most other commodities, but the return of demand to the market has exposed relatively tight supply, with closures of Chinese domestic mono- and diammonium phosphate (MAP/DAP) due to environmental crackdowns contributing to rapidly rising prices. The natural gas price spike mentioned earlier has seen most European ammonia capacity shut down, and this, coupled with high coal prices in China has driven the ammonia content of MAP and DAP

to some of the highest prices seen for years. This was coupled in mid-October with China's decision to restrict exports of fertilizers to keep domestic consumers supplied, and has pushed DAP prices to record levels. In mid-October India's government raised its subsidies on DAP to try and keep its phosphate industry supplying farmers, which has also allowed prices to continue to rise. Phosphoric acid prices c.fr India were quoted recently at \$1,330/t – levels not seen since just before the financial crisis of 2008.

Phosphate prices like that can support high sulphur prices, but for how long? High gas and oil prices look to be with us for at least the rest of the northern hemisphere winter, but phosphate demand can be more sensitive to high prices. Still, Mosaic said at the start of November that 90% of its fourth quarter sales were already committed and priced, with some customers requesting commitments as far forward as 2Q 2022, and for the moment it expected upward pricing momentum to be continued. New sulphur capacity will probably make itself felt in 2022, but for the time being, it looks like we have not yet reached the peak of this particular sulphur rally. ■

Richard Hands, Editor

We are everything sulphur and much more

Comprimo and Chemetics – delivering sulphur and sulphuric acid solutions for a more sustainable world.

Through everything we do, we provide maximum long-term profits for our customers while meeting the most stringent environmental requirements. Helping our customers to be better neighbours is always good business for them and us.



Decrease OPEX



Reduce emissions



Energy efficiency

Learn more with one of our experts
email: sulphursolutions@worley.com

“Phosphate prices like that can support high sulphur prices, but for how long?”

Comprimo®

worley.com/comprimo

CHEMETICS®

worley.com/chemetics

SULPHUR
ISSUE 397
NOVEMBER-DECEMBER 2021

BCInsight

Southbank House, Black Prince Road
London SE1 7SJ, England
Tel: +44 (0)20 7793 2567
Fax: +44 (0)20 7793 2577
Web: www.bcinsight.com
www.bcinsightsearch.com

CONTENTS

What's in issue 397

COVER FEATURE 1

Sour gas projects

COVER FEATURE 2

Demand for sulphur fertilizers

COVER FEATURE 3

Options for sour water stripper gas

COVER FEATURE 4

Sulphuric acid projects and technology



MARKET INSIGHT

Meena Chauhan, Head of Sulphur and Sulphuric Acid Research, Argus Media, assesses price trends and the market outlook for sulphur.

SULPHUR

The more stable and slightly softer tone to the global sulphur market has given way to firmness. There has been considerable uncertainty in the market in recent months, with new capacity yet to come online in the Middle East and restrictions on Chinese processed phosphates exports lacking clarity. DAP prices have rallied through October meanwhile, providing strong support to sulphur markets and pricing. The Middle East sulphur benchmark breached the \$200/t f.o.b. mark in October and was assessed by Argus at \$223-230/t f.o.b. on 28th October, with the expectation of further firming in the short term.

Restrictions on Chinese exports had been expected, with discussions taking place in recent months. Exports of phosphates, largely DAP and MAP, will be restricted as producers have made agreements with China's top economic planning agency the NDRC to curb exports. Some Chinese port authorities halted fresh deliveries and since 15th October fertilizer export inspections also commenced. The restrictions are expected to remain in place until June 2022. This has led to supply concerns in the DAP market and the short term market balance moving to deficit or tighter in the forecast.

Port inventories in China continued to fall in October before steadying at around 1.5-1.6 million tonnes. The likelihood of stocks being replenished was limited until import prices see a correction. Domestic prices

in the country softened through October. The government is enforcing restrictions on energy consumption and energy intensity across a range of industries in a drive to curb emissions. The move comes on the back of China's pledge to achieve carbon neutrality by 2060 and puts in question the expected increase in oil-based sulphur production in the second half of 2021. In the longer term, increased integration and forecast expansions in the Chinese refining sector means China's reliance on sulphur imports is expected to decline. But the clamp down on energy use and focus on emissions reductions may impact the rise of new capacity and production.

Middle East producers increased official selling prices into the low \$190s/t f.o.b. at the start of October, up by around \$11-14/t on September. The increases at the time reflected strong buying activity from China and India with product availability deemed to be stable. Strong demand has been driving the tightness and led to spot prices firming beyond posted prices at the start of the month. 4Q contracts for Middle East supply concluded at \$180/t f.o.b., with higher volume buyers in north Africa securing slightly lower settlements at \$175-180/t f.o.b.

Opec+ continues to ease its crude production restraints in line with its previously agreed plan. The group confirmed at the start of October that it will stick to the planned increase of 400,000 bbl/d in November. Meanwhile, crude prices have continued to rise, despite the increase

in output because of strong oil product demand. Increased travel on the back of continued Covid-19 restrictions being relaxed has contributed to this uptick.

Long delayed new sulphur capacity in the Middle East has yet to emerge but appears to be more promising for 2022. Kuwait's new 615,000 bbl/d Al Zour refinery entered into the commissioning stage. The first of three trains is expected to begin operations in February with the remaining two operational during the second half of 2022. Sulphur capacity at the refinery is 600,000 t/a. Meanwhile the Clean Fuels Project was reported as being operational.

Over in Brazil, sulphur prices were assessed at \$245-246/t c.fr at the end of October, firming by over \$100/t since the start of 2021. The phosphate market is heavily reliant on imports and supply concerns emerged following the news of Chinese export restrictions. Sulphur demand from domestic phosphate producers is expected to be strong to meet production rates.

In India, sulphur prices have also been rising as demand from phosphate producers remains strong while the country struggles with high DAP import process. Further support to the sulphur market is expected as the government is encouraging replenishment of sulphur stocks to supply increased domestic fertilizer production in the aftermath of the Chinese export clampdown. Higher prices in India continue to support the outlook for Middle East netbacks. Indian prices were assessed at \$277/t c.fr on average at the end of October. Delhi has approved a new fertilizer subsidy boost, offering temporary comfort to some trading companies. DAP import prices have rallied to levels far above the breakeven point of the DAP subsidy set back in mid-May. But

with DAP prices expected to continue to climb in the weeks ahead, it is unlikely to provide relief for long. Domestic producers will continue to achieve the most favourable DAP margins, which will continue to support sulphur demand.

SULPHURIC ACID

The firm trend in the global sulphuric acid market has not abated. Prices have continued to firm through to the end of October, with no signs of slowing. Tight supply coupled with strong demand has kept the market supported. Northwest European export prices were assessed at \$200-220/t f.o.b. at the end of October, slightly below highs of \$230/t f.o.b. earlier in the month. The European market was deemed to be in a critical state, as key suppliers curtailed production. Nyrstar announced it would be curtailing supply at three of its plants by up to 50% added concerns over security of supply for buyers in other regions. Prayon declared *force majeure* at its sulphur burner in Belgium in October. Strong import demand following the closure of Inovyn's sulphuric acid plant at Runcom is further exacerbating the market situation. The expectation is for further price increases before the end of the year. The tight balance is also pointing to a likely firm view for the early months in 2022. The shift in DAP and sulphur price direction in light of the new restrictions on Chinese DAP exports is also supporting the acid price outlook.

Chile spot prices have been a key market discussion, particularly as we approach negotiations for 2022 annual contracts. Prices firmed at the end of October to \$250-

260/t c.fr with traders pointing to higher freight rates. Spot business is expected to be slower with the focus turning to those price discussions but demand from the copper sector remains robust. There were indications from one buyer that a cargo had been secured for Q1 2022 at close to \$250/t c.fr. Planned maintenance at Anglo American's Collahuasi mine impacted copper production in Q3 2021, according to the company's production results. Copper production was down 6pm on the quarter, but up 1% year to date. The Tia Maria project in Peru appears to be facing further obstacles despite having necessary permits. The social and political environment has put the potential start up of the project in question following years of delays and opposition. If the project were to progress, it would lead to a significant increase in domestic consumption of acid produced from local smelters. This would impact export availability to main market Chile.

Over in Brazil, prices were stable in the second half of October after firming to \$255-260/t c.fr. November appeared to be covered at the time of writing but there was potential for a cargo for December. Itafos announced on 20 October that it had made the decision to restart its sulphuric acid plant at Arraias. The recommissioning of the plant is expected to be completed over a 4 month timeframe in order to commence sulphuric acid sale in the first quarter of 2022. Acid demand in Brazil has been high, with supply extremely tight through parts of the year. This has led to domestic prices in the market firming. The Itafos plant has

the capacity to produce 220,000 t/a acid. The plant had been idled since the fourth quarter of 2019, alongside the associated integrated phosphate fertilizer business. The associated plants will remain idled.

In Japan, planned smelter turnarounds during 4Q are expected to lead to lower sulphuric acid production compared with a year earlier. In South Korea, Namhae Chemicals was undergoing a month of planned maintenance at both of its 800,000 t/a plants until November. Prices out of South Korea/Japan have been much lower than the NW European benchmark. At the end of October, the northeast Asian high end of the price was \$70/t below the European export price. Expectations are stable in the outlook for export availability and capacity, with no closures or expansions currently planned in the forecast.

Sulphuric acid production in Namibia will be impacted by a water leak in the off-gas system at Dundee Precious Metals' Tsumeb smelter. The company has revised its production guidance down for 2021, with potential additional maintenance required at the plant. Tsumeb produced 249,000 t of acid in 2020. Supply from the smelter is primarily for the local market, with the balance exported to neighbouring countries in the region.

In the US, negotiations are underway for 2022 contracts. Prices were at \$245-255/t c.fr at the end of October for spot volumes. The market is expected to remain tight through 1H 2022 with strong demand from various sectors. Imports are expected to increase next year.

Price Indications

Table 1: Recent sulphur prices, major markets

Cash equivalent	May	June	July	August	September
Sulphur, bulk (\$/t)					
Adnoc monthly contract	189	184	175	175	180
China c.fr spot	233	249	256	215	230
Liquid sulphur (\$/t)					
Tampa f.o.b. contract	192	192	195	195	195
NW Europe c.fr	228	228	228	228	228
Sulphuric acid (\$/t)					
US Gulf spot	160	160	190	230	230

Source: various

Fig. 1: Global sulphuric acid demand changes (y-on-y growth)

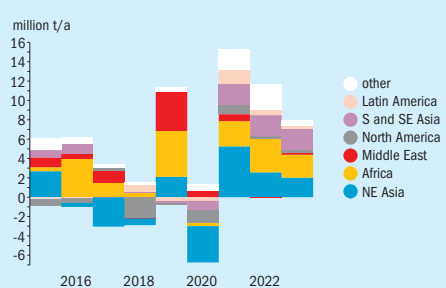

Source: Argus Sulphuric Acid Analytics

Fig. 2: Monthly Middle East sulphur producer prices

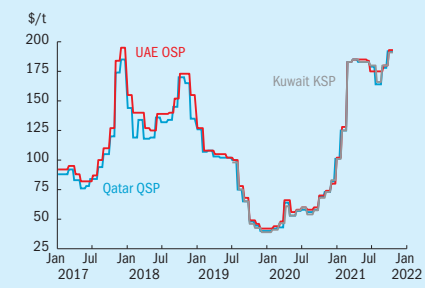

Source: Argus Sulphur

CONTENTS

What's in issue 397

COVER FEATURE 1

Sour gas projects

COVER FEATURE 2

Demand for sulphur fertilizers

COVER FEATURE 3

Options for sour water stripper gas

COVER FEATURE 4

Sulphuric acid projects and technology

Market Outlook

Historical price trends \$/tonne

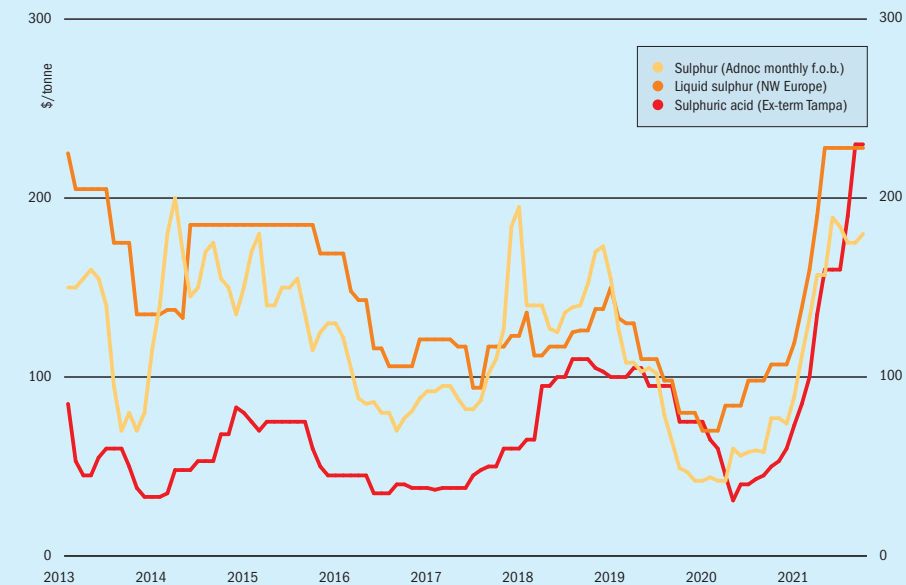

Source: BCInsight

SULPHUR

- A seasonal decline in weather conditions in the eastern Atlantic will hinder operations at Jorf Lasfar in Morocco through the end of 2021 and into 2022. In South Africa, port congestion problems were challenging at Richard's Bay with vessels subjected to 15 day wait times, increasing demurrage costs.
- Indian state refiners increased refinery run rates in October following an anticipated increase in fuel demand. IOC is expected to increase run rates to 90% in October from 85% in September, before upping rates to 95% in November. Indian sulphur capacity is forecast to rise by over 100,000 t/a by 2023, raising domestic output.
- Outlook: Global sulphur prices are likely to firm further, driven by demand side fundamentals and supported by the short term rally in the DAP market. The outlook for new supply in the 2022-2023 period is healthy, based on projects in the pipeline, the key

assumption behind the potential downside to the market view. Strength from non-fertilizer sector demand such as nickel is expected to provide considerable growth in trade volumes to markets including southeast Asia.

SULPHURIC ACID

- Maintenance turnarounds – both planned and unplanned – have supported the tight balance over the course of the year so far and will continue to squeeze availability in the spot market into 2022. Rio Tinto's Kennecott smelter in Utah was still offline at the end of October following an accident while Vale production at Sudbury was down by 27% for nickel and 6% for copper due to the strike there.
- Nationwide power rationing in China and slowing demand for sulphuric acid is understood to have led to copper smelter Tongling Nonferrous Metals reducing its output. Its Jinlong and Jinguan smelters started to cut operating rates by around 20% from 22 October 2021 with high sulphuric acid stocks

also being a factor. Power curbs in China hit chemical and steel sectors and affected operations at several copper smelters, temporarily disrupting acid output.

- In the wider economy, inflation in the eurozone grew to 4.1% in October, jumping from 3.4% in September, a flash estimate from Eurostat shows. Inflation is at its highest since July 2008, driven by significantly higher energy prices and supply-chain price pressures.
- Outlook: Sulphuric acid is expected to remain at a premium to sulphur through the fourth quarter and into 2022. The tight smelter-acid sector is supporting the view for firmer in the coming months. The potential for a price correction remains, potentially in 2022, particularly if DAP and sulphur prices both see substantial decreases. However, with demand expected to remain robust across most sectors including metals, the disconnect with sulphur may prevent acid prices from following the same trends.

SAFEHR

HEAT RECOVERY TECHNOLOGY

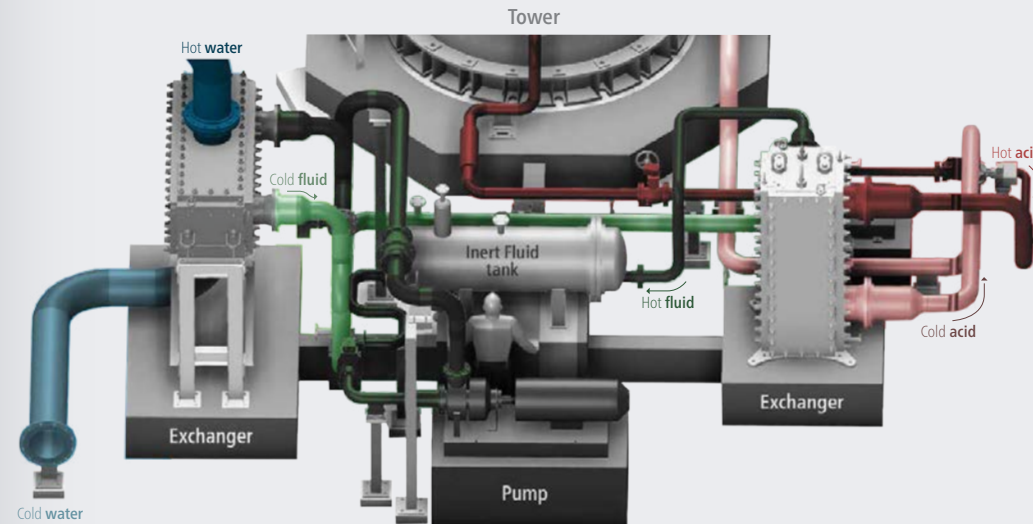

Failure safe

Waste energy recovery

Cooling water demand reduction

Recover more energy

Clark Solutions SAFEHR® is a patented sulfuric acid heat recovery technology which can increase high pressure steam generation in an acid plant by almost 20% and total energy recovery by as much as 35%, while addressing issues such as safety and corrosion in an absolutely innovative way.

Learn more: clarksolutions.com

CHINA

Start-up imminent for Shenghong refinery

China's private sector Shenghong Petrochemical refining complex is targeting a start-up in late November, following the receipt of its first cargo of crude in October. The greenfield refining complex in the eastern Lianyungang petrochemical zone has a capacity of 16 million t/a, including a 320,000 bbl/d crude unit – the largest single stream CDU in China – and a 76,000 bbl/d naphtha reformer. Product capacities include 56,000 bbl/d of gasoline, 41,000 bbl/d of diesel and 32,000 bbl/d of jet fuel. Construction began in mid-2019, delayed from 2018 by late approval of its environmental impact assessment, but has been achieved within two months of the scheduled completion date in spite of the coronavirus pandemic. Shenghong Petrochemical is owned by Eastern Shenghong, a producer of petrochemical products and chemical fibres.

Like other major new greenfield refineries Rongsheng ZPC and Hengli Changxing, Shenghong is designed to use sour crude from the Arabian Gulf. The refinery's sulphur recovery section has a capacity of 600,000 t/a.

POLAND

Tecnimont to build new hydrocracker

Maire Tecnimont says that its subsidiary KT – Kinetics Technology has been awarded a €200 million lump sum turnkey engineering, procurement and construction contract by LOTOS Oil, to build a new hydrocracking unit with associated logistic facilities for the LOTOS Gdansk refinery. Project completion with fully operational facilities is expected by the first half of 2025. This plant will be capable of treating better performing base oil groups, with a lower environmental impact. International environmental regulations are driving the need for higher quality base oils, especially in the automotive sector, where engine oil manufacturers are responding to increasing demand for low sulphur and energy-efficient products.

Pierroberto Folgiero, Maire Tecnimont Group CEO, commented: "We are delighted to continue our long-lasting, mutually beneficial cooperation with such a prestigious client, thanks to this third EPC project awarded to our Group and concerning the Gdansk Refinery. With this award we further strengthen our footprint in Poland as well as our strong commitment to support the LOTOS Group in ensuring the best environmentally performing processes and products".

PAKISTAN

Axens to modernise Byco refinery

Axens has been selected to support Byco's refinery upgrade project in order to meet Euro V gasoline and diesel speci-

fications in Pakistan. The scope of Axens' work includes the supply of a process design package for integration of three existing units into a FCC gasoline hydro-treating configuration using licensed Prime-G+® technology, as well as catalysts and adsorbents for the sulphur recovery unit and hydrotreaters, internals for the distillate hydrotreater, training and long term technical services. The upgrade is scheduled to be completed by Q2 2024. The award follows cooperation between the two companies that began in 2019 when Byco awarded Axens a study to evaluate the configuration of units for the modernisation. Byco operates Pakistan's largest refinery, a 156,000 bbl/d facility at Mouza Kund, 20km west of Karachi.

COLOMBIA

Ecopetrol looking to green and blue hydrogen

Colombia's state-owned Ecopetrol says that it is looking at a variety of green hydrogen pilot projects, including for its Cartagena and Barrancabermeja refineries, with a total investment cost of \$200-300 million. The first step on the company's hydrogen roadmap will be to import an electrolysis unit from Spain in 1Q 2022 to test integration with existing hydrogen production at its 165,000 b/d Cartagena refinery, on the Caribbean coast. Ecopetrol's refineries consume 130,000 t/a of hydrogen as part of desulphurisation sections, most at Cartagena and around one third at its 250,000 bbl/d Barrancabermeja refinery. The company is also looking at producing up to 50,000 t/a 'blue'

hydrogen, using carbon capture and storage, by 2030.

SWEDEN

Sandvik extends collaboration with Tenaris

Tenaris and long-standing business partner Sandvik Materials Technology say that they are extending their nearly 20-year alliance with the signing of a new five-year agreement for the supply of tubular products with premium connections and specialty steel alloys for the oil and gas market. The renewed agreement combines Sandvik's expertise in material technology and the development of corrosion-resistant steel alloys with Tenaris's excellence in the manufacture of high-quality, high-performing piping and connections.

KUWAIT

SRU fire at Mina al-Ahmadi

On October 18th a fire broke out in the sulphur recovery unit of the Mina Al-Ahmadi oil refinery in Kuwait, operated by the Kuwait National Petroleum Company (KNPC). There were no deaths but some minor injuries and several were treated for smoke inhalation. The fire occurred in the atmospheric residue desulphurisation unit (RDU), but forced the shutdown of one of the refinery's two large 180,000 bbl/d crude distillation units. It was expected to take around three weeks to repair damage and restart production. The incident comes less than a month since full operations began at KNPC's Clean Fuels Project (CFP). The project involved the upgrade and integration of the firm's Mina al-Ahmadi and Mina Abdulah refineries, although the RDU was not part of the upgrade.

WORLD

HSFO market remains strong as ships switch to scrubbing

Platts reports that, contrary to initial expectations about the switch towards lower sulphur bunker fuels as part of the International Maritime Organisation's low sulphur mandate, the high sulphur fuel oil (HSFO) market has remained relatively strong due to the uptake of exhaust scrubbing systems. Very low sulphur fuel oil (VLSFO) does represent 60-65% of global bunker demand at present, but in Singapore, the world's largest bunkering port, HSFO demand has remained strong, with sales

of HSFO up 2.7% year on year, as larger ships, which tend to be the ones with scrubbing systems, use the port. Users of VLSFO pay on average a \$100/t premium over HSFO, which can make the cost of scrubbing systems attractive, especially for new build vessels.

UNITED STATES

Piñon sour gas facility nearing capacity

Piñon Midstream says that its greenfield sour gas treatment and carbon capture facility in New Mexico is near its initial capacity, and the company is installing its second facility. The 85 million cfd Dark Horse facility, in Lea County New Mexico, uses amines to strip carbon dioxide and hydrogen sulphide from natural gas and delivers sweet gas to third-party mid-stream operators. The sequestered acid gas is then reinjected into the well. A second, 170 million cfd treatment facility is expected to be completed before the end of the year. The company says that the first well has the capacity to permanently sequester up to 175,000 tonnes of CO₂ and 75,000 tonnes of H₂S per year. The company is also adding a second well that will be completed in 2022 which will double this.

"We are excited to announce that our Dark Horse Facility is open for business," said Piñon Midstream co-founder and president Steven Green. "The producers in our area have had a dire need for a long-term



Piñon Midstream's Dark Horse facility under construction.

Sulphur 397 | November-December 2021

and environmentally friendly solution to the extreme acid gas concentrations that have previously challenged the region. By removing and sequestering these gases, the Dark Horse Facility makes it possible for operators to realise a single-source solution to CO₂ and H₂S contaminants that are prevalent throughout the basin."

Flame retardant sulphur plastics

University of Arizona researchers say that they have developed a way to turn sulphur into a flame retardant, high-end plastic. The work comes at the end of 10 years of research by the team to find uses for elemental sulphur. Two years ago, Jeff Pyun, a professor in the Department of Chemistry and Biochemistry and his colleagues, created lenses made of sulphur for infrared detectors. Now, they have created a high-end thermoplastic elastomer out of sulphur. The material is rubbery, elastic and mouldable compared to stiffer plastics. Other types of thermoplastics are used to make the grips on items such as power tools, pens and toothbrushes. The sulphur plastic created by Pyun and his team is flame retardant; soon as it catches fire, it immediately self-extinguishes instead of burning and creating heat and smoke. The researchers' work was funded by Eni, which partnered with the University of Arizona to develop and translate the technology.

"We are still in the early developmental stages, but this is the first demonstration of a polymer with these properties," said Pyun. The team's work is detailed in *Ange wandte Chemie*, a journal of the German Chemical Society. "It really stands out.. because almost all plastics are flammable," Pyun said. "Most plastics today are very cheap and have excellent mechanical properties that can be tunable over a broad range of products from automobile engine parts to rubber tires, but they're flammable. Plastics that have really good properties and are flame retardant, such as this one, are very expensive. What we eventually want are plastics that are low-cost, with good properties, and are flame retardant."

UNITED ARAB EMIRATES

ADNOC looks to huge LNG export terminal

The Abu Dhabi National Oil Company (ADNOC) is reportedly planning a huge LNG export terminal at Fujairah on the Gulf

CONTENTS

What's in issue 397

COVER FEATURE 1

Sour gas projects

COVER FEATURE 2

Demand for sulphur fertilizers

COVER FEATURE 3

Options for sour water stripper gas

COVER FEATURE 4

Sulphuric acid projects and technology

SULPHUR
ISSUE 397
NOVEMBER-DECEMBER 2021

BCInsight

Southbank House, Black Prince Road
London SE1 7SJ, England

Tel: +44 (0)20 7793 2567

Fax: +44 (0)20 7793 2577

Web: www.bcinsight.com
www.bcinsightsearch.com

UNITED STATES

DuPont to license acid plant for Ioneer

A computer rendering of the new Rhyolite Ridge plant.



Lithium-boron miner Ioneer Ltd has awarded DuPont Clean Technologies a contract for the license, engineering, and supply of proprietary equipment for a planned sulphuric acid plant at the company's Rhyolite Ridge project in Nevada. DuPont will work with engineering partner SNC-Lavalin on the plant design, using MECS[®] sulphuric acid technology for the 3,500 t/d sulphur-burning unit, as well as controls that limit emissions to among the lowest in the world for this type of facility. DuPont will also supply its latest generation MECS[®] Super GEAR[™] catalyst and other critical proprietary equipment. The contract is conditional on a final investment decision by the Ioneer board of directors.

The acid will be used to leach lithium and boron from mined rock. The plant will also generate an initial 35 MW of electricity, sufficient to power the entire Rhyolite Ridge operation using primarily co-generated, zero-carbon power. The heat generated will also be used for evaporation and crystallisation processes required to produce lithium carbonate and boric acid. An air quality permit was awarded in June 2021 for what is the first sulphuric acid plant permitted in Nevada.

Rhyolite Ridge is expected to produce 20,600 t/a of lithium carbonate, converting in year four to 22,000 t/a of battery-grade lithium hydroxide, and 174,400 t/a of boric acid. Pending final Department of the Interior (DOI) approval of the plan of operation, the project is expected to begin production in the second half of 2024.

Commenting on the contract, Ioneer Managing Director, Bernard Rowe, said: "development of the Rhyolite Ridge lithium-boron project is a critical strategic step to enable US production of lithium-ion batteries for electric vehicles (EV) and renewable energy storage. Ioneer's core commitment is to produce essential materials in an environmentally and socially responsible and sustainable manner through lowered emissions, reduced water usage and a minimal surface footprint. We are delighted to welcome MECS-DuPont to our team."

Metso Outotec to supply copper leaching plant for Florence

Metso Outotec has signed an agreement with Florence Copper Inc., a subsidiary of Taseko Mines, to supply copper solvent extraction and electrowinning technology for a plant to be built in Arizona. Metso Outotec delivery includes the modular VSF[®]X solvent extraction plant and the main process equipment for the electrowinning plant.

"We are very excited to have purchased the key SX/EW process equipment from Metso Outotec, a world leader in mineral processing and hydrometallurgical technologies. The VSF[®]X technology is ideally suited for our Florence copper project, which is set to become one of the most energy-efficient and low-carbon copper producers in the world. The modular nature of the equipment will reduce construction time and allow Florence to commence copper production quicker than with other technologies available," said Stuart McDonald, President and CEO of Taseko Mines.

Smelter shutdown leads to disruption in acid supply

Rio Tinto declared *force majeure* on shipments of copper cathode and sulphuric acid from its Kennecott mine in late September after the smelter was shut down on September 21st following a release of molten copper materials. According to the announcement, Rio Tinto is assessing the work needed to safely restart operations at the smelter and is working closely with customers to minimise any impacts. Phosphate producer Itafos said that supply of sulphuric acid supply to its Conda, Idaho phosphate plant was disrupted as a result. Conda sources approximately 40% of its acid requirements internally and approximately 60% from a combination of volumes received from Rio Tinto's Kennecott mine under a long-term supply agreement and volumes procured from other third party producers. Conda produces around 550,000 t/a of mono-ammonium phosphate, superphosphoric acid, merchant grade phosphoric acid and ammonium polyphosphate.

INDIA

Paradeep targeting 2Q 2022 for phosphoric acid expansion

Fertilizers manufacturer Paradeep Phosphates Ltd says that it is looking at 1Q 2022 for an expansion of its phosphoric acid production by 120,000 t/a, as well as the installation of a new evaporator to increase strong phosphoric acid production by 116,000 t/a. The increases are part of a 50% increase in the company's capacity for producing non-urea fertilizers including diammonium phosphate and NPK by 50% from 1.2 million ta to 1.8 million t/a at its site at Paradeep in Odisha state. The estimated investment on the expansion projects would be close to \$64 million. The funding will be partly through internal accruals and partly debt. Paradeep operates 1.3 million t/a of sulphuric acid capacity at the site.

CANADA

Metso Outotec to deliver SX plant for First Cobalt

Metso Outotec has signed an agreement with Canadian battery materials recycling company First Cobalt Corporation to deliver solvent extraction technology

for First Cobalt's refinery expansion in Ontario. Metso Outotec's scope of delivery includes the engineering and supply of a modular VSF[®]X solvent extraction plant. First Cobalt aims to produce 25,000 t/a of high-quality, battery-grade cobalt sulphate using a proprietary acid leaching process called Re-20x. Their refinery in Ontario is currently the only permitted producer of battery-grade cobalt for the North American electric vehicle market.

"We are happy to be moving forward with Metso Outotec, an industry-leading business partner. Metso Outotec was selected based on its competitive pricing and technically superior bid. The contracted solution involves the latest advancements in solvent extraction in terms of modular design, process control, and ease of installation and start up," said Trent Mell, president & CEO of First Cobalt.

nesian production. Indonesian exports of unprocessed nickel ore ceased in January 2020 due to a ban imposed by the government. As a consequence, China had less material available to feed its nickel pig iron (NPI) industry resulting in a decrease in Chinese NPI production. New NPI projects in Indonesia ramped up strongly in 2020 and it is anticipated that this trend will continue in 2021 and 2022. World nickel mine production declined in 2020, mainly due to the Indonesian ore ban, but recovered in 2021 and is expected to continue to increase in 2022. Indonesia is the world's top nickel miner due to its expanding domestic nickel industry. High pressure acid leaching projects being developed in Indonesia and other parts of the world will further increase global mine output.

NEW CALEDONIA

Tesla signs supply agreement with HPAL plant

Nickel producer Prony Resources New Caledonia has struck a deal with the car manufacturer Tesla to supply 42,000 t/a of the metal by 2024 for use in Tesla car batteries. Negotiations had been under

WORLD

Nickel output forecast to rise by 18% in 2022

The International Nickel Study Group says that it expects global demand for nickel is expected to increase to 3.04 million t/a in

EGYPT

Nuberg wins acid plant contract

Nuberg EPC has been awarded a contract to supply a 500 t/d sulphur burning acid plant and 5 MW power generation plant by the International Company for Chemical Industry (ICCI) at its site at Gamasa City, west of Damietta, Egypt. The project will use Nuberg's double contact double absorption process. Nuberg's scope of services includes process design and technology development including product and technology development, process know-how & licensing, basic engineering, front end engineering design (FEED), construction management, operation & maintenance, detailed engineering, project management, commissioning, EPC and lump sum turnkey solutions, heavy fabrication, and start-up of the plant, which is scheduled for 3Q 2023.

BRAZIL

Itafos restarting sulphuric acid plant at Arraias

Phosphate producer Itafos says that it will restart its sulphuric acid plant in Arraias in the state of Tocantins over the next four

STEULER Surface Protection | Linings

THE ACID PROOF BRICK
NOW AVAILABLE IN US-SIZES

Protection against extremes is what our bricks stand for more than 111 years – worldwide. No breakage on pallets to be calculated - just order the amount you need for a direct, safe and binding delivery! What other challenges can we solve for you? Please reach out to us and we will find the right lining system for any kind of specification.

Directly from our warehouse in Houston, Texas - Just call us - We deliver!

STEULER-KCH GmbH
Phone: (713) 405-3545 | theacidproofbrick@steuler.com www.theacidproofbrick.com

CONTENTS

What's in issue 397

COVER FEATURE 1

Sour gas projects

COVER FEATURE 2

Demand for sulphur fertilizers

COVER FEATURE 3

Options for sour water stripper gas

COVER FEATURE 4

Sulphuric acid projects and technology

SULPHUR
ISSUE 397
NOVEMBER-DECEMBER 2021

BCInsight

Southbank House, Black Prince Road
London SE1 7SJ, England
Tel: +44 (0)20 7793 2567
Fax: +44 (0)20 7793 2577
Web: www.bcinsight.com
www.bcinsightsearch.com

steam output. PVS will not only be able to supply steam generated from the new boilers to an industrial neighbour, but will also prevent approximately 11,700 tons of CO₂ from entering the atmosphere every year. The PVS sulphuric acid plant in Gent is one of the few sites globally to produce ultra-high purity sulphuric acid, a critical ingredient for the semiconductor chip industry.

David Nicholson, president and CEO of PVS Chemicals Inc. said, "This project and the teamwork, perseverance and hard work shown by all project members, including MECS® field services who worked alongside us through successes and difficulties to deliver the plant, ensure PVS Belgium has a bright future. This project builds on the 126 years of history at this plant and gives it a new heart, so it is ready to run for decades to come."

Eli Ben-Shoshan, Global Business Leader, DuPont Clean Technologies, said, "Sulphuric acid plants are key sources of carbon-free energy. By capturing that energy, the industry can contribute to decarbonising thermal energy production. We are delighted to be able to assist PVS Chemicals in that aim and to help the plant optimize energy recovery while ensuring reliable, high quality sulphuric acid production so the plant can consistently meet production capacity targets."

CHINA

Smelters return to production

Copper smelter Tongling Nonferrous Metals has reportedly reduced its output in response to national power rationing and lower demand for sulphuric acid. Its 350,000 t/a Jinlong and 200,000 t/a Jinguan smelters have cut operating rates to about 80% from the second half of October because of high sulphuric acid stocks and depressed demand. Tongling produced 4.4 million t/a of sulphuric acid in 2020, according to Argus.

However, the 100,000 t/a Guorun copper smelter in Shandong province and 300,000 t/a Nanguo smelter in Guangxi province have recently returned to production after extending shutdowns from July into September. Shandong Fangyuan Nonferrous Metals has also restarted its 300,000 t/a refined copper smelter after a long shutdown. The restart of a significant chunk of smelting capacity comes as copper smelters and miners prepare for negotiations on treatment and refining charges (TC/RCS) for 2022. Greater operational smelting capacity means higher demand for copper concentrate, which pushes TC/RCS lower.

INDONESIA

Production ramps back up at Grasberg

Freeport-McMoran has nearly doubled copper and gold production at its large Grasberg mine after a lull due to covid. The company says that it produced 448,000 tonnes of copper in the third quarter, up from 384,000 tonnes in the same quarter last year, with output at Grasberg rising to 159,000 tonnes from 100,000 tonnes year-on-year. Production is currently at 90% of the projected level, and is expected to reach maximum by the end of 2021. Milling rates achieved over 177,000 t/d of ore in September, with the company expecting milling rates to average 175,000 t/d in the fourth quarter. Freeport is installing additional milling facilities in 2023, which will increase daily milling rates to 240,000 metric tons of ore per day.

The company has also broken ground on a new \$3 billion copper smelter and precious metals refinery in East Java as part of a deal that saw Grasberg's mining license extended to 2041, with the Indonesian government taking a majority stake in the mine. Speaking at the ground breaking ceremony, Indonesia president Joko Widodo said that the construction of a domestic smelter would strengthen downstream industry in the Gresik Special Economic Zone and would attract other industries to invest. The new smelter will have a capacity of 1.7 million t/a. Chiyoda has been awarded the construction contract. In order to meet its commitment of reaching 2 million tonnes of concentrate smelting capacity by December 2023, the PT-FJ joint venture is also planning to fund a \$250 million, 30% expansion of its PT Smelting joint venture to take its capacity to 300,000 t/a.

ZIMBABWE

Zimplats plans smelter expansion

South Africa's Impala Platinum, which owns the Zimplats facility in Zimbabwe, has signed a memorandum of agreement with the Zimbabwean Ministry of Mines and Mining Development for a \$1.8 billion upgrade programme for Zimplats over the next seven years. The development plan will include an expansion of the Mupani and Hartley mines, as well as a new \$200 million base metal refinery to recover platinum group metals. A 110 MW solar power plant will also form part of the facility, and an expanded smelter which will take con-

centrate processing from 130,000 t/a to 380,000 t/a, with a sulphur dioxide recovery section and associated sulphuric acid plant. The sulphuric acid plant will have a projected capacity of 100,000 t/a, with the offtake likely to be used in the local production of phosphate fertilizers, replacing current acid imports.

Speaking at the signing ceremony, Zimbabwean president Emmerson Mnangagwa said that Zimplats intention to construct a base metal refinery is a crucial step towards local mineral beneficiation and value addition of the platinum group of metals.

"The sulphuric acid plant will contribute strategic raw materials needed in the local manufacturing of fertilisers and help reduce the importation of sulphuric acid. The adoption and use of smart energy sources by Zimplats through integrating the development of a 110 MW solar power plant is also commendable," he said.

ETHIOPIA

OCP signs agreement for phosphate fertilizer complex

The Ethiopian government signed a joint development agreement with OCP Group for the implementation of a fertilizer project in Dire Dawa in Ethiopia for a total investment of up to \$3.7 billion, according to the Ethiopian Ministry of Finance. The agreement was signed during a visit by a high-level delegation to Morocco, led by Ahmed Shide, Ethiopian Minister of Finance, accompanied by officials of the Ethiopian Chemical Industry Corporation, Ethiopian Agricultural Businesses Corporation, and the Ethiopian Mineral, Petroleum and Biofuel Corporation.

The fertilizer complex will require a \$2.4 billion in its first phase for the development of a 2.5 million t/a fertilizer unit including urea and NPK/NPS products, using phosphoric acid shipped in from Morocco, and could reach a capacity of 3.8 million t/a in the second phase.

New acid plant

In separate news, Indian plant constructor Nuberg EPC has been awarded a contract to revamp a 50 t/d sulphur burning sulphuric acid plant and 40 t/d aluminium sulphate plant for the Awash Melkassa Chemical Factory at Oromia. The work will be carried out on a lump sum turnkey basis and is due for completion by the start of 2023.

Sulphur 397 | November-December 2021

**ONLY
LEWIS®
HAS
LEWMET®**

Time and time again, it's proven that only strong Lewmet® alloys can handle long-term exposure to highly corrosive sulphuric acids. That's why non-Lewis® replacement parts just don't cut it. When working with sulphuric acid, you simply can't compromise – you need the best. Plus, we know exactly when they'll need replacing, which reduces unplanned downtime. Don't let imitation parts affect your plant's performance, always use genuine Lewis® parts.

Learn more at onlylewis.weir

Copyright © 2019, Weir Minerals Australia Limited. All rights reserved.

WEIR

LEWIS®

Minerals
www.minerals.weir

CONTENTS

What's in issue 397

COVER FEATURE 1

Sour gas projects

COVER FEATURE 2

Demand for sulphur fertilizers

COVER FEATURE 3

Options for sour water stripper gas

COVER FEATURE 4

Sulphuric acid projects and technology

SULPHUR
ISSUE 397
NOVEMBER-DECEMBER 2021

BCInsight

Southbank House, Black Prince Road
London SE1 7SJ, England

Tel: +44 (0)20 7793 2567

Fax: +44 (0)20 7793 2577

Web: www.bcinsight.com
www.bcinsightsearch.com

People

Anglo American plc has announced a number of senior leadership changes. **Seamus French** has decided to leave Anglo American at the end of 2021 after 14 years with the company and will be replaced as CEO of Bulk Commodities by **Themba Mkhwanazi**, currently CEO of Kumba Iron Ore. **Mpumi Zikalala**, currently managing director of De Beers Managed Operations, has been appointed as CEO of Kumba. Both appointments will take effect on 1st January 2022. Mpumi's successor at De Beers Managed Operations will be confirmed in due course.

Mark Cutifani, chief executive of Anglo American, said: "We congratulate Themba Mkhwanazi and Mpumi Zikalala on their new roles. Themba will shape the strategy for our global iron ore, metallurgical coal and manganese interests. The premium quality of our steelmaking ingredients and the partnerships we will continue to build to develop cleaner steelmaking technologies have never been more critical as we work to tackle climate change. Mpumi's extensive operational experience at De Beers will be instrumental as she builds on Kumba's progress to drive sustained safe, world-class performance working closely with its strategic business partners."

"I am also delighted that, together with Noliitha Fakude as chair of our management board in South Africa, and Natascha Viljoen as CEO of our PGMs business, we will have three women of such high calibre leading our extensive interests in South Africa."

"We thank Seamus for his enormous contribution and unfailing commitment to Anglo American over 14 years, both as CEO of our coal businesses and in his



Ruben Fernandes, Anglo-American.

more recent role leading our global bulks operations and strategy. His work to draw out considerable operational synergies and sharing of best-practice has enhanced our capabilities and been central to our performance improvements over many years. We wish him well."

In conjunction with these changes, **Ruben Fernandes**, CEO of Base Metals, will also take on accountability for the iron ore and the nickel operations in Brazil. As planned, the Quellaveco copper operation in Peru will also move to the Base Metals portfolio once it is commissioned. This streamlining of responsibilities will allow Ruben to maximise efficiencies across all of Anglo American's operations in South America, alongside his global strategic responsibilities for base metals.

Nevada Copper Corp. has named **Randy Buffington** as its next president and chief executive officer. He succeeds

Mike Brown, who served in the roles on an interim basis. Brown has been a non-executive director of the company since 2013 and he will continue to be actively involved as a director, the copper producer said. Buffington previously served as the president and CEO of gold and silver producer Hycroft Mining Holding Corp. He has experience with multiple project ramp-ups and with improving the productivity in underground and open pit mining operations, the company said. Nevada Copper's previous president and CEO, **Mike Circillo**, stepped down from his post in August.

Chile's Minera Escondida, the world's largest copper mine, has appointed **Edgar Basto** as its new CEO, effective from December 1st. Escondida is 57% owned by BHP, in which Basto has served since 1989. He was appointed president of Minerals Australia on 1st July 2020 and was responsible for BHP's iron ore and nickel operations in Western Australia, metallurgical and energy coal in Queensland and New South Wales, and copper in South Australia. He has extensive experience in the resources industry, with a long career spanning multiple commodities in Australia, Colombia, Chile and Peru. He has held numerous key leadership roles since joining BHP in 1989, including vice president Global Health, Safety, Environment and Communities (HSEC), Asset President Escondida and Asset President Western Australia Iron Ore. He holds a Bachelor of Science (Metallurgy) from the Industrial University of Santander and has recently received an Honorary Doctorate in Engineering from Edith Cowan University. ■

Sour gas projects



PHOTO: CONOCOPHILLIPS

Although the number of new sour gas developments has slowed in recent years compared to the large boost of the previous decade, sour gas projects continue to be a major source of new sulphur production.

Left: LNG tankers being loaded at Ras Laffan, Qatar.

Sulphur extraction from processing of sour gas represents around 50% of all recovered sulphur, and can have an outside effect on sulphur markets. While sulphur recovery projects at refineries are often incremental, sour gas plants often process large volumes of gas and hence recover large tonnages of sulphur, making the project slate for new sour gas developments all the more important. Globally, around one third of all sour gas reserves can be classified as highly sour (>1% H₂S), and these are concentrated in four main regions: the Middle East, Central Asia, China, and North America. Each has had a history of sour gas development, for different reasons, but the Middle East has the largest proportion of sour reserves, sometimes up to 20-30% H₂S, and the largest incentive to develop them.

20th century, with the exception of Qatar, whose lack of oil led it to instead focus on developing its gas reserves. However, rising populations and developing cities have left many states needing additional gas for refineries and are now leading to the tapping of these sour gas reserves.

Abu Dhabi

New gas discoveries in Abu Dhabi have recently brought reserves in the UAE to the sixth largest in the world, though gas production in the Emirates has plateaued at just below 60 bcm per year, and runs behind consumption of around 70 bcm. The UAE as a whole has been a net importer of gas since 2008 as the fast growing cities of Dubai and Abu Dhabi require more power. Gas is imported from Qatar along the Dolphin pipeline, and to Dubai as LNG, though ADNOC also exports 7.7 bcm of LNG from the offshore Das Island terminal.

Abu Dhabi has hugely ambitious plans for its oil and gas development. Last year its Supreme Petroleum Council approved a \$122 billion investment plan for oil and gas out to 2025, including raising oil capacity by 1 million bbl/d to 5 million bbl/d (even though the UAE's OPEC quota is currently

only 2.4 million bbl/d). The Council is also looking to try and achieve self-sufficiency for the UAE in gas production, and possibly even become a net exporter.

To do so Abu Dhabi's National Oil Company (ADNOC) has been forced to exploit large sour gas fields both onshore and offshore of the Emirate. Currently the largest gas processing sites are at Habshan, which processes gas from the Bab, Umm Shaif and Thamma fields, and the large onshore Shah gas field and processing plant, in the desert 210 km southwest of Abu Dhabi. Both sites produce around 10,000 t/d of sulphur, for a total of 6.6 million t/a. Another 400,000 t/a comes from the Das Island plant, with the Ruwais refinery generating another 100,000 t/a.

However, there are major sour gas expansions in the pipeline. Germany's Wintershall and Italy's ENI are working with ADNOC to develop the Hail and Ghassha offshore ultra-sour gas fields. This will involve the construction of artificial islands and two causeways. It is expected to produce over 1.5 billion scf/d of sales gas by around 2025. In addition, ADNOC plans to boost production from its Shah sour gas field from about 1.3 billion scf/d to 1.5 billion scf/d through its joint venture with Occidental. It also plans to move forward

Middle East

Sour gas in the Middle East centres around the huge Khuff basin, which extends under the waters of the Arabian Gulf offshore of Saudi Arabia, Iran, Qatar and Abu Dhabi, and then onshore through the east of Saudi Arabia, south of the UAE and into Oman in the east. Most of the countries concentrated on oil production during the

! The following events may be subject to postponement or cancellation due to the global coronavirus pandemic. Please check the status of individual events with organisers.

Calendar 2021/2022

NOVEMBER 2021

15-18

European Refining Technology Conference, MADRID, Spain
Contact: Sandil Sanmugam, Portfolio Director, Europe, WRA Conferences
Tel: +44 20 7384 7744
Email: sandil.sanmugam@wraconferences.com
Web: worldrefiningassociation.com

22-26

Advanced Amine Treating and Sulphur Recovery Seminar, NOORDWIJK, Netherlands

Contact: Paula Zaharko, Sulphur Experts
Tel: +1 281-336-0848 Ext 101
Email: Paula.Zaharko@SulphurExperts.com

JANUARY 2022

23-25

Sour Oil and Gas Advanced Technology (SOGAT), ABU DHABI, UAE
Contact: Nick Coles, Director - Conferences, DOME Exhibitions, PO Box 52641, Abu Dhabi, UAE
Tel: +971 2 674 4040
Email: nick@domeexhibitions.com

FEBRUARY

1-4

SulGas Conference 2022 - Virtual event
Contact: Conference Communications Office
Tel: +91 73308 75310
Email: admin@sulgasconference.com

21-24

Laurance Reid Annual Gas Conditioning Conference, NORMAN, Oklahoma, USA
Contact: Lily Martinez, Program Director
Tel: +1 405 325 4414
Email: lmartinez@ou.edu

MARCH

7-9

CRU Phosphates 2022 Conference, TAMPA, Florida, USA
Contact: CRU Events
Tel: +44 (0) 20 7903 2444
Email: conferences@crugroup.com

CONTENTS

What's in issue 397

COVER FEATURE 1

Sour gas projects

COVER FEATURE 2

Demand for sulphur fertilizers

COVER FEATURE 3

Options for sour water stripper gas

COVER FEATURE 4

Sulphuric acid projects and technology

SULPHUR
ISSUE 397
NOVEMBER-DECEMBER 2021

BCInsight

Southbank House, Black Prince Road
London SE1 7SJ, England
Tel: +44 (0)20 7793 2567
Fax: +44 (0)20 7793 2577
Web: www.bcinsight.com
www.bcinsightsearch.com

to develop sour gas fields at Bab and Buhasa.

The Shah expansion is expected to increase sulphur production by 5,000 t/d (1.6 million t/a) from about 2024. Ghasha/Hail is at an earlier stage – contracts are still being awarded and the front end engineering design is being rejigged, and the project may not reach capacity until towards the end of the decade.

Qatar

Qatar's sour gas production comes from processing gas from the North Field, the largest natural gas field in the world. Gas from the North Field is typically around 0.5% H₂S, but can range as high as 6%. What has driven Qatar's sulphur output is the decision to become the world's largest LNG exporter, and the sheer volume of gas which that requires to be processed. Via seven majority owned operating company joint ventures with Exxon, Conoco, Shell and others, at the start of 2020 state gas monopoly Qatargas operated 14 LNG trains with a total capacity of 68 million t/a of LNG. Gas is brought ashore and processed at Ras Laffan at the tip of the peninsula, and sulphur sent to the Common Sulphur Facility at the site for export.

Most of this LNG capacity was built during the 1990s and 2000s, and Qatar maintained a moratorium on new gas-based developments from 2011-17 to extend the life of its reserves. However, it did proceed with one project during this time, albeit delayed on several occasions; the Barzan LNG project, in which ExxonMobil is a 7% shareholder. There are two LNG trains in the Barzan project, with a combined capacity of 1.4 billion scf/d (9.8 million t/a). Although construction was largely completed by 2014, the start-up date for Barzan slipped from its projected 2015-16 first because of leaks in the gas pipeline running from the production wells to the mainland, and then because of the covid pandemic. However, ExxonMobil says that the project did finally start operations during 2020.

Additional sulphur from Barzan gas has added several thousand t/a to Qatar's production. In September 2021 Qatargas announced that it had achieved the milestone of a stable 10,000 t/d of sulphur output.

phur output at Ras Laffan during August; equivalent to 3.3 million t/a (the figure includes sulphur from refinery processing at Ras Laffan, but is mostly from sour gas operations).

Qatar has now decided to raise output by a further 32 million t/a of LNG via the North Field Expansion Phase 1. This project too has slipped however, and choice of project partner will now not be until the start of 2022. A final investment decision on the 16 million t/a second phase should also come in the first quarter of 2022, according to Qatargas. Phase 1 could begin operations in 2025, and would add another 600,000 t/a of sulphur production capacity.

Saudi Arabia

Saudi Arabia has the fourth largest gas reserves in the world, but for many years focused rather upon its oil output and let much gas go to flaring. Beginning in the 1980s it began construction of its Master Gas Gathering System for associated gas, and began to consume gas domestically for power generation, water desalination, enhanced oil recovery, and other industrial consumption (eg ammonia, methanol production). However, Saudi Arabia's gas demand continues to rise. One driver is an attempt to reduce consumption by oil-burning power stations to free up more oil for export. However, much of the country's domestic gas production is from associated gas, and hence production can be constrained by OPEC quotas. To overcome this Saudi Arabia has turned to its standalone gas reserves,

most of which are sour, and therefore, like Abu Dhabi, Saudi Arabia has found itself increasingly having to process highly sour gas fields. The Kursaniyah gas plant started up in 2012, followed by Wasit in 2016, with a gas processing capacity of 2.5 billion scf/d and sulphur production of 1,200 t/d. The Fadhilli gas plant began operations in 2020. At capacity it processes 2 billion scf/d of gas from the offshore Hasbah field to generate sales gas and 500 million scf/d from the onshore Khursaniyah field to operate a cogeneration power plant. Sulphur output from Fadhilli is 4,000 t/d (1.3 million t/a) at capacity, taking Saudi sulphur production

capacity to 8.5 million t/a, nearly 90% of that from gas processing.

Upcoming expansion projects are focused mainly upon oil but will produce some associated gas and condensates. The Marjan expansion project aims to increase the oil production by 300,000 bbl/d, with a similar amount of condensates, as well as large volumes of associated gas. As part of the expansion, increased associated gas from the Zuluf field will be separated and sent to the onshore Tanajib gas plant, which is being expanded to handle an additional 2.5 billion scf/d of gas. Aramco says that it expects Tanajib to become operational in 2025.

In the longer term, Aramco has also announced the development of the huge Jafurah gas field, the largest unconventional non-associated gas field in the Kingdom, covering 170 km by 100 km and containing 200 tcf of gas. Production is expected to begin in 2024, but will not reach its target of 2.2 billion scf/d of sales gas until 2036.

Central Asia

The area of sour gas exploitation in Central Asia is mostly around the Caspian Sea region, in Russia to its west, Kazakhstan to its north and east, and the zone of sour oil and gas reserves extends further south east into Turkmenistan and Uzbekistan. Onshore deposits in Russia and Kazakhstan are the longest standing and most mature, with discoveries going back to the 1960s and exploitation to the 1980s, while new exploration has focused on offshore reserves in the North Caspian and onshore reserves into Turkmenistan.

Russia produced 5.0 million t/a of sulphur from sour gas processing in 2020, according to Gazprom, down from 5.4 million t/a in 2019. Some of this sulphur comes from gas piped across the border in Kazakhstan, from the Karachaganak field. While there are no new sour gas projects in Russia, Karachaganak is involved in a debottlenecking project which aims to process sour gas on the Kazakhs side of the border to expand production. However, the acid gas separated from the sales gas will be reinjected into the well.

Elsewhere in Kazakhstan, the largest producer is TengizChevroil (TCO), which is a joint venture between Chevron (50%), ExxonMobil 25%, KazMunaiGaz 20%, and Russia's Lukoil 5%. TCO produces around 2.5 million t/a of sulphur, and although

there is a wellhead pressure maintenance project planned to be completed in 2023, this will also involve acid gas reinjection to boost oil output, and no extra sulphur will be produced.

Kashagan in Kazakhstan is another oil project with sour associated gas. Oil production was supposed to be 450,000 bbl/d in the first phase, but is likely to run at only 300,000 bbl/d this year. One barrier to increasing capacity is reportedly throughput of the associated gas processing section, and so there is now a new plan in train to build a new gas processing plant 12 km northeast of the existing onshore Bolashak oil and gas treatment complex, to accommodate associated gas production from Kashagan. The \$860-million gas plant will have a design capacity to process 1 bcm of sour gas from Kashagan to produce 0.82 bcm of sales gas, and 155,000 t/a of liquid fractions and condensate. It will also increase sulphur production by 210,000 t/a. Commissioning is currently set for 4Q 2023.

In neighbouring Turkmenistan, sulphur comes from the gas processing plant at Galkynysh (formerly known as South Yolotan), where gas with an H₂S content of around 6% is processed. Galkynysh is currently processing around 2 bcm of sour gas per month, according to Türkmengaz, and producing about 90,000 tonnes per month (1.1 million t/a) of sulphur.

Finally, the Kandym sour gas plant in Uzbekistan, which began operations in April 2018. It processes 8 bcm per year of sour gas and condensate from six gas fields; Kandym, Kuvachi-Alat, Akkum, Parsanal, Khoji and West Khoji. Sulphur production is running about 180,000 t/a.

China

China's demand for gas is growing faster than any other country in the world, as its government tries to pivot away from its reliance on coal in a bid to reduce pollution and smog as well as lower the country's carbon emissions. This is leaving the country with a growing deficit however. Petrochina says that it estimates Chinese gas demand for 2021 will be 350-356 bcm per year, up almost 10% on 2020's figure of 326 bcm. Chinese gas production reached 193 bcm in 2020, up by 9.8%, but imports continue to grow. To meet its rapidly growing demand China is looking to any potential sources of gas, including shale gas, coalbed methane and sour gas.

China's sour gas fields are mostly in the southern province of Sichuan, where there are three major projects with associated gas processing capacity. The Puguang sour gas processing plant, operated by Sinopec, became operational in 2011, and produces around 1.7 million t/a of sulphur. Sinopec's other field, Yuanba, began operating in 2014. Sulphur content of the gas is lower here and total sulphur output is around 300,000 t/a.

The last of the three is a partnership between the China National Petroleum Corp and Chevron at Chuandongbei. Gas production began in 2016, and there is a 400,000 t/a sulphur plant as part of the development. Chuandongbei is the only one of the three sour gas plants where there are expansions likely in the near future. The second stage of development, scheduled for 2023, will include the Tieshanpo gas field and the construction of another gas processing plant. A final stage will involve the development of the Dukouhe and Qilibei gas fields. Sulphur output is likely to increase by 300,000 t/a with the completion of Phase 2.

North America

Sour gas production in North America comes mainly from the Rocky Mountains, in a belt extending from British Columbia in the north, through Alberta and then down into the continental United States. This region was the birthplace of the sour gas and sulphur industries in the 1920s, but because of that the fields are old and mainly played out. Maturing gas fields and the shale gas boom have undercut US and Canadian sour gas production and destroyed much of the economic rationale for developing new fields.

In the US, production of sulphur from sour gas was 276,000 tonnes in 2020, according to the US Geological Survey, down from 323,000 t/a in 2019. Of this, 45% came from the PADD 3 region – the US Gulf Coast – and 54% from the PADD 4/5 region – the west coast and Rocky Mountains area. This figure has declined steeply, especially in the Gulf Coast; a decade ago in 2010 US sour gas production was responsible for 1.17 million t/a of sulphur production.

It is a slightly different story in Canada. Although sour gas production has fallen in Alberta, where sour gas producers generated 1.46 million t/a of sulphur in 2020 according to the Alberta Energy Regulator

(AER) – about half the figure for 2011 – in British Columbia sour gas production bottomed out in 2018 and since then has been rising. Most of the natural gas recovered from the unconventional Montney Play Trend in BC has little to no H₂S content, though the large volumes of gas recovered still generate a reasonable quantity of sulphur. There are also fields such as Heritage with H₂S concentrations of up to 0.5% and the Birch-Nig-Umbach area has H₂S concentrations up to 2.2%. British Columbia's sour gas sulphur output rose to just over 400,000 t/a in 2020, up from 270,000 t/a in 2019. Though this is still well down on the 2011 figure of 800,000 t/a, it means that overall Canadian sour gas sulphur production actually rose in 2020 for the first time in many years, to 1.9 million t/a.

New sulphur

New sour gas projects do not dominate the forecast for new sulphur production in the way that they used to. Nevertheless, as this review reveals, there is still new capacity coming on-stream over the next few years.

In Europe and North America, production continues to decline. CRU recently forecast that Germany's Wintershall sour gas facility will close in the second half of this decade, removing almost all of Europe's remaining sour gas production. In North America, British Columbia has seen an uptick in production which may balance falling output in Alberta, but the trend is still downwards. In China, production is increasing, but not as quickly as had been anticipated a few years ago, and new output may only total 300,000 t/a of sulphur. In Central Asia, the major issue is the relative inaccessibility of the gas fields, and the consequent difficulty in exporting sulphur from the region. Kazakhstan's government has also cracked down on sulphur storage, forcing TCO to sell its stockpile. Most new sour gas projects therefore are looking to acid gas reinjection to boost oil production, although the Kashagan expansion is an exception to this. For the time being, then, it remains the Middle East where most new sour gas is being extracted, with Abu Dhabi, Saudi Arabia and Qatar the largest prospects. New sour gas sulphur production from these countries could total 3-4 million t/a by 2025, with the majority coming from the Shah expansion in Abu Dhabi. ■

CONTENTS

What's in issue 397

COVER FEATURE 1

Sour gas projects

COVER FEATURE 2

Demand for sulphur fertilizers

COVER FEATURE 3

Options for sour water stripper gas

COVER FEATURE 4

Sulphuric acid projects and technology

SULPHUR
ISSUE 397
NOVEMBER-DECEMBER 2021

BCInsight

Southbank House, Black Prince Road
London SE1 7SJ, England

Tel: +44 (0)20 7793 2567

Fax: +44 (0)20 7793 2577

Web: www.bcinsight.com
www.bcinsightsearch.com

Trends in demand for sulphur fertilizers

Sulphur is becoming an increasingly important crop nutrient, due to a combination of lower airborne sulphur emissions, the increasing prevalence of high analysis fertilizers, and higher cropping intensities.

Sulphur is present in all crops and plays an important metabolic role. It is essential for the formation of proteins, amino acids, vitamins and enzymes, and is involved in photosynthesis, energy metabolism and carbohydrate production. Sulphur also contributes to the flavour and aroma of crops such as onions and can therefore influence the quality of farm produce. Plant availability of sulphur can also govern its uptake of nitrogen, and hence limit growth. For this reason it is an important plant nutrient; on average the fourth most required soil nutrient after nitrogen, phosphorus and potassium, but much higher for some crops such as oilseed rape.

Farmers, especially in the developed world, were once used to receiving this sulphur for 'free', via atmospheric deposition caused by sulphur dioxide pollution. The crackdown on burning sulphur in power plants and road vehicles from the 1980s onwards has reduced this atmospheric

deposition to a fraction of its original value, and consequently led to many soils becoming depleted in sulphur.

At the same time, use of traditional fertilizers such as ammonium sulphate, single superphosphate and potassium sulphate have decreased, with a preference for higher analysis fertilizers such as urea, diammonium phosphate and potassium chloride. Although as Figure 1 shows, while global use of SSP has declined in absolute terms, use of ammonium sulphate and SOP has actually increased slightly, just nowhere near as much as use of other fertilizer types has.

Sulphur-enhanced fertilizers

These traditional sulphur fertilizers still represent the bulk of plant nutrient sulphur that is delivered to fields as fertilizer; perhaps 70% in 2017 according to figures from the International Fertilizer Association. However, with a growing recognition of the issue of sulphur deficiencies in soils has come a range of new sulphur containing or enhanced fertilizers which incorporate elemental sulphur into higher analysis fertilizers, either within granules or as an external coating. Introducing a liquid sulphur spray to Urea, TSP, MAP or DAP during drum or pan granulation, for example, results in N and P products with a 5-20% elemental sulphur content.

Sulphur-enhanced fertilizers combine nutrient availability with high use-efficiency, and also have good storage and handling properties. The market for sulphur-enhanced NP+S products has developed over the past decade, with particular take-up in the US, Brazil, India and parts of Africa. Shell license a micronized sulphur enhanced product as Thiogro, and this technology is now used to produce sulphur enhanced phosphates.

A related technology is used for urea enhanced sulphur, Urea-ES.

Urea can also be coated with elemental sulphur. Sulphur-coated urea combines 77-82% urea (36-38% N) with a 14-20% sulphur coating. IFA estimated the market for sulphur-coated urea to be 900,000 t/a (tonnes product) in 2016, with almost all of this market (ca 95%) in east Asia.

There are also blends. Yara offers two ammonium nitrate/calcium sulphate blends. Mosaic's MicroEssentials fertilizer range contains 10-15% sulphur in a 50-50 mixed form of both sulphate (for initial availability) and elemental sulphur to keep plants growing throughout the season. EuroChem produces urea ammonium sulphate at its plant at Novomoskovsky Azot, as well as ammonium sulphate nitrate.

Finally, sulphur can be applied in elemental granular form, though it must oxidise to sulphate to become available to the plant. HJ Baker & Bro mix it with 10% bentonite clay to cause the clay to absorb moisture and swell to break up the granule in the ground and assist with its conversion to sulphate.

For the moment, these remain relatively niche products, though their use is growing. Total demand for sulphur as a fertilizer is only about 15 million t/a, compared to over 110 million t/a for nitrogen. Nor does all of that 15 million t/a come from recovered elemental sulphur – SOP is mined as sulphate, and some SSP and AS come from smelter acid used to treat phosphate rock or produce caprolactam respectively, the latter particularly in China. However, the Sulphur Institute estimates that the global requirement for sulphur fertilizer at closer to 24 million t/a S to tackle the increasing sulphur deficiency in soils in order to achieve the kind of crop yields that the world will need in order to sustain a growing population. ■



PHOTO: DSF REFRACTORIES

As sulphur recovery units operate at progressively higher temperatures, creep stress in the furnace refractory lining can lead to deformation or even failure of the bricks and require the shutdown of the SRU. UK-based DSF Refractories have developed a product which minimises creep stress damage at high temperatures, for a longer-lived furnace lining.

The Claus process converts hydrogen sulphide into elemental sulphur in two steps. The first step is the high temperature reaction furnace, where H_2S in the gas stream is burnt in air or oxygen to convert a stoichiometric portion of it into sulphur dioxide. The second step is a series of reactors and condensers where the SO_2 reacts with the remaining H_2S to produce sulphur and steam. The overall reaction scheme is:

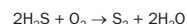

The initial combustion of H_2S to SO_2 is accomplished at very high temperatures, typically above 1,000°C. The reaction vessel is thus lined with a refractory material to protect the vessel itself, which must endure a severe thermo-mechanical and thermo-chemical environment. Traditionally, SRU refractory linings have been based on alumina (Al_2O_3). Alumina is one of the most chemically stable oxides, in both oxidative and reducing atmospheres, as well as having good strength and hardness.

Aluminas

There are numerous types of alumina; aluminium oxide can exist in several different crystal forms, though the hexagonal close packed alpha phase is almost exclusively used for ceramics because of its density and heat stability. Various additives can be

added to alumina to promote high densification. Talc (MgO) may be added to promote the formation of a liquid phase, but at certain levels can inhibit grain growth during alumina sintering which can reduce the relative rate of coarsening to densification. Other sintering additives include CuO or TiO_2 and work by causing more vacancies in the alumina lattice. These vacancies promote diffusivity and increase diffusion rates.

The percentage of alumina content in an alumina refractory can dramatically alter its properties. At the highest rates of Al_2O_3 content (>99%) there is corundum, which is the hardest form with the highest strength and resistance to erosion. However, it can be brittle and vulnerable to heat stresses, and is mostly used for low temperature or harsh wear applications. Alumina for SRU use is typically around 90% aluminium oxide, although sometimes as high as 94-95%. Lower levels of alumina are found in mullites, which are mixes of alumina and silica and contain around 70% alumina. They have the advantage of low levels of impurities, excellent volume stability and high resistance to loading in high temperatures. Finally, sillimanite refractory has an alumina content of between 50-60% with higher levels of silica than mullites. Sillimanite refractories have low creep and high refractoriness under load, and are widely used in the glass, iron and steel, petrochemical, electrical, cement, and non-ferrous metal industries.

Creep resistance

The traditional materials for SRU linings are based on 90% alumina and generally operate well. However, there has been a tendency towards higher operating temperatures for SRUs in recent years, both to cope with leaner acid gas streams, and to ensure the destruction of benzene, toluene and xylene (BTX) in the feed gas, as well as ammonia and other potential contaminants, but also via the increased use of oxygen enrichment to allow higher throughputs. BTX destruction requires temperatures of >1,200°C. Oxygen enrichment can push operating temperatures to 1,500°C or more; in reaction furnaces with 40% oxygen enrichment, steady temperatures of 1,490°C can be achieved, and a system running at 60% O_2 enrichment can increase the operating temperature to 1,510°C.

These temperatures still pose no significant threat to the stability of typical alumina linings. However, where there are abnormal process temperature excursions upwards from this level, even if sporadic and short term, they can lead to creep deformation in the most mechanically stressed parts of the lining (e.g. the top of the furnace). Multiple excursions can lead to deformation or even failure of the lining and subsequently limit the length of an operating campaign.

CONTENTS

What's in issue 397

COVER FEATURE 1

Sour gas projects

COVER FEATURE 2

Demand for sulphur fertilizers

COVER FEATURE 3

Options for sour water stripper gas

COVER FEATURE 4

Sulphuric acid projects and technology

SULPHUR
ISSUE 397
NOVEMBER-DECEMBER 2021

BCInsight

Southbank House, Black Prince Road
London SE1 7SJ, England

Tel: +44 (0)20 7793 2567

Fax: +44 (0)20 7793 2577

Web: www.bcinsight.com
www.bcinsightsearch.com

Fig. 1: Use of traditional sulphur containing fertilizers, million tonnes S per year

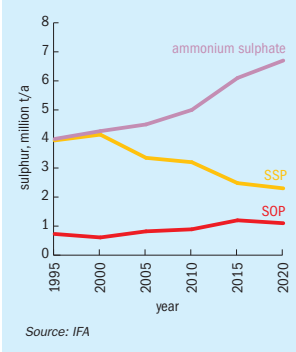

Source: IFA

Fig. 1: Alumina-silica binary phase diagram

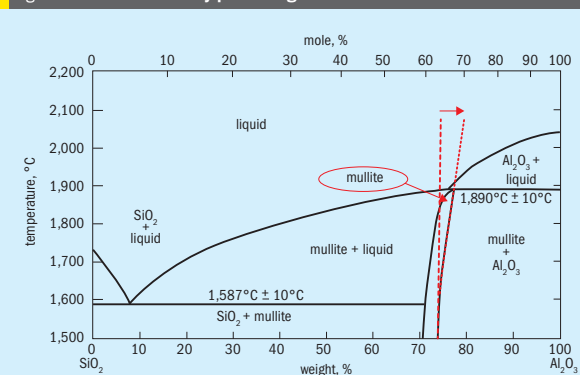

Source: F.J. Klug, S. Prochazka, and R.H. Doremus, Alumina-silica phase diagram in the mullite region, J. Am. Ceram. Soc. 70, 750-759 (1987)

Table 1: DSF *Frimul FX* properties compared to typical 90% alumina SRU lining material

	<i>Frimul FX</i>	90% alumina
Bulk density (g/cm ³)	2.62	3.05
Apparent porosity, %	16.2	16.3
Cold crushing strength, MPa	111	78
Chemical composition (%)		
Al ₂ O ₃	75.6	90.4
SiO ₂	24.2	9.28
K ₂ O	0.08	0.01
Na ₂ O	0.20	0.17
Phase composition (%)		
Mullite	96	16.6
Corundum	1	80.6
Thermal expansion 20-1,500°C, %	0.91	1.15
Thermal conductivity, @ hot face 1,000°C	14.3	18.0

Source: DSF Refractories

Frimul FX

DSF Refractories & Minerals have long supplied premium grade re-bonded fused mullite refractories for long campaigns (up to 20 years) in the glassmaking industry. The bricks are used to form sprung self-supporting crown structures, in which they are subjected to temperatures up to 1,650°C and therefore must have intrinsic thermo-mechanical stability, that is, creep deformation resistance.

Following anecdotal reports of SRU linings failing prematurely, and taking into

consideration the views of industry experts, DSF Refractories therefore decided to use their experience in these materials to develop a creep resistant mullite specifically for SRU linings. The remit for this product was to exhibit minimal creep deformation at 1,650°C. *Frimul FX* is fired to 1,700°C in batch intermittent kilns which ensures extensive solid-state bonding throughout the brick matrix. This in turn imparts structural integrity at high temperatures and loads. While *Frimul FX* is a derivative of a predecessor product; DSF *Frimul F*, the latter with proven thermo-mechanical stability over

many years, it is nevertheless also a significant step forward in materials design. *Frimul FX* is 75% alumina, which fully converts to 95% crystalline mullite on firing.

Following extensive research, the binary phase diagram (Al₂O₃:SiO₂) for these materials (Figure 1) has been reassessed, and shows that the mullite stable phase field veers toward Al₂O₃ enrichment at elevated temperatures. The *Frimul FX* composition mitigates for this phenomenon, which in conjunction with ultra-pure fused and reactive in situ bonding materials contributes to very low creep values at 1,650°C.

Physical and chemical properties

A comparison of physical and chemical properties of *Frimul FX* and a traditional mullite bonded corundum 90% alumina product is outlined in Table 1. In addition to increased creep resistance, the other intrinsic physical and thermal attributes of the ceramic positively influence lining and therefore unit stability, including a lower density compared to traditional material (around 14% lower), lower thermal conductivity and lower thermal expansion (both 21% lower than a 90% alumina material). The lower density means that a *Frimul FX* SRU lining weighs less than that constructed with traditional material. Not only does this lower the stress on the material, which can be particularly important in larger SRUs, such as in large gas plants in the Middle East, it also means that the backing thickness can be reduced without a detrimental increase in shell temperature, so overall heat loss is reduced. This maintains an appropriate shell temperature (1,75-2,90°C) to avoid both condensation of sulphuric acid at lower temperatures or sulphidation at higher temperatures. A potential decrease in backing lining thickness can also increase the overall reactor capacity by 3.4% for a 3.65 m diameter reactor.

Creep under load

DSF's main objective in development of the product was that *Frimul FX* should exceed the creep resistance of present materials and meet the future auspices of relevant API standards. To qualify this, it was specified that maximum deformation should be 0.5% between 50 and 100 hours via ASTM C832 or DIN EN 993-9 creep under load determination at 1,650°C and 25psi.

Frimul FX has been through an extensive creep testing programme encompassing both ASTM and ISO/BSEN test methods. A

summary of all tests performed at 1,650°C is shown in Table 2. There does seem to be an anomaly in the results when a cylinder specimen is tested; the deformation recorded during the test does not correlate closely to the before/after measurements which may be due to an idiosyncrasy with the measurement system. Numerous tests have also been performed at 1,600°C; at this temperature virtually no creep is observed, and the material is perceived as 'zero' creep within the constraints of experimental error and the inherent stability of the creep apparatus.

API 565

One of the hurdles DSF has had to overcome in promoting *Frimul FX* was the existing standard for SRUs; American Petroleum Institute (API) 565: Thermal Reactors for Sulphur Recovery Units in General Refinery Service. The old standard said refractories should be at least 88% alumina; a barrier to the adoption of a lower alumina mullite refractory. That section had not been updated for over 40 years, so DSF prioritised participation in the standards committee for API 565 in order to review it and judge whether it was still fit for purpose in the light of the way that the sulphur industry had changed over that time. With creep resistance becoming one of the key properties that users were looking for in a refractory, they helped develop a test for fitness for use which involved a specification of creep deformation of less than 0.5% between 50 and 100 hours at 1,650°C, which is now included in the updated standard.

Silica depletion

One of the concerns about using mullite materials was the potential for silica leaching from the refractory by hydrogen. Hydro-

DSF Refractories & Minerals

DSF Refractories was founded by local entrepreneur John West. West had established the West Gas Improvement Company in 1874 at Friden in the heart of the picturesque Derbyshire Peak District (now a National Park) to take advantage of local silica deposits, and the High Peak railway which ran adjacent to the site. The area is one of upland limestone scenery, with tertiary siliceous deposits formed as pockets filling large pits and hollows in the limestone surface. West also supplied town gas to Manchester, and founded the Derbyshire Silica Firebrick Company (later DSF Refractories) in 1892 to manufacture town gas retort shapes from locally-sourced silica and siliceous sands for the high temperature gasification sections of town gas plants. All of the company's early products were based on local silica and siliceous deposits quarried from pits in the surrounding area. Refractory shapes were either machine or hand moulded; fired and then packed in barrels for transportation. DSF still prides itself on its ability to hand-produce bespoke brick shapes for any application.

The gradual changeover from town gas to natural gas in the 1950s-70s led to a change in the company's activities from ceramics for gas applications to high alumina bricks based on bauxite, mullite and andalusite for the steel industry, which by 1977 represented 70% of the company's turnover. In 1979 a new product based on andalusite was launched for the glass industry, which was followed in 1986 by a change of ownership (to the BHF group) which heralded a new era of both product development and investment; mainly refractories for the glass industry and the addition of a modern mineral processing plant which not only supplied the requirements of refractory manufacture but also provided much needed capacity for processed mineral sales to grow.

The 1990's saw a decline in DSF's steel industry sales as the UK steel industry contracted, with basic steel ladle bricks gaining prominence over siliceous and high alumina compositions. The focus moved to the glass industry with many new products developed. Management buyouts occurred in 1992 and the 2003, the latter triggering a dynamic period of investment and growth, with supply of refractories to the glass industry. In recent years DSF has also become a significant supplier to the carbon black industry, and most recently has turned its attention to the petrochemical market.

gen production can be generated by oxygen enriched feeds in an SRU, and the presence of hydrogen in a gas feed can reduce SiO₂ containing components in refractory compositions to SiO(g) vapour phase at temperatures in excess of ~800°C via the following reaction:



The reaction affects all silica-containing materials, and therefore in regard to SRU hot face lining materials, whether mullite or mullite-bonded, the phenomenon has to be assessed. For high hydrogen concentrations (> approx. 13 vol-%), it is acknowledged that all mullite/mullite-bonded materials will suffer SiO₂ depletion. Scanning electron microscopy (SEM)

Table 2: Summary of *Frimul FX* creep tests performed at 1,650°C

Standard	Sample load (psi)	Orientation	Expansion (%)	Creep (%)		
				50-100h	Total	Before/after
DIN EN 993-9	Cylinder 29	Pressing	0.79	0	+0.02	
ASTM C832	Prism 25	Perpendicular	1.04	-0.09	-0.23	-0.19
ASTM C832	Prism 25	Perpendicular	0.96	-0.1	-0.19	-0.17
ASTM C832	Prism 25	Perpendicular	0.92	-0.04	-0.12	-0.08
DIN EN 993-9	Cylinder 29	Pressing	1.00	-0.08	-0.22	-0.05
ASTM C832	Cylinder 25	Pressing	1.07	-0.17	-0.56	-0.17

Source: DSF Refractories

Fig. 2: Hydrogen depletion of silica at front face (2 years exposure), mullite-bonded corundum

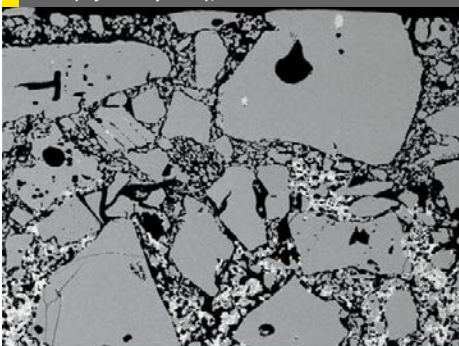

alumino-silicate D4417/RW



Al Ka1

Si Ka1

PHOTOS: DSF REFRACTORIES

Fig. 3: Hydrogen depletion of silica leaving corundum layer at front face (2 years exposure), *Frimul FX*

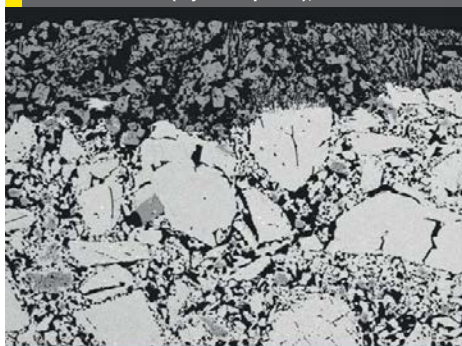

alumino-silicate D4418/RW

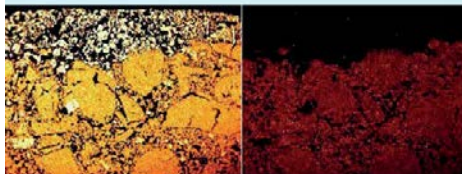

Al Ka1

Si Ka1

PHOTOS: DSF REFRACTORIES

imaging of *Frimul FX* indicates that its high firing temperature ensures extensive mullite intra- and inter-granular bonding; there is no free silica, the silicate that remains is encapsulated in the mullite matrix. The residual corundum is mainly intragranular, which under high loading actually imparts a small expansion to stabilise the material. Whilst pure Al_2O_3 is chemically the most resilient composition for hydrogen rich environments; in comparison with mullite it has poor thermo-mechanical stability and relatively high creep characteristics.

Samples of *Frimul FX* and DSF's *Fricor 95*, a more traditional mullite bonded corundum material, were placed on the working lining of a SRU (5 exposed faces) for a period of two years to investigate the interaction with hydrogen. The reaction surface was examined by SEM in back scattered and elemental mapping modes (Figures 2 and 3). The lower elemental mapping images clearly show the removal of SiO_2 from the face of the structure in both samples (red images). The process could be isokinetic, that is the depletion of SiO_2 continues at a constant rate without any barriers to the speed of the process. If

this is the case then *Frimul FX* is affected to a depth of ~1mm per annum, which is similar to *Fricor 95*, the traditional mullite bonded corundum composition.

Following consideration by industry experts, this effect was not considered as significant, due to the acknowledgment that a 25 year campaign would potentially affect only 25mm of refractory; and even in this hypothesis the load bearing stability portion of the refractory would not be compromised. Concerns about potential blockage of downstream pipework were not borne out in view of the very small quantities of silica being leached and their dilution in the gas stream.

Summary

DSF says that its *Frimul FX* represents a step change in SRU lining materials, exhibiting unparalleled creep resistant characteristics which are intended to not only meet but exceed the API standards, and more importantly define a material with capability to withstand both normal and abnormal operating temperatures. The material has been in service in an oxy-fuel fired glass melter operating continuously at 1,600°C across

the crown of the melter, with a 4m span, and in an aggressive boron-containing environment. Although the material is new to the sulphur industry, technical due diligence has been performed and to date there have been no significant parameters which would negate the use of this material.

DSF argues that using a mullite material has intrinsic benefits compared with traditional 90% alumina materials:

- Comparable maximum service temperature.
- Shell temperature is maintained in the range 175-290°C.
- Lower density, which correlates with a reduced footprint weight.
- Lower thermal conductivity, leading to the potential for thinner linings to increase reaction capacity with no significant change to shell temperature.
- Lower and linear thermal expansion; there are no peaks or troughs in the expansion curve, and therefore no heterogeneous reaction to temperature swings, specifically during power outages.
- Excellent resistance to creep at high loads and temperature providing stable lining construction. ■



Industrial Ceramics Limited

Established 1946

Industrial Ceramics LTD (ICL) has been specializing in the manufacture of tubesheet protection systems (ferrules) and other speciality shapes for over 55 years.

ICL designs are used in plants all over the world, protecting WHBs from high temperature corrosion and degradation in SRUs, Methane Reformers, Sulphuric Acid plants and other Petrochemical applications.

Technical Support includes:

- CFD modelling (to used to determine optimal design and temperature profile across the tubesheet lining)
- RCA support - We can bring our wealth of experience to your RCA team if you are having tubesheet lining reliability issues.

ICLs key market strengths are:

- Superior material properties (excellent high temperature strength and thermal shock resistance)
- Reliability
- Design
- Installation
- Technical Support



EXperience
pertise
ceptional Support

Milton, ON, Canada
+1 (905) 878-2848

www.industrialceramics.com
salesdesk@industrialceramics.com

Emergency: +1 (905) 699-9373 (6 AM - 8 PM EST) +90 (531) 858-8033 (8 PM - 6 AM EST)

A sustainable solution for sulphur waste

Left: Wheat field in the UK.

Below: The Iraq field trials were developed to further assess the feasibility of the sustainable solution for the sulphur which is the commercialisation of the sulphur product for sale into agriculture, as a fertilizer, in Iraq.



PHOTO: BCINSIGHT

PHOTO: RSK

RSK and its subsidiary ADAS have developed a sustainable solution for the disposal of sulphur waste generated from a natural gas processing facility in Iraq. **C. Teulon** of RSK reports on the research that was carried out to test whether the waste sulphur from a biological sulphur removal process could be applied in agriculture to increase the quality and quantity of crops in Iraq.

Evidence of Iraq's vast petroleum resources are seen throughout the region in the extensive oil and gas extraction and processing facilities. Iraq is committed to reduce flaring by 2030 and as part of this, infrastructure is being developed to process natural gas that would otherwise be flared. Some of this gas is sour with elevated concentrations of poisonous hydrogen sulphide (H_2S) gas. In NGL processing the H_2S is converted to elemental sulphur which is produced as a waste product. While sulphur is a commodity in international markets, the volume produced in some facilities is not sufficient to warrant investment in infrastructure to facilitate export, and the quality at over

98% pure, is not always acceptable for other chemical uses.

In petroleum-rich southern Iraq, pollution and prevention and sustainability are aspirations but implementation is less of a reality. Waste management facilities are also limited. Further, the region is ravaged by war, plagued by poverty and water is scarce. Farmers in Iraq struggle in this marginal environment and are challenged with infertile soil and extreme climates.

RSK, a leading integrated environmental, engineering, and technical services business, completed an Environmental, Health and Social Impact Assessment (ESHIA) for a proposed sour gas processing facility (400 MSCFD associated gas) in

Iraq that received funding from the International Finance Corporation. Elemental sulphur is recovered during the processing of associated gas using licensed bio-reactor technology. The sulphur produced from the process is delivered as a solid powder with a dry matter of 79.9% and total sulphur content of 98.9% (based on dry matter).

The ESHIA identified that the recovered sulphur did not have a disposal outlet and the waste management facilities in Iraq were non-existent, overcapacity, or did not meet international requirements. Even at a rate of up to 43 t/d, the volume was not enough to consider export and there was no market for elemental sulphur with these



UK pot trials



UK field trials

PHOTO: RSK

specifications in Iraq. The objective was to find an environmentally responsible solution to re-use the sulphur and divert it from existing landfills.

A detailed options analysis identified agriculture as a potential user since sulphur is a nutrient required for plant growth. A series of experimental pot and field trials in the UK and Iraq, completed in June 2020, were designed to research that hypothesis that the sulphur produced is beneficial in vegetable and cereal crops and will increase both the quality and quantity of the crops.

To research this hypothesis, RSK partnered with the University of Basrah College of Agriculture and engaged with ministries, industry stakeholders and farmers, while providing new learning and development opportunities for Iraqis.

The results showed that sulphur waste from a biological sulphur removal process could be applied to major crops in Iraq to increase yield and quality. Further the sulphur waste could be diverted from landfills while improving the bottom line for both the gas processor and the farmers.

Full physical (including spread assessments) and chemical characterisation on the waste sulphur concluded the sulphur was:

- non-hazardous;
- did not contain heavy metals;
- did not contain hydrocarbons;
- non-leaching;
- 60 – 75 % dry matter content;
- > 99.8% sulphur and the remainder biomass <0.2%;
- median diameter (D50) of 5.75 μ m (rapid oxidation and uptake to plants);
- does not show hydrophobic behaviour typical of chemically produced sulphur.

UK pot trials

Pot trials were carried out by environmental consulting company ADAS in polytunnels in the UK to characterise the sulphur fertilizer. The specific objectives of the experiment were to:

- quantify the rate of oxidation of elemental sulphur to crop available sulphate in three contrasting soil types;
- measure any change in pH following application of elemental sulphur in three contrasting soil types;
- provide an initial test of crop response to elemental sulphur of oilseed rape, wheat and grass grown in three contrasting soil types.

The pot experiment provided valuable data on the availability of soil sulphur for plant uptake and impact on soil pH of the sulphur. The pot experiment concluded:

- sulphur has not had a significant impact on soil pH;
- sulphur oxidised fast, and was available for plant uptake at a rate that was at least equal to soluble forms of sulphur;
- sulphur had no negative impact on plant growth.

UK field trials

The UK field trials consisted of experiments designed to characterise the sulphur fertilizer compared to other more commonly used water-soluble sulphur fertilizers and assess whether application of sulphur to a range of crop types increases crop yields/quality.

Sulphur response field experiments were carried out at three sites cropped

with winter oilseed rape in 2019. Winter oil seed rape was selected for this work as it is known to be responsive to sulphur fertilizer and therefore provides a good test crop for these experiments.

All sites showed a yield response to applied sulphur ranging from 0.2 to 1.8 ton/ha. Yield increases were measured from both the sulphur and ammonium sulphate fertilizer treatments at each site, supporting the use of sulphur as a source of fertilizer sulphur. Yield increases from the sulphur ranged from 0.1 to 1.6 t/ha.

The research suggested that the sulphur fertilizer is at least as effective as a water-soluble sulphur fertilizer in supplying sulphur to plants grown in pots.

Iraq pot trials

The objectives of the pot experiment undertaken by the University of Basrah in 2019 were to:

- provide an initial test of the crop response to sulphur on four representative crop species (sunflower, okra, corn, beans);
- measure the impact of sulphur application on soil pH and electrical conductivity.

The pot experiments included:

- three soil types (silty clay, sand, silt);
- three sulphur application rates (0 kg/ha, 64 kg/ha and 6 t/ha);
- two organic matter application rates (0% and 5% by dry weight).

The Iraq pot trials concluded:

- a significant effect on pH was observed for all crops, with a significant reduction of pH at rate of 6 t/h as compared

CONTENTS

What's in issue 397

COVER FEATURE 1

Sour gas projects

COVER FEATURE 2

Demand for sulphur fertilizers

COVER FEATURE 3

Options for sour water stripper gas

COVER FEATURE 4

Sulphuric acid projects and technology

SULPHUR
ISSUE 397
NOVEMBER-DECEMBER 2021

BCInsight

Southbank House, Black Prince Road
London SE1 7SJ, England

Tel: +44 (0)20 7793 2567

Fax: +44 (0)20 7793 2577

Web: www.bcinsight.com
www.bcinsightsearch.com



PHOTOS: RSK

to the rate of 64 kg/ha (pH reduction in the Iraqi soil is important for soil conditioning);

- application of sulphur accompanied with 5% organic matter improved performance of corn, sunflower, and okra grown in all three soil types and alleviated sulphur deficiency;
- sulphur had no adverse effect on growth of crops under study at all soil types.

Iraq field trials

The Iraq field trials were developed to further assess the feasibility of the sustainable solution for the sulphur which is the commercialisation of the sulphur product for sale into agriculture, as a fertilizer, in Iraq.

The objectives of the field experiments in southern Iraq were to assess the response of vegetable and cereal crops (tomato, onion, wheat, and barley) to added sulphur (0 kg/ha and 80 kg/ha) in terms of growth/yield and availability of sulphur in soil.

The Iraq field trials concluded:

- sulphur is a good source of crop available sulphur;
- tomato, onion, wheat and barley crops showed a positive yield response to applications of sulphur;
- ascorbic acid content in tomato (a quality metric) increased with the use of sulphur;
- grain yield and quality of wheat and barley were enhanced by addition of organic matter and sulphur;
- sulphur accompanied with increasing nitrogen and sulphur availability and uptake maximised yield quality of crops.

Conclusions and next steps

The UK and Iraq field experiments showed yield increases and benefits to crop quality from the application of sulphur, demonstrating that the product is a good source of crop available sulphur. The Iraq field experiments showed significant benefits to yield and crop quality across a range of crop types, which demonstrates that sulphur deficiency does limit crop yields in Iraq and that sulphur can be used as a source of sulphur to support Iraqi agriculture.

Next steps include assessment of several options for the supply and application of sulphur in Iraq:

- supply the powdered sulphur as a raw material to another fertilizer manufacturer for processing into a fertilizer product, most likely a multi-nutrient fertilizer product (solid or liquid);
- Process the sulphur into a liquid suspension fertilizer;
- process the sulphur into a granulated fertilizer product which can be applied using conventional fertilizer application equipment;
- supply the sulphur to chemical manufacturers.

Acknowledgement

RSK gratefully acknowledges the support and contributions from the following: Dr Lizzie Sagoo, ADAS; Dr Peter Berry, ADAS; Dr Mohsen Disher, University of Basrah; Dr Rashad Adil Imran, University of Basrah; Dr Hayfaa Jasim Hussein, University of Basrah; Dr Najlah Jebur Mohammed, University of Basrah.

The objectives of the field experiments in southern Iraq were to assess the response of vegetable and cereal crops with and without added sulphur.



PHOTO: RSK

Desmet Ballestra offers design and supply of plants and relevant field services for the production of sulphuric acid, oleum, SO₂ and SO₃.

- Permanent licensee of DuPont MECS® for major sulphuric acid/oleum units
- Proprietary technologies and know-how for small sulphuric acid/oleum and SO₂/SO₃ units
- Updated DuPont MECS® HRS™ system for enhanced heat recovery
- Tail gas cleaning systems and emissions control
- Wide range of production capacities and customized solutions according to specific customers' requirements
- Spare parts and technical assistance support worldwide

Over 25 units have been successfully delivered and installed worldwide.



Science behind Technology

desmet ballestra

Desmet Ballestra S.p.A. - Via Piero Portaluppi 17 - Milan - Italy - mail@ballestra.com

www.desmetballestra.com

CONTENTS

What's in issue 397

COVER FEATURE 1

Sour gas projects

COVER FEATURE 2

Demand for sulphur fertilizers

COVER FEATURE 3

Options for sour water stripper gas

COVER FEATURE 4

Sulphuric acid projects and technology

SULPHUR
ISSUE 397
NOVEMBER-DECEMBER 2021

BCInsight

Southbank House, Black Prince Road
London SE1 7SJ, England
Tel: +44 (0)20 7793 2567
Fax: +44 (0)20 7793 2577
Web: www.bcinsight.com
www.bcinsightsearch.com

Sulphuric acid projects and technology

Developments in sulphuric acid technology and engineering know-how are highlighted by recent project case studies from DuPont Clean Technologies, Metso Outotec and thyssenkrupp Uhde.

DUPONT CLEAN TECHNOLOGIES

AZFC Unit 6 revamp project

By 2015, the Unit 6 sulphur burning plant operated by Abu Zaabal Fertilizer and Chemical Company (AZFC) had been in service for 31 years. Unsurprisingly, three decades of operation at the company's fertilizer production complex in Egypt's Qulubia Governorate had taken their toll. Due to a host of problems, including corrosion, sulphate build-up and gas leaks, the unit was experiencing daily

downtimes, multiple shutdowns and significant losses in production.

AZFC had originally considered shutting the plant down when its new Unit 7 was commissioned in 2009. But rising demand for phosphoric acid meant the company needed the extra capacity. The time had clearly come for a complete revamp. AZFC decided to act and selected DuPont Clean Technologies (DuPont) as a partner to

revamp the acid plant and re-design the acid towers.

The AZFC production complex, owned by Polyserve Group, was first commissioned in 1984 and includes two sulphuric acid production plants – Unit 6 and Unit 7. Unit 6 had been AZFC's workhorse. In its time, 18 million tonnes of single superphosphate (SSP) fertilizer had been manufactured from more than six million tonnes of sulphuric acid yielded by the unit. Unit 6 had also produced over 600 million kW of clean electricity over its lifetime, allowing AZFC to cut CO₂ emissions by 11,000 tonnes.

The decision to revamp Unit 6 was not an easy one to make, as Dr Eng Sherif El-Gabaly, chairman of AZFC, explains: "Unit 6 produces around 30% of AZFC's sulphuric acid. We therefore wanted to keep the shutdown to a maximum of 12 months. We needed a reliable and experienced partner who could oversee the project and support us with any technical issues. Given the experience, references and success DuPont had with similar projects, AZFC chose DuPont."

As well as resolving productivity issues, the overhaul of Unit 6 would enable AZFC to meet newly introduced Egyptian emissions regulations. These cut permissible SO₂ emission limits from 1,500 mg/m³ to 450 mg/m³ for new plants and to 800 mg/m³ for existing plants.

Before the revamp

The list of challenges facing AZFC was long. The original brick-lined drying and absorption towers were in very poor shape with visible signs of deterioration. In particular, acid leaking from the bottom of the vessels and at the outlet nozzles of the acid tower was causing sulphate build-up and severe corrosion.

Sulphate build-up on the tube sheet of the mist eliminators in the inter-pass absorption tower (IPAT) was also triggering shutdowns and causing corrosion. Additionally, sections of the old brick tower lining were regularly coming loose and falling into the acid cooler, leading to further leakage from cooler pipes. The furnace baffles had also fallen over. This suggested that the gas was not mixing sufficiently, and that sulphur was entering downstream equipment and causing corrosion.

AZFC was not only concerned about the acid towers at Unit 6. Severe corrosion on cast iron piping, notably on the elbow of the IPAT, had created a number



AZFC's Unit 6 after the revamp project.



Above left: AZFC's Unit 6 before the revamp – the drying and absorption towers were in very bad shape. Above right (top and bottom): Acid was leaking from the bottom of the acid tower, causing corrosion issues.

of holes. Because the pipes were very heavy, installed at height and difficult to access, repairs were problematic and led to extended downtimes.

This was not all, either, as the following issues also needed to be put right:

- a significant plume from the stack;
- gas leaks from the shell of the cold heat exchanger;
- missing refractories in the waste heat boiler;
- corrosion on the tube sheet bundle and expansion joint of the boiler jug valve;
- unsafe demineralised water tanks due to corrosion.

Sometimes, the plant was shut down three to four times per day to attend to these myriad problems. Controlling the old plant had thus become extremely difficult and unsafe.

The revamp

As part of the revamp project, DuPont was asked to:

- re-design and install new acid towers and reduce overall SO₂ emissions;
- improve converter performance;
- provide site supervision during the installation of MECS® equipment.

The new high-efficiency acid towers included modern UniFlo® acid distributors in corrosion-resistant MECS® ZeCor®-Z alloy as well as MECS® Brink® mist eliminators.



A view of the MECS® Brink® mist eliminators in the new acid tower.

CONTENTS

What's in issue 397

COVER FEATURE 1

Sour gas projects

COVER FEATURE 2

Demand for sulphur fertilizers

COVER FEATURE 3

Options for sour water stripper gas

COVER FEATURE 4

Sulphuric acid projects and technology

SULPHUR
ISSUE 397
NOVEMBER-DECEMBER 2021

BCInsight

Southbank House, Black Prince Road
London SE1 7SJ, England

Tel: +44 (0)20 7793 2567

Fax: +44 (0)20 7793 2577

Web: www.bcinsight.com
www.bcinsightsearch.com



PHOTOS: DUPONT CLEAN TECHNOLOGIES

Left: The new tower as it is lifted into place at Unit 6. Right: Since start-up, Unit 6 has operated to performance guarantees, producing up to 640 t/d of acid.

DuPont also introduced new **MECS® GEAR®** catalyst for increased conversion and supplied hard-wearing **MECS® ZeCo^r-Z** acid piping for the acid towers and the drying tower mesh pad.

As well as guaranteeing a sulphuric acid production rate of 615 t/d, the aim was to also achieve SO₂ emission targets of less than 800 mg/Nm³, as well as SO₃ absorption and SO₃/acid vapour emission control levels of less than 35 mg/Nm³.

The revamp began in late 2015 with the dismantling of the old acid towers and repairs to the foundations. The new carbon steel tower vessels were fabricated off-site by local engineering company ASF-EL Sewedy Industries Group and transferred to Abu Zaabal in three sections – where they were then welded, lifted into place, and erected in a simple operation.

Highly corrosion-resistant **MECS® ZeCo^r-Z** alloy was used for pipes, all elbows, bends, fittings and spool pieces. Their installation was carried by local engineering company IEMSA construction, whose welders had been qualified by DuPont.

Mr Abd El Hafeiz recalls: “Throughout the project, DuPont not only provided the process design and engineering for the acid towers, but also supported the revamp in an advisory role, and assisted us with the start-up of the plant.”

During the revamp, most of the cast

iron internals for the first pass converter, such as support grids and columns, were also replaced, and new woven wire screens installed for all passes. When the brick lining had been restored, the converter was then loaded with the new **MECS® GEAR®** catalyst. The revamp further included:

- repair of the main blower and almost all rotating equipment;
- fitting of seven new gas valves;
- a new gas duct for the IPAT;
- re-tubing of the cold inter-pass heat exchanger;
- a pristine demineralised water plant;
- the creation of a modern control room.

Success

The entire multi-million project was managed in a very short delivery time by AZFC’s Ayman Abd El Hafeiz and Hassan Hussein, the coordinating manager, project department. The revitalised Unit 6 successfully started up on the 15th November 2016 after a shorter than anticipated shutdown. The full revamp was concluded on budget, on time and without a single incident or injury.

Since start-up, Unit 6 has operated to performance guarantees, producing up to 640 t/d of sulphuric acid. The revamped unit had its first cold shut down for maintenance in December 2019, following more than three years’ operation. For its budget

of \$6.5 million, AZFC now has a highly effective plant at between one-fifth to one-tenth of the cost of a new plant, but with the same life expectancy.

Unit 6 revamp achievements

- The plant’s average sulphuric acid production capacity increased from 480 t/d to 640 t/d
- Stack SO₂ emissions decreased from 2,000 mg/Am³ to < 600 mg/Am³
- Plant availability improved with reduced downtime
- Downtime average pre-revamp (average over 2 years) = 1.38 days per year
- Downtime average after revamp = 3.9 days per year
- Improved availability has eliminated LE 59 million per annum (\$3.8 million p.a.) in lost sulphuric acid sales over that period
- Loss in production cut from 41.7 percent in 2014 to 0.87 percent in 2019.
- A step change in plant reliability
- The revamped plant ran for more than three years before the first cold shutdown, compared to shutdowns every 4-6 months previously
- No injuries or accidents during the entire revamp project
- A sparkingly clean and pristine plant with even roses now cultivated on site.

METSO OUTOTEC

Mazidagi project, Turkey

Collin Bartlett of Metso Outotec and Kenan Soybelli of Eti Bakir A.S.

Cengiz Holding acquired Eti Bakir from the Turkish government in 2004 with a clear strategic aim: to build an industrial complex in the Mazidagi district of Mardin, Turkey – one that combined fertilizer production with metals processing at a single location. This plant was designed to create a high level of energy self-sufficiency by efficiently capturing energy from the various unit processes on site. The Mazidagi project concept, by successfully delivering a truly integrated production complex, has set a new benchmark for future plant designs.

With the Mazidagi production complex now fully operational, Eti Bakir has fulfilled its ambition to increase the contribution domestic production makes to Turkish fertilizer demand – a strategically critical objective for a country whose large agricultural sector has (to date) relied on large volumes of fertilizer imports. Crucially, it has been the additional revenues from metals recovery that have made the Mazidagi project economical.

Metso Outotec was chosen as the key technology partner for the Mazidagi pro-



PHOTO: METSO OUTOTEC/ETI BAKIR

Mazidagi’s sulphuric acid plant.

ject as its technology portfolio was able to cover a large proportion of key plant sections for the industrial complex (Fig. 1, sections in dark green). In this case study, we focus on the technology applied in the interconnected pyrite roasting, off-gas cleaning and sulphuric acid production section (Fig. 1, highlighted in yellow).

The Mazidagi production complex

The Mazidagi complex, which takes its names from its location in the Mazidagi district of Mardin province in Turkey, was built at an investment cost of approximately \$1.1 billion, making it the highest budgeted project in Eastern Turkey.

Fig. 1: Mazidagi project: Overall flowsheet and Metso Outotec’s scope (dark green). Sections covered in this case study are highlighted in yellow

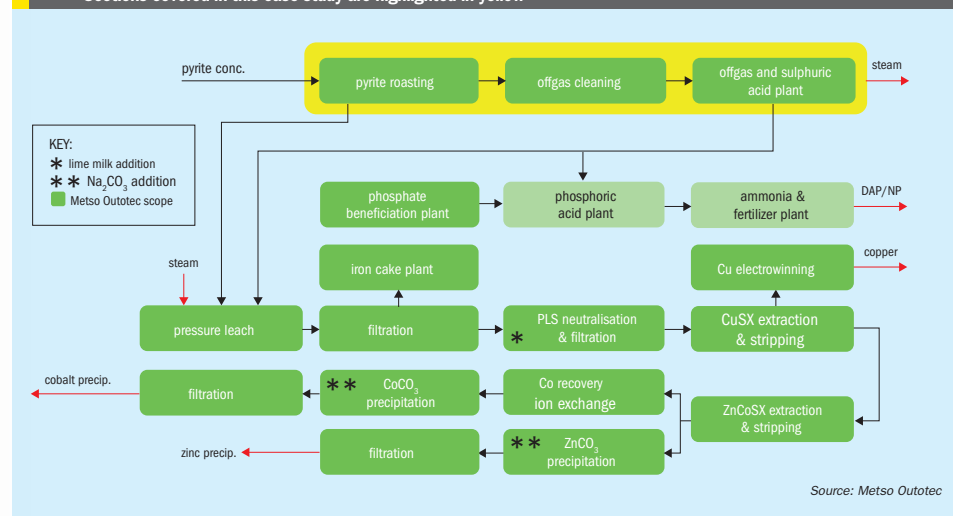

Source: Metso Outotec

CONTENTS

What’s in issue 397

COVER FEATURE 1

Sour gas projects

COVER FEATURE 2

Demand for sulphur fertilizers

COVER FEATURE 3

Options for sour water stripper gas

COVER FEATURE 4

Sulphuric acid projects and technology

SULPHUR
ISSUE 397
NOVEMBER-DECEMBER 2021

BCInsight

Southbank House, Black Prince Road
London SE1 7SJ, England
Tel: +44 (0)20 7793 2567
Fax: +44 (0)20 7793 2577
Web: www.bcinsight.com
www.bcinsightsearch.com

Construction began in the first-quarter of 2015 and was completed in the first-quarter of 2019, with the project entering commissioning after 50 months and 20 million person-hours.

The complex incorporates six key production units (Fig. 1):

- pyrite roaster/off-gas/sulphuric acid plant;
- phosphate beneficiation plant;
- phosphoric acid plant;
- ammonia plant;
- fertilizer plant;
- hydrometallurgical plant.

Additionally, a relatively large number of auxiliary utilities are also required to efficiently operate this integrated facility, namely:

- demineralised water production plant;
- chemical water treatment plant;
- water cooling plant;
- condensate purification plant;
- steam turbine and gas engine;
- auxiliary boiler;
- natural gas distribution stations;
- air compressor plant;
- pyrite and ash transport units;
- fire reservoir and distribution system;
- main water tank and water wells;
- switchyard;
- packaging facility.

The Mazidagi complex consumes 550,000 tons of locally-extracted phosphate rock and processes this to produce 750,000 tonnes of fertilizer annually. This includes 200,000 tonnes of diammonium phosphate (DAP) and 550,000 tons of NP products. Being the only fertilizer plant in the region, Mazidagi meets the entire fertilizer requirements of the surrounding Haran Plain. The plant's overall share of the Turkish phosphate fertilizer market will be 20 percent initially.

Roasting plant

In specific cases, pyrite roasting provides a viable alternative to sulphur burning as a source for sulphuric acid production, especially when pyrite is available from local sources. This is especially true for a land-locked location such as Mazidagi, where the logistics associated with supplying sulphur to the plant are particularly challenging.

The standard processing technology for pyrite is roasting in a fluidised bed reactor, as has been used on a commercial scale since the 1950s. While the principles of roasting remain unchanged, process control technology for roasting plants

Table 1: Mazidagi project: roaster plant process data

Plant feed: 1,500 t/d pyrite	
Pyrite composition	
S	48%
Fe	46%
Cu	0.5%
Co	0.5%
Zn	0.2%
Roaster configuration:	
2 x 750 t/d lines, each with 123 m ² bed area	
Calcine: total 45 t/h (S <0.6 wt-%)	
HP steam (WHB):	
Total 129 t/h (60 bar, 400°C)	

Source: Metso Outotec

has advanced and improved greatly. In the past, environmental and safety standards were often the driving forces behind improvements in equipment and plant design. Today, however, the emphasis has shifted to plant efficiency and optimisation – as delivered via Metso Outotec's advanced process control philosophy. In recent times, responsibility for plant control and operation, traditionally the domain of owner/operators, has also shifted to process technology companies due to their

ability to offer both integrated digital tools and specific process know-how.

Within the Mazidagi complex, the roasting plant fulfils two fundamental process objectives:

- Firstly, to provide an SO₂ off-gas source for sulphuric acid production
- Secondly, to produce a calcine capable of being processed in the downstream hydrometallurgical complex.

These dual process requirements meant there was a need to monitor and control roaster plant operations to ensure that – based on the composition of the concentrate, the operating temperature and the atmospheric conditions – roaster product quality remained constant.

Temperature control at this roasting plant was a key factor, given that different types of metals were being recovered, and was therefore best handled by an optimisation system. Excessively high roasting temperatures, for example, could potentially lock-up sub-microscopic particles in the calcine, while too low temperatures might negatively affect overall plant performance. Good process control was therefore of the utmost importance.

For the Mazidagi project, Metso Outotec applied state-of-the-art digitalisation tools for process monitoring, control and advisory activities – to ensure the best available support for commissioning of the plant. This was

Fig. 2: Roaster plant configuration for monitoring, control and optimisation

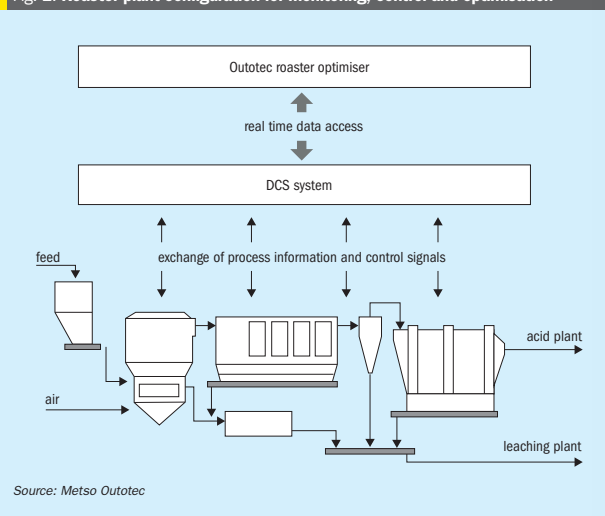

Source: Metso Outotec

achieved by installing proprietary *Roaster Optimizer* technology at the roaster plant.

The *Roaster Optimizer*, configured with Metso Outotec's advanced process control (ACT) platform, functions independently from the plant's distributed control system (DCS) (see Fig. 2), and DCS functionality therefore remains untouched. Instead, the role of the *Roaster Optimizer* is to read process values from the DCS, use these to calculate an optimised solution for plant operation, and then send back optimised values – such as feed rate, airflow or water addition rate – to the DCS.

Gas cleaning and sulphuric acid plants

The gas cleaning plant plays a central role in the smooth and efficient operation of a metallurgical sulphuric acid complex.

Nowadays, with most prime global deposits depleted, metal producers are increasingly having to process complex ores and concentrates. This often involves the dual challenge of extracting less valuable metals at higher production costs. In many cases, complex ores and concentrates are also associated with potentially polluting contaminants (e.g. arsenic and mercury) whose concentration tends to increase as the desired metal content reduces.

Given the challenging nature of complex ores, as highlighted above, the design of the gas cleaning plant clearly needs to consider all eventualities regarding off-gas impurities. For the Mazidagi project, the purity of the sulphuric acid required for downstream fertilizer production was another key consideration.

Dry/hot gas cleaning is the first gas cleaning step downstream of the roasting process. This involves removing any solid dust emitted by the process with the highest possible efficiency – generally by employing hot electrostatic precipitators (Hot-ESP).

The dedusted off-gas then enters the wet gas cleaning plant where the remaining impurities are removed using Metso Outotec's Oventox scrubber and packed gas cooling tower. This traditional and well-proven configuration is coupled with

Table 2: Mazidagi project: gas cleaning plant process data

Gas flow from roasting units	152,000 Nm ³ /h
SO ₂ concentration	12.6 vol-%
Temperature	350°C

Source: Metso Outotec



Mazidagi's gas cleaning plant section.



Mazidagi's roasting-gas cleaning-acid plant sections.

primary and second stage Editube wet electrostatic precipitators (Wet-ESP). Mercury is the main volatile generated by the roaster. This is removed via Metso Outotec's B-N mercury removal system, which remains the benchmark technology for the industry. Once it has been processed in the wet gas cleaning section, the off-gas is then suitable for further handling by a conventional sulphuric acid plant (see main photo).

Summary

Cengiz's \$1.1 billion investment in the Mazidagi metal recovery and integrated fertilizer project provided Metso Outotec with the opportunity to showcase process technologies that encompass the complete value chain at one production complex.

For the roasting plant-gas cleaning plant-sulphuric acid plant section at the Mazidagi complex (Fig. 2), Metso Outotec's successfully implemented proven process technologies that demonstrated the following advantages:

- adaptable to specific process conditions – being adjustable with respect to the complex mineralogical composition of the pyrite ore and the fine particle-size distribution of the feed material;
- integration of a state-of-the-art ACT optimiser – complementary to the plant's control system;
- installation of a gas cleaning system – capable of conditioning the off-gas to produce sulphuric acid quality suitable for use in the downstream fertilizer complex;
- installation of a sulphuric acid plant with a low pressure (LP) steam system – to complement the steam produced from the roaster plant.

After Mazidagi's successful start-up, the operators expressed their satisfaction with the smooth operability of the plant. The project detailed in this case study demonstrates Metso Outotec's proven abilities in developing and improving roasting, gas cleaning and sulphuric acid technologies with every new plant design.

Table 3: Mazidagi project: sulphuric acid plant process data

Sulphuric acid production:	2,080 t/h
Sulphuric acid quality:	As <0.1 mg/kg acid, Hg <1 mg/kg acid
Plant emissions:	<2 kg SO ₂ / t acid
Low pressure (LP) steam (HEROS™):	20 t/h (7 bar g), 170°C

Source: Metso Outotec

- CONTENTS
- What's in issue 397
- COVER FEATURE 1
- Sour gas projects
- COVER FEATURE 2
- Demand for sulphur fertilizers
- COVER FEATURE 3
- Options for sour water stripper gas
- COVER FEATURE 4
- Sulphuric acid projects and technology

THYSSENKRUPP UHDE

Small scale sulphuric acid plants – availability first

Dr Zion Guetta, Dr Holger Thielert, Dr Dirk Koester

Small-scale sulphuric acid plants offer an environmentally, technically and commercially feasible way of converting sulphur-containing off-gases (acid gases) into a valuable product. The sulphuric acid produced in these plants can be used directly as a feed material to produce marketable fertilizers, such as ammonium sulphate or potassium bisulphate.

A small-scale sulphuric acid plant will produce approximately 10-200 t/d of acid. In the design of large-scale acid plants, heat recovery is the focus, as this significantly impacts on plant profitability. Small-scale sulphuric acid plants, in contrast, require a plant design that provides maximum availability, trouble-free operation and minimal maintenance. This allows operators to focus on their core product – the production of coke or pulp, for example.

In this article, we highlight an alternative process design for small-scale

sulphuric acid plants, along with recommendations for specific equipment. This draws on the long-term experience gained from running a small-scale sulphuric acid plant. This reference plant has been on-stream and operating trouble-free for almost 40 years. Under continuous operation, its catalyst service time, without screening, is higher than 15 years.

General approach

For acid plants, process and mechanical design should focus on known criteria which affect plant availability, for example:

- Corrosion allowances, type of alloys and fouling allowances – as these have a direct impact on the service time and maintenance type of each equipment or pipe.
- Equipment manufacturers – some have better availability of spare parts and some have longer service time.

- Mechanical design – particularly the handling of the cold spots, as these can induce acid condensation and ultimately result in corrosion.

Given that the above criteria are the bread and butter of plant design, even more can be achieved at process level.

Alternative process design

Conventional sulphuric acid plants consist of combustion, conversion and absorption sections. The small-scale alternative process design (Fig. 1) also includes an additional post-combustion gas cleaning step. Gas cleaning can be carried out dry or wet, although wet cleaning is most efficient.

In the alternative sulphuric acid process, acid gas and air are combusted in a chamber to form SO_2 . The resulting heat of combustion is recovered by the

Fig. 1: Process flow diagram for thyssenkrupp Uhde's alternative sulphuric acid process – strong acid from wet acid gas

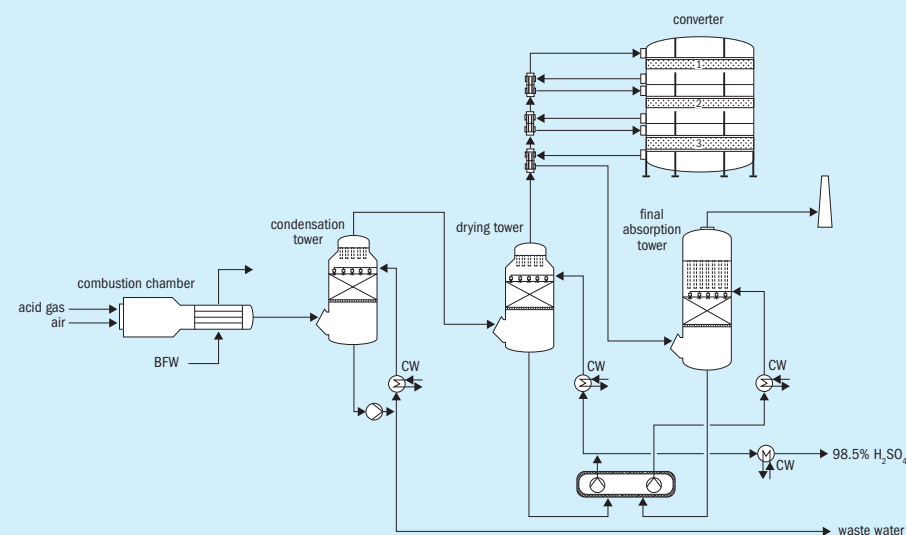

Source: thyssenkrupp Uhde

medium pressure (MP) boiler. Downstream of combustion chamber, the gas enters the condensation tower to remove water vapour and wash out any dust. The cleaned gas is then completely dried in the drying tower (using sulphuric acid) before entering the converter where it is reacted with oxygen over a catalyst to form SO_3 . The final acid is produced in the final absorption tower downstream of the converter. Typically, the off-gas leaving the final absorption tower will not require additional treatment.

This alternative process design offers clear advantages in terms of availability, compared to plants without gas cleaning, as has been demonstrated by the long-term operational history of a reference plant. The plant's operators report that no catalyst screening or change in catalyst has been necessary in 15 years of operation. For this plant design, therefore, the availability of the converter section is six times higher than for a conventional system.

Advantageously, the alternative process design also avoids specific or proprietary equipment or material design. This allows generic repairs or replacements to be arranged with appropriate local service providers and manufacturers.

A small drawback of the alternative process is the reduced potential for heat recovery, compared to a conventional process. This is because recovered heat is mainly required to preheat dry gas before it enters the converter, while in conventional processes it can be recovered for steam production. Despite this, in small capacity plants, the heat recovery potential is negligible, and more than offset by the equipment savings and the value gained from higher availability and lower maintenance costs.

Equipment maintenance

Pumps and acid coolers – similar to the catalyst in a conventional plant – do require frequent maintenance in the alternative process design. This can be compensated for by adopting equipment redundancy (duplication) to ensure full availability. Indeed, '1+1' equipment redundancy has been successfully applied as common practice at the reference plant, i.e. while one item is in operation a replacement item is always held in stock.

Additionally, the combustion burner process unit requires regular maintenance due to the corrosion associated with acid gas combustion. The presence of corrosive as well as solidifying components, like ammonia with hydrogen sulphide and naphthalene, respectively, are a particular challenge. Nevertheless, the burner developed for the reference plant by Uhde and its partners shows no requirement for wear parts after ten years in operation. This burner features a special mechanical design as well as its own dedicated control system.

Summary

Process design should always match up to long-term project requirements. In many ways, therefore, selecting the optimum sulphuric acid process for a specific project is similar to the everyday choice between a bicycle, car or truck: as different types of sulphuric acid process serve different purposes and fulfil different expectations regarding efficiency and availability. For projects focused on high availability and low maintenance costs, thyssenkrupp Uhde's alternative sulphuric acid process design offers key advantages.

Dry granulation of fertilizers

Our technology has been recognized around the world for dry granulation of MOP/SOP and NPKs. Our services cover pilot plant tests, basic engineering, equipment supply, start-up supervision, and commissioning. Typical flake capacities are in the range of 10–130 t/h or more.

We have received orders for more than 100 fertilizer compactors of latest Köppern technology since the year 2000. The total installed flake capacity of these plants is around 80,000,000 tpa.

Köppern – Quality made in Germany.

- State of the art technology
- Process technology know-how
- High plant availability
- Quick roller replacement

www.koepfern.de

CONTENTS

What's in issue 397

COVER FEATURE 1

Sour gas projects

COVER FEATURE 2

Demand for sulphur fertilizers

COVER FEATURE 3

Options for sour water stripper gas

COVER FEATURE 4

Sulphuric acid projects and technology

SULPHUR
ISSUE 397
NOVEMBER-DECEMBER 2021

BCInsight

Southbank House, Black Prince Road
London SE1 7SJ, England

Tel: +44 (0)20 7793 2567

Fax: +44 (0)20 7793 2577

Web: www.bcinsight.com
www.bcinsightsearch.com

Sour water stripping gas processing options

M. Rameshni and S. Santo of RATE discuss different sour water stripping gas processing options, depending on contaminants in the sour water streams and site-specific requirements.

In refineries, sour water is produced from different processes and units e.g. from naphtha and diesel hydrotreating and the delayed coker units. The sour water stripper removes hydrogen sulphide (H_2S) and ammonia (NH_3) from the sour water generated in the refinery. Steam, generated in the reboiler, heats the water, and strips the H_2S and NH_3 from the water.

The sour water streams produced by distillation and delayed coking units are often referred to as phenolic water, while the sour water stream produced by the hydrotreating units are often referred to as non-phenolic water.

The sour water from delayed cokers contains H_2S , NH_3 , and CO_2 , water, phenol and cyanide. The sour water from the hydrotreater contains H_2S , NH_3 , CO_2 and water.

In other words, in addition to H_2S , NH_3 , and CO_2 , phenolic sour water may also contain so-called heat stable salts (HSSs), hydrogen cyanide, and phenols. The presence of these components can adversely affect the ability to strip ammonia and H_2S .

Due to the solubility of ammonia in water, and other impurities, the design of the phenolic sour water stripper is different from the non-phenolic sour water stripper:

- higher reboiler duty;
- more trays and higher efficiency trays;
- phenolic treated water cannot be used as process water as it would damage the hydrotreater catalyst;
- the overhead system of phenolic and non-phenolic SWS may be designed differently to prevent the buildup in the SWS.

The phenol and cyanide in the delayed coker sour water are highly soluble in water and very difficult to strip out. The treated water still contains some of these components and should not be recycled to the hydrotreater because it will damage the hydrotreater catalysts and cause

corrosion. The sour water from the delayed coker is therefore treated separately in a separate SWS. No reflux is recycled to the tower to prevent the buildup of phenol and cyanide. The tower overhead is condensed in the overhead and is usually routed to the sulphur recovery unit (SRU) for further treatment.

In the design case, the stripped water must comply with the following specifications:

- Maximum H_2S content (wt ppm): <1
- Maximum NH_3 content (wt ppm): 10

For a grassroots refinery design, in most cases the refinery would have a phenolic and non-phenolic sour water stripper, where the overhead gas is sent to the SRU; non-phenolic water from the bottom of the SWS tower can be recycled to the hydrotreating unit, but phenolic water from the tower is sent to another unit for further treatment.

Historically, it has been normal industry practice in most cases to process the sour water in a single column the so-called sour water stripper. The overhead of the SWS containing the sour gases (SWS gas) is sent to the thermal reactor of the sulphur recovery where a high intensity burner is used for the destruction of NH_3 , H_2S , hydrocarbons, phenol, and cyanide. It is anticipated that with proper design the combustion temperature of the burner will be adequate for complete destruction of impurities such as phenol, cyanide, and heavy hydrocarbons.

The so-called treated water from the bottom of the sour water stripper is sent to the water treatment system for further processing.

In some refineries, especially in the US, a two-stage sour water stripper is used to separate the ammonia from the H_2S . The recovered H_2S is sent to the SRU, and the

recovered ammonia is sold to the fertilizer coker is therefore treated separately in a separate SWS. No reflux is recycled to the tower to prevent the buildup of phenol and cyanide. The tower overhead is condensed in the overhead and is usually routed to the sulphur recovery unit (SRU) for further treatment.

Different sour water stripper options are listed below:

- single-stage sour water stripping, non-phenolic water;
- single-stage sour water stripping phenolic water;
- two-stage sour water stripping in series for phenolic water to strip phenol and cyanide;
- SW-MAX, two-stage sour water stripper to produce pure NH_3 and pure H_2S .

In the first option, the H_2S is sent to the sulphur recovery unit and the ammonia is sent to the fertilizer unit. In the second option, the H_2S is sent to the sulphur recovery unit and the ammonia is sent to the incinerator.

Single-stage SWS

Sour water is collected from all of the units in the facility and sent to a dedicated vessel. Sour water is received in the sour water feed drum in which water and oil are separated. Caustic NaOH is injected into the sour water line to the sour water feed drum. Any flash gas generated goes to the tail gas incinerator. The slop oil pump transfers the recovered oil to the closed drain system on high level in the oil compartment of the sour water feed drum.

The sour water tank feed pump transfers the sour water from the sour water feed drum, under level control, to the sour water feed tank. The tank is a cone-roof tank with an oil skimmer attached to an internal floating roof. It is designed for a 72-hour residence time to minimise the effects of fluctuations in the sour water composition. The tank is also provided

Fig. 1: Single-stage sour water stripping

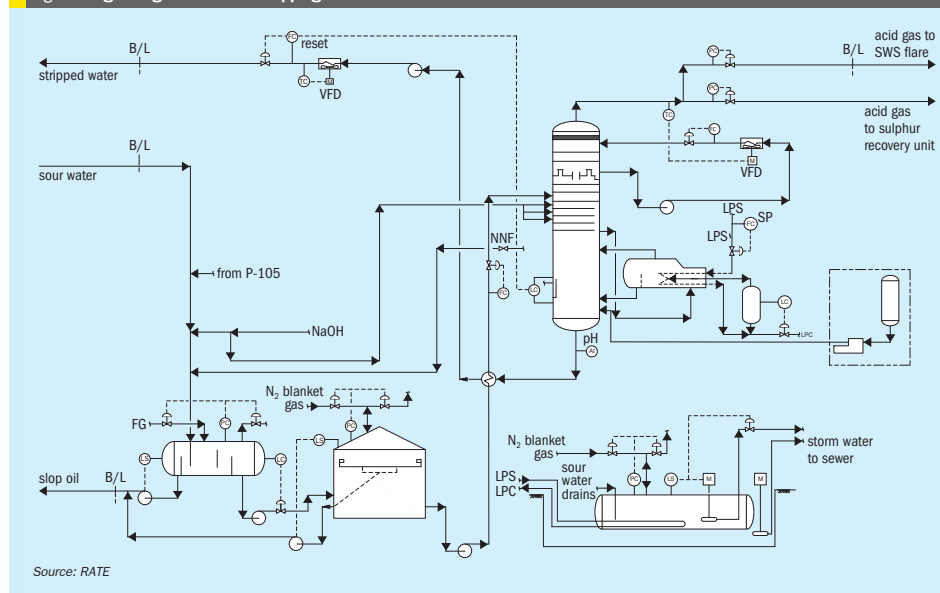

with nitrogen blanketing above the floating roof and a H_2S analyser of the nitrogen space. Skim oil separated out in the oil skimmer is sent, via skim oil pumps to the discharge line of the slop oil pumps.

The sour water stripper strips the sour water feed from the sour water feed tank. The sour water feed is first pumped with sour water stripper feed pumps and then preheated in the stripper feed/bottoms exchanger by the hot stripped water from the column. To avoid corrosion due to flashing, the feed temperature is limited to 95°C.

The stripper has a lower stripping section, and an upper pumparound section, which serves as a contact condenser for most of the stripping steam. The pumparound pump recirculates water from the top chimney tray back to top tray via the pump-around air cooler under flow control. Excess pumparound water continuously overflows the chimney tray as internal reflux. The pumparound cooler is regulated to maintain acid gas vapour temperatures no lower than 75°C to avoid gas-phase deposition of solid ammonium bisulphide (NH_4HS). The stripped gas goes to the SRU.

Low pressure steam is directly injected into the bottoms of the sour water stripper for stripping. An ammonium polysulphide

package also injects ammonium polysulphide into the bottoms of the sour water stripper.

Hot stripped water is initially cooled by heat exchange with the stripper feed in the feed/ bottoms exchanger. It is then pumped by the SWS bottoms pump for further cooling in the recovered water cooler. The bottoms flow is automatically adjusted to maintain a constant liquid level in the stripper. The cooled stripped water is returned to the unit it originated from (delayed coking unit or hydrotreating unit) outside of the battery limit. Fig. 1 shows a single-stage sour water stripper.

SWS-MAX 2-stage SWS for pure NH_3 and H_2S

SWS-MAX is a proprietary two-stage sour water stripper design by RATE.

H_2S stripping

From the feed tank, the degassed sour water is pumped to the two-stage SWS plant, where it is heated by feed bottoms exchange and fed to the acid gas or hydrogen sulphide stripper. This stripper is a steam-reboiled distillation column. The hydrogen sulphide, which is stripped

overhead, is of high purity and an excellent feed for sulphur plants. It contains negligible ammonia and, because the plant feed has been degassed, only traces of hydrocarbons. It does, however, contain any carbon dioxide that is present in the feed.

Ammonia stripping

The hydrogen sulphide stripper bottoms stream, containing all the ammonia in the feed and some hydrogen sulphide, is fed directly to the ammonia stripper, which is a refluxed distillation column. In this column, essentially all ammonia and hydrogen sulphide are removed from the water, which leaves as the column bottoms stream. After exchanging heat with the hydrogen sulphide stripper feed, this stripped water is cooled and sent off-plot for reuse or treating. The ammonia and hydrogen sulphide stripped from the water in the ammonia stripper are passed through an overhead condenser and are partially condensed.

H_2S absorption

The purpose of the H_2S absorber is to remove any additional H_2S from the rich NH_3 stream and recycle it back to the system to ensure the incineration stack complies with SO_2 emission regulations.

Ammonia incineration

Ammonia can be sold as a liquid to local fertilizer companies or burned in the incinerator.

For some plants, ammonia recovery may not be desired or may be uneconomical. In such cases, the ammonia product can be incinerated, either directly off the reflux drum or after being scrubbed with water to reduce the hydrogen sulphide content. Alternatively, it may be further purified and recovered to produce either anhydrous or aqueous ammonia suitable for sale or for further processing.

Key features of WSW-MAX are:

- Stripping the mixture of H₂S and NH₃ in a first stripping distillation column to obtain a rich H₂S vapour, which flows, to the sulphur recovery unit.
- The bottom of the stripping column contains rich NH₃ which is processed in the second tower.
- Stripping the rich NH₃ in a second stripping distillation column to obtain rich NH₃ vapour, it is purified further in the H₂S absorber to remove any residual of H₂S before sending it to the ammonia-burning incinerator or to the fertilizer unit.

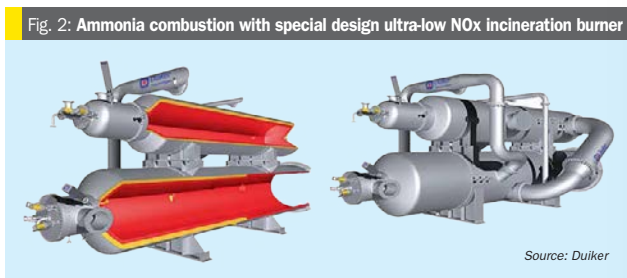

- The overhead of the H₂S absorber through the knockout drum is pure rich NH₃. The bottom of the H₂S absorber and the knockout drum containing H₂S is recycled to the first distillation tower H₂S stripper through the feed tank.
- The advantage of the two-stage column design is the separation of H₂S and NH₃ into different product streams. The ammonia stream can be combusted without producing significant SO₂, or it can be purified and sold as feedstock. Likewise, the purified H₂S can be directly used as a feedstock for a sulphuric acid plant. Besides beneficial uses, diverting NH₃ away from the SRU can improve the performance of the SRU. Ammonia can cause operating problems such as catalyst deactivation and equipment plugging in the SRU. In addition, a higher flame temperature is required to fully destroy NH₃, leading to higher CO and CS₂ formation and subsequently lower sulphur recoveries.
- The size of the SRU can be reduced or the throughput of an existing unit can be increased since the extra air required to burn the ammonia, as well as the ammonia itself, is eliminated from the feed.

Fig. 3: RATE two-stage SWS-MAX sour water stripping

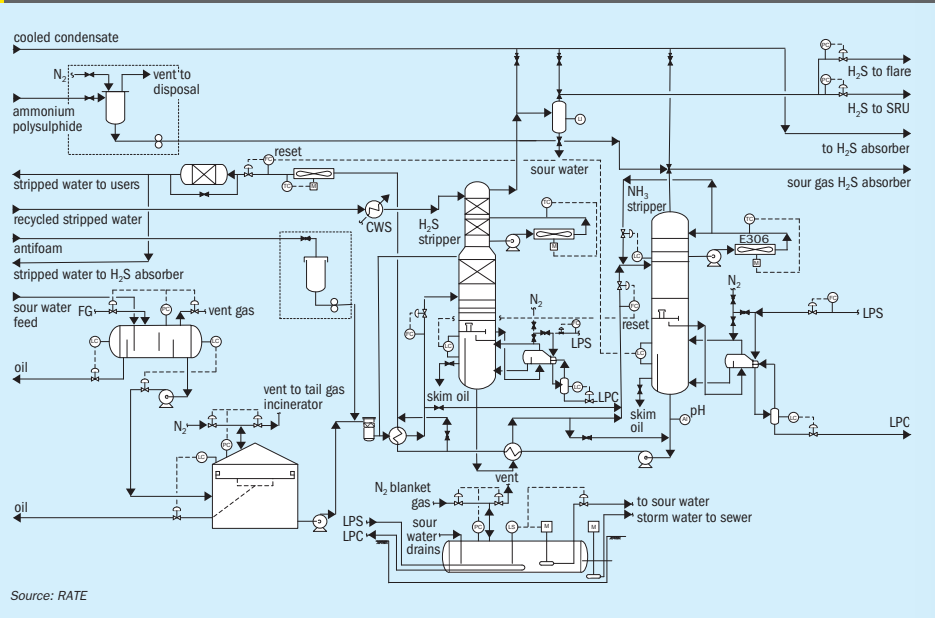

Source: RATE

Fig. 4: RATE two-stage SWS-MAX sour water stripping

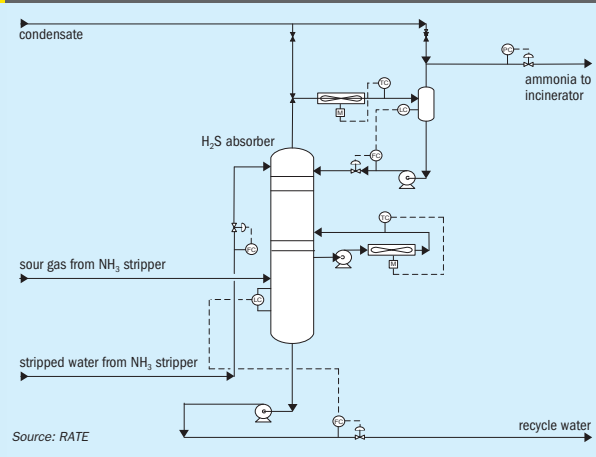

Fig. 2 shows an example of a special ultra-low NOx ammonia burning incinerator design by Duiker.

Figs 3 and 4 show the two-stage SWS-MAX proprietary design by RATE.

The H₂S absorber removes all residual H₂S to produce pure ammonia, free of H₂S, that can be incinerated compliance with SO₂ emission regulations. SWS-MAX differs from other technologies that require having caustic scrubbing to meet environmental regulations.

If the ammonia stream is to be incinerated it is sent to the incineration section, comprising a forced draft incinerator with heat recovery. The burner is a proprietary design to manage ammonia burning without any NOx formation. The ammonia will be dissociated in such a way to keep NOx at a very low level and to comply with environmental regulations.

The flue gas is cooled in a waste heat boiler by generating high pressure steam. The high-pressure steam along with the excess high-pressure steam from the SRU is superheated in the superheater coil of the incinerator waste heat boiler before being exported to the high-pressure steam header. The incinerated flue gas is routed to the stack.

Case studies of recent RATE projects

Case 1 – SRU capacity expansion

In this project, the customer had an existing sulphur recovery unit treating amine acid gas and the sour water strip-

per gas from the sour water stripper and, due to an expansion of the refinery, the SRU capacity had to be increased. Two options were evaluated: (1) increase the SRU capacity by using oxygen enrichment, or (2) eliminate the SWS gas to the SRU and increase the amine acid gas only (the sour water stripper would be modified to a 2-stage SWS scheme and the incineration would be modified to ammonia burning incineration).

The block flow diagram in Fig. 5 compares the two options.

It was concluded that the capital investment of using oxygen enrichment compared to using a two-stage SWS was compatible, but the operating cost of oxygen enrichment case was higher due to supplying the oxygen at all times. The customer therefore selected two-stage SWS over oxygen enrichment.

Case 2 – Refinery expansion resulting in corrosion problems

In this project, the customer added the coker unit to their refinery without evaluating the SWS and experienced severe corrosion in the tail gas treating unit. They tested the bottom stream of the SWS and the water contained significant amount of phenol and cyanide. The water was recycling throughout the process units when phenolic water should not be recycled as process water.

Recycling of the treated water from the SWS as process water was stopped.

The existing SWS was evaluated according to the following engineering activities:

- Conduct the SWS simulation based on the original design.
- Conduct the SWS simulation based on the current conditions with phenolic water.
- Evaluate the original equipment sizing and compare to the new condition.
- Evaluate the SWS internal designs for numbers of trays and reboiler duties.
- If feasible, recommend modifications to the existing unit.
- If modification are not possible, consider either adding an additional new SWS column in series with the existing one or, separating the phenolic water from the non-phenolic water upstream of the SWS so that the new water from the new unit will have its own SWS and the existing SWS is used for non-phenolic water.
- The overhead from both SWSs will be sent to the SRU.
- Evaluate the existing SRU to ensure an adequate combustion temperature in the burner.
- If the combustion temperature is inadequate introduce low level of oxygen.

The final recommendation was to separate and process phenolic and non-phenolic sour water separately.

Case 3 – Processing new SWS gas in an existing SRU

In this project, the existing sulphur recovery unit was not processing SWS gas. The only feed stream was the amine acid gas from the ARU unit.

Adding the SWS gas to the existing SRU would impact on the capacity if the SRU operated on air only, therefore, the amine acid gas would have to be reduced to maintain the hydraulic and capacity limits. An alternative option was to use oxygen enrichment to keep the same rate of amine acid gas and to add the new stream of the SWS gas. The system had to be modified to receive both amine acid gas and the SWS gas and using oxygen enrichment for maintaining the capacity. In addition, oxygen would increase the combustion temperature that helps with the destruction of ammonia and other contaminants from the SWS gas. Destruction of ammonia, phenol, cyanide, heavy hydrocarbons, BTEX, and mercaptans with oxygen enrichment has significant advantages and prevents the plugging of downstream equipment.

CONTENTS

What's in issue 397

COVER FEATURE 1

Sour gas projects

COVER FEATURE 2

Demand for sulphur fertilizers

COVER FEATURE 3

Options for sour water stripper gas

COVER FEATURE 4

Sulphuric acid projects and technology

SULPHUR
ISSUE 397
NOVEMBER-DECEMBER 2021

BCInsight

Southbank House, Black Prince Road
London SE1 7SJ, England
Tel: +44 (0)20 7793 2567
Fax: +44 (0)20 7793 2577
Web: www.bcinsight.com
www.bcinsightsearch.com

Fig. 5: SRU capacity expansion options

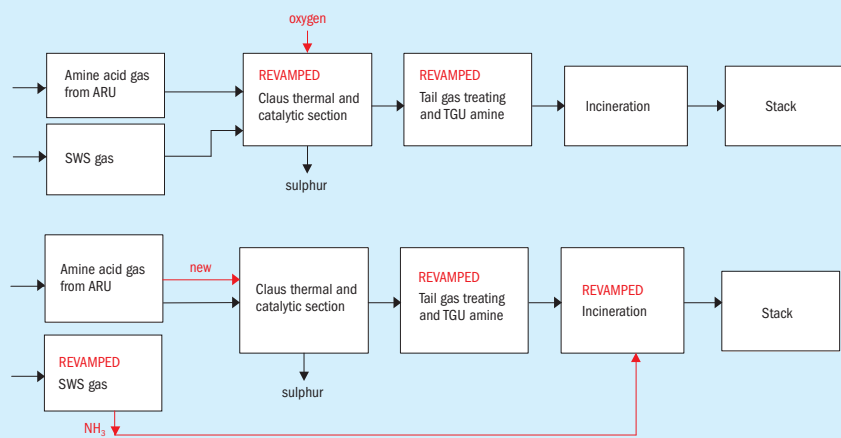

Source: RATE

Processing SWS gas in the sulphur recovery unit requires specific criteria and advanced control to ensure:

- proper amine acid gas split between zones 1 and 2 of the reaction furnace; proper air control;
- sufficiently high temperature in Zone 1 for the reaction furnace for the destruction of ammonia and other impurities;
- prevent SO₃ formation and corrosion by providing proper mixing;
 - complete destruction of SWS in feed
 - high intensity burner
 - adequate residence time in the reaction furnace
 - adequate burner combustion temperature
 - provide checker wall, vector wall or choke ring in the reaction furnace
 - partial bypass of amine acid gas to rear zone of furnace
 - steam traced ammonia acid gas lines
 - keep mixed acid gas line short
 - ammonia content in the WHB outlet less than 100 ppm.

Processing the amine acid gas and the SWS Gas with the reaction furnace configuration would require a two-zone reaction furnace (Fig. 6). Based on extensive CFD modelling the best configuration for processing amine acid gas and the SWS gas was to have a two-zone reac-

Fig. 6: Two-zone reaction furnace

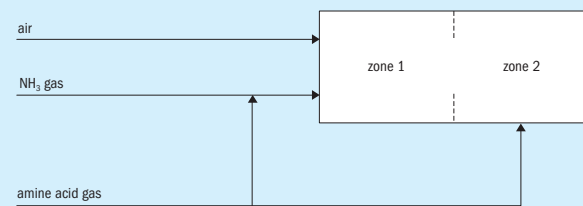

Source: RATE

tion furnace. Some licensors use a single zone reaction furnace which lacks flexibility of operation. With a two-zone reaction furnace, if there is any fluctuation in the amine acid gas, the operator can adjust the flow rate of the amine acid gas to each zone to maintain the adequate combustion temperature, with one zone this isn't an option.

In addition, using oxygen enrichment has the following requirements:

- new burner capable of ammonia burning with oxygen
- new SWS line with control system
- new oxygen line with control system
- new reaction furnace
- other equipment should be evaluated

for any necessary modifications/ replacements

- all piping pressure drop should be checked for hydraulic limits
- refractory upgrade suitable for oxygen enrichment.

Conclusions

In a grassroots design, normal practice has been to process SWS in the SRU and to have separate sour water strippers for phenolic and non-phenolic water.

When it comes to the revamp and modification of existing SRUs the best option will depend on the specific situation and the purpose of the modifications. ■

SulGas
VIRTUAL | 2022

<https://sulgasconference.com>

South Asia's
only
Conference
on Sulphur
Recovery &
Gas Treating

Meet and interact virtually with
global experts from operations,
licensors, and technology
providers.

Mark your calendars
1- 4 Feb. 2022

Register Now **KEY FOCUS**



- DECARBONISATION
- DESULPHURISATION
- DIGITISATION

Key Stats

*anticipated



20+ Countries
(India, Asia-Pacific,
Middle-East)



350+
Attendees



70+
Companies



40+
Manufacturing /
operating sites

Sponsors & Partners

Premier Sponsor



Executive Sponsors



Organizing Partner



Official Publication



Media Partners



Exhibitor



Premier, Executive, Exhibitor Sponsorship Plans Open

All plans curated to maximize digital visibility and exposure

For details: +91 7330875310 admin@sulgasconference.com

OpCo Delegates - Register for FREE Others - INR 8000 / USD 150 + GST

CONTENTS

What's in issue 397

COVER FEATURE 1

Sour gas projects

COVER FEATURE 2

Demand for sulphur fertilizers

COVER FEATURE 3

Options for sour water stripper gas

COVER FEATURE 4

Sulphuric acid projects and technology

SULPHUR
ISSUE 397
NOVEMBER-DECEMBER 2021

BCInsight

Southbank House, Black Prince Road
London SE1 7SJ, England
Tel: +44 (0)20 7793 2567
Fax: +44 (0)20 7793 2577
Web: www.bcinsight.com
www.bcinsightsearch.com

Challenges with the transition to biofuels

Considering the current shift to produce biofuels instead of conventional oil products, **M. van Son** of Comprimo discusses the impact that this may have on the ability to process the sour water acid gas streams produced in existing or new sour water strippers.



PHOTO: BANKSPHOTOS/ISTOCKPHOTO.COM

Fig. 1: Process flow scheme of single-stage sour water stripper

Source: Comprimo

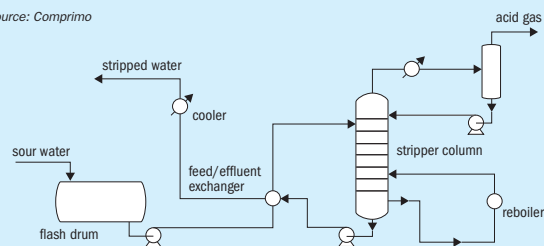

Sour water can be found in most industrial facilities including refineries, gas plants, power plants and chemical factories. Depending on the source of the water, the components in the sour water will be completely different.

In a sour gas processing facility, the sour water typically originates as either produced water or condensed water and may contain low levels of H_2S and CO_2 as well as hydrate/corrosion inhibitors. Produced water may also contain salts. Condensed sour water is normally salt free, however may contain carry-over products from the production cycle such as amines, glycols, methanol, and other items that may have been injected into the process¹.

In an oil refining facility, the sour water can originate from desalters and processing units such as the fluid catalytic cracker (FCC) or hydrotreaters as well as amine and sulphur recovery units (SRUs) including the tail gas treatment unit (TGTU). These sour water streams distinguish themselves from gas processing facility sour water streams through their higher hydrogen sulphide (H_2S) content, the presence of large amounts of ammonia (NH_3) and the much larger volumes that need to be processed.

The processing of these sour water streams in a sour water stripper has been well documented in literature^{2,3} and it is not the intent of this article to go into design details of these units or what can be done with the stripped water. The focus of this article is to discuss the impact that sour water stripping technology selection may have on the produced sour gas streams, also called sour water acid gas (SWAG), and on the options available to process these gases, considering the current shift to produce biofuels instead of conventional oil products.

Fig. 2: Process flow scheme of two-stage sour water stripper

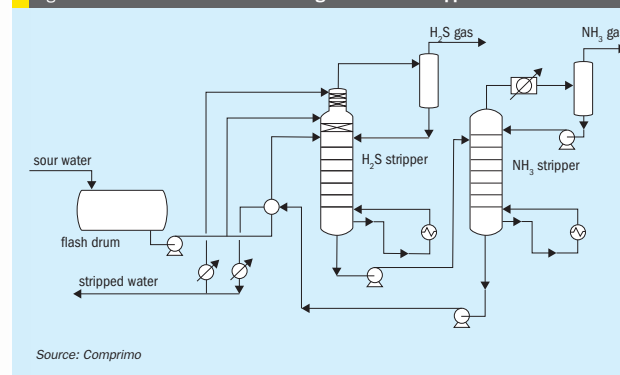

Source: Comprimo

Conventional sour water stripper acid gas processing

Sour water produced in a plant where no ammonia is present, such as a gas plant, typically contains very low concentrations of H_2S and CO_2 as neither of the gases dissolve in high concentrations in the sour water based on Henry's law. One can expect concentrations in hundreds of ppmwt. As a result, the SWAG flow rates are very small, and in most facilities will be routed to the flare directly, where they may add a small amount of SO_2 to the environmental emissions.

This is not the case in refineries where a large portion of the nitrogen present in the crude oil is converted to ammonia in the hydroprocessing units. Due to the rapid dissolution of ammonia in water and the formation of ammonium bisulphide in water, with equimolar amounts of ammonia and H_2S , the sour water will contain large amounts of ammonia and H_2S . There are usually two different methodologies for removing the H_2S and ammonia from the sour water. In Fig. 1, a typical process flow scheme for a single-stage sour water stripper is provided. This configuration removes both ammonia and H_2S from the water to produce a SWAG stream containing about one third H_2S , one third ammonia and one third water.

Some facilities may elect to segregate the ammonia and H_2S in a two-stage sour water stripper. This results in a high purity ammonia product, which can be sold as anhydrous or aqueous ammonia and a high purity H_2S product, which is processed in an SRU. Alternatively, the segregated

ammonia can be destroyed in a CO boiler or other furnace. It can also be routed as a separate feed source to the SRU, which is often the destination for SWAG from a sour water stripper in a refinery environment.

Fig. 2 shows a typical configuration for a two-stage sour water stripper.

The traditional method to process SWAG in a refinery is in the thermal stage of the SRU. Due to the potential for ammonia to form salts with H_2S , CO_2 and SO_2 in colder sections of the SRU, it is essential to destroy the ammonia to a very low concentration (<50 ppmv). This is normally accomplished in the thermal reactor by integrating the three Ts into the design: temperature, time, and turbulence. The turbulence portion can be accomplished by installing a high intensity burner to provide good mixing of the acid gas streams and air/oxygen. A minimum temperature of 1,300°C is recommended for the destruction of ammonia. This can be done by designing the SRU with air and acid gas preheat or by installing a front-side split thermal reactor, where a portion of the amine acid gas bypasses the main burner, thereby artificially raising the air stoichiometry in the front zone to provide a higher temperature. It is recommended to limit the bypass of amine acid gas to the second zone of the thermal reactor such that the front zone remains a reducing environment as oxidising conditions can impact the integrity of the refractory. And finally, time is simply a matter of residence time in the thermal reactor. It can range anywhere from 0.8 seconds to 2 seconds depending on the ammonia concentration in the mixed acid gas or the presence of hydrogen cyanide.

The impact of biofuels on how to process sour water acid gas

With the emergence of biofuels facilities, there are new challenges with respect to sour water strippers and where and how to process the sour water stripper acid gas that is produced.

There are essentially two different methods for processing biofeedstocks in refineries.

In the first method, biofeedstocks are co-processed with conventional hydrocarbon feedstocks. This results in somewhat modified SWAG streams, without much of an impact to the downstream SRU where the SWAG is processed. Similarly, the impact on the performance of a two-stage sour water stripper to segregate ammonia and H_2S is also marginal.

The second method is a standalone biofuels facility, for which the most common technology chosen nowadays is the application of hydrotreating. In this process, water is produced due to the oxygen atoms in the biomass feeding the hydrotreater, and some wash water may be required to remove any ammonia produced in the unit. As biomass is typically very low in sulphur, these sour water streams will not have the traditional equimolar ammonia and H_2S composition but will contain much higher concentrations of ammonia compared to the H_2S . These water streams may also contain a substantial amount of CO_2 . In addition to the change in the sour water composition, due to the absence of sulphur components in the feed, there is usually no large amine acid gas stream associated with the unit, which traditionally would be fed with the SWAG to the SRU. As a result, in most cases these facilities will not have an SRU, which makes the question of where and how to process SWAG more important.

So, what options are there to deal with SWAG when there is very little amine acid gas available and there is still a requirement to meet certain environmental limitations for SO_2 emissions? The key is how to deal with ammonia. Ammonia by itself is a very dangerous product with a TLV of 25 ppmv and cannot be released to atmosphere without destroying or removing it first.

Due to the presence of H_2S , even though in smaller quantities than for conventional refineries, the treatment of the SWAG will need to be combined with the removal of the H_2S before effluents can be sent to the atmosphere.

The first option discussed here is to route both SWAG and the amine acid gas

CONTENTS

What's in issue 397

COVER FEATURE 1

Sour gas projects

COVER FEATURE 2

Demand for sulphur fertilizers

COVER FEATURE 3

Options for sour water stripper gas

COVER FEATURE 4

Sulphuric acid projects and technology

SULPHUR
ISSUE 397
NOVEMBER-DECEMBER 2021

BCInsight

Southbank House, Black Prince Road
London SE1 7SJ, England

Tel: +44 (0)20 7793 2567

Fax: +44 (0)20 7793 2577

Web: www.bcinsight.com
www.bcinsightsearch.com

Fig. 3: Process flow scheme for ammonia burning thermal oxidiser with scrubber

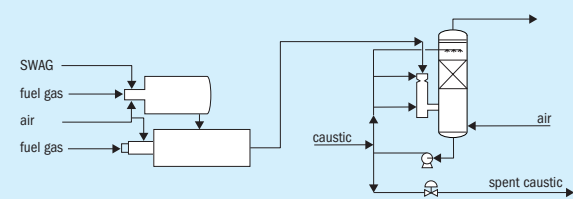

Source: Comprimo

Fig. 4: Process flow scheme for acidic removal of ammonia prior to sulphur scavenging unit

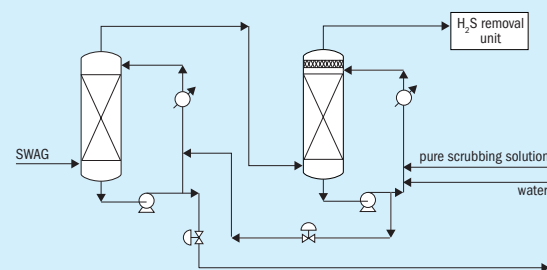

Source: Comprimo

that are produced together to a thermal oxidiser. Due to the presence of ammonia, the thermal oxidiser design needs to be modified to ensure that full ammonia destruction can occur, and the formation of NO_x is limited. This will require special thermal oxidiser technologies like the John Zink Noxidizer or the Duiker SCO technology. The custom designed thermal oxidiser employs a staged process, whereby NH₃ destruction is achieved in a reduction chamber with a high-temperature and sub-stoichiometric environment to prevent NO_x formation. The gases from the reduction chamber are quenched before entering the oxidation chamber where air is injected to complete combustion. A fire tube waste heat boiler provides heat recovery and cooling of the flue gases. Due to the presence of H₂S in the SWAG, SO₂ is produced and can be removed using a flue gas desulphurization technology, which in most cases uses caustic to meet the environmental targets. The absorbed SO₂ is typically converted to a sulphate by introducing air in the waste stream and routed to a wastewater treatment facility.

Alternative technologies such as eutectic freeze crystallisation could be considered to produce a solid product instead of a wastewater stream. Depending on the amount of sulphur present in the sour water and amine acid gas streams, the consumption of caustic in this configuration could lead to high operating costs. Fig. 3 shows the process scheme for this line up.

An alternative methodology for dealing with the ammonia in SWAG is to install an ammonia scrubbing system which is designed to remove ammonia before it is routed to an H₂S scavenging unit.

The ammonia scrubbing system consists of a dual stage absorption system designed to remove 99.9% of the ammonia from the gas stream. In this unit, the gas is passed through two towers where the gas is contacted with an acidic scrubber solution to remove the ammonia by forming ammonium bisulphate or ammonium sulphate in solution. As the H₂S in the gas phase is a weak acid, it will not be picked up by the scrubber solution, which is a strong acid. The remaining gas will contain mostly H₂S and CO₂ and can then

be processed together with the amine acid gas (if present) in an H₂S scavenging system such as LOCAT, Thiopaq or Sulfatreat. The process scheme for this solution is provided in Fig. 4.

For a biofuels facility, the primary key for processing sour water and SWAG is how to integrate the processing with the available infrastructure that may or may not be present⁴. It is always the preference to use the existing sour water stripper(s) and SRU to manage the new sour water and/or reduced SWAG flow rates. In the case of a full conversion from conventional oil processing to bio feedstock, the acid gas flows may be insufficient to maintain proper operation of an existing and likely oversized SRU. In that case, the economics of the above mentioned two configurations need to be evaluated for capex, opex and integration into existing infrastructures of caustic supply as well as ability to handle the waste streams from the units.

Conclusion

With the emergence of the (co)processing of bio feedstocks in hydrotreaters, the balance of amine acid gas and sour water acid gas produced in refineries is swinging more to the SWAG side. This results in a requirement to re-evaluate how to process this SWAG.

For co-processing, the impact on the existing sulphur block is typically limited to a debottlenecking of the existing sour water system with minimal impact on the SRU.

In standalone biofuels facilities, alternative methods may need to be explored on how to handle SWAG in combination with the required SO₂ emissions. Ammonia is the key component to deal with and, in the absence of an SRU thermal stage, requires alternative methods for removal with additional waste streams.

References

1. Stevens D. Mosher A., Ogg D: "Fundamentals of sour water stripping", Brimstone Sulfur Symposium, (Sep 2007).
2. Stevens D. Mosher A.: "Fundamentals of sour water stripping", Brimstone Sulfur Symposium, (Sep 2008).
3. Scott B.: "Processes for treating refinery sour waters", Brimstone Sulfur Symposium (Sep 1995).
4. van Son M., S. Sreejit S.: "Green fuel integration with refinery sulphur complex: a case study", Sulphur and Sulphuric Acid Conference 2019.

A new low-cost H₂S scavenger

New low-cost metal oxide solid scavengers for hydrogen sulphide (H₂S) removal from wet and dry natural gas have been developed and deployed at commercial scale. The desulphurisation process uses a proprietary sorbent chemistry to achieve a high sulphur capacity and removal efficiency. **G. Alptekin, F. Kugler and M. Schaefer** of SulfaTrap LLC describe the new technology and its performance.



A lead-lag system treating compressed natural gas, designed and fabricated by SulfaTrap LLC.

In large gas processing plants, H₂S is typically removed from the natural gas by amine solvent scrubbing. While amine wash works effectively to bring the sulphur concentration to levels acceptable for pipeline utilisation, the remaining sulphur concentration is typically too high for using the gas in chemical synthesis applications (e.g., steam methane reforming). Also, the high capital cost associated with amine scrubbing systems make their operation more suitable for large scale applications. As a rule of thumb, amine systems are cost effective for applications requiring higher than 10 t/d sulphur (Fig. 1). The solid-state sorbents are commonly used for polishing and small-scale H₂S removal (typical sulphur removal need is less than 1 t/d). Liquid scavengers (e.g., triazine) operate cost effectively in the intermediate range (1-10 t/d).

New technology

SulfaTrap LLC recently introduced the SulfaTrap™-R7 series sorbents for high performance H₂S removal. The very high sulphur uptake achieved by these sorbents and their relatively low cost enable their use in an expendable manner (the media is replaced periodically as it is saturated with the sulphur compounds). The SulfaTrap™-R7 sorbents consist of transition metal oxides that can remove the H₂S via a chemical reaction. SulfaTrap™-R7Q is an iron-based absorbent that is effective for treating "wet" gas streams containing at least 2,000 ppmv H₂O. The SulfaTrap™-R7J is a copper-based absorbent that can treat dry (or wet) gases containing as low as 0-2,000 ppmv H₂O. The reaction between the metal oxide and H₂S forms a stable metal sulphide as described by the sulphidation reaction below:

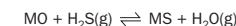

What's in issue 397

Sour gas projects

Demand for sulphur fertilizers

Options for sour water stripper gas

Sulphuric acid projects and technology

SULPHUR
ISSUE 397
NOVEMBER-DECEMBER 2021

BCInsight

Southbank House, Black Prince Road
London SE1 7SJ, England

Tel: +44 (0)20 7793 2567

Fax: +44 (0)20 7793 2577

Web: www.bcinsight.com

www.bcinsightsearch.com

Fig. 1: The effective operating range of various sulphur removal technologies

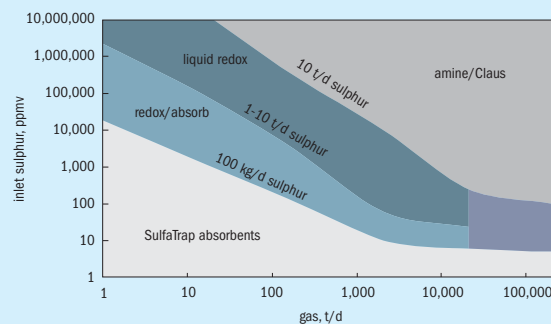

Source: SulfaTrap LLC

Fig. 2: Schematic showing the lead-lag operation (left); SulfaTrap LLC's 230 MMSCFD compressed natural gas (P=1,100 psig) desulphurisation system (right)

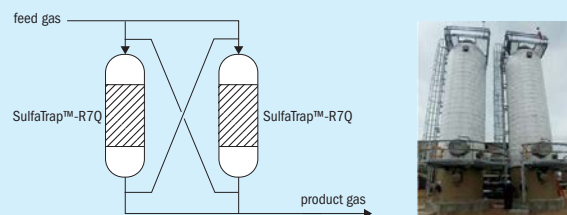

Source: SulfaTrap LLC

Fig. 3: Comparison of physical properties of SulfaTrap™-R7 sorbents for dry (left) and wet (right) gas applications

**SulfaTrap™-R7J**

Size: 3/4" to 1 1/8" pellets
 Appearance: dark grey to black
 Bulk density: 1.15 to 1.20 kg/L
 LOD (120°C): <10 wt-%
 Packaging: 150 kg drums, 24CF super sacks
 Handling: non-pyrophoric after use

Source: SulfaTrap LLC

SulfaTrap™-R7Q

Size: 3/8" pellets
 Appearance: pale red to brown
 Bulk density: 0.78 to 0.85 kg/L
 LOD (120°C): <10 wt-%
 Packaging: 150 kg drums, 24CF super sacks
 Handling: requires water spraying after use to prevent exotherm

The reaction produces one mole of water for every mole of H₂S removed which results in net water production. For process feed streams saturated with water, a condensate management strategy must be in place to prevent accumulation of liquid water in the sorbent beds. This may consist of dew point control via process heating and insulation or automatic draining of liquid water from the bottom of the sorbent vessel. The adsorption reaction is exothermic, which results in a modest adiabatic temperature rise depending on the inlet concentration of H₂S. The magnitude of the adiabatic temperature rise depends on the reactivity of the metal oxide. The expected heat of adsorption is between 30-100 kJ/mol H₂S, which corresponds to a 20-30°C adiabatic temperature rise for every 1 vol-% H₂S removed from the gas.

For best utilisation of the sorbent (i.e., to achieve the highest sulphur uptake), it is recommended that the sorbent is housed in two beds operating in lead-lag configuration, where the bed in the lead position removes the bulk of the sulphur, and the bed in the lag position serves as a polisher to reduce the outlet sulphur concentration to ultra-low levels (Fig. 2 left). Once the lead bed is saturated with sulphur, this vessel will be isolated for sorbent replacement while the lag bed provides all sulphur removal during this time. After the lead vessel is refilled with the fresh sorbent, it is placed back online in the lag position for another period of operation. This scheme allows continuous operation while maximising the sorbent utilisation. Typical changeout frequency of the sorbent is adjusted based on the site requirement (typical bed life can range from 3 to 12 months). An example of a lead-lag system treating 230 MMSCFD compressed natural gas (CNG) designed and fabricated by SulfaTrap LLC is shown in Fig. 2 (right). This system consists of two 45-m³ vessels rated for 1,100 psig.

The SulfaTrap™-R7 family sorbents maintain their mechanical integrity and physical structure after use. Both types of media can be easily removed from the vessels at the end of their useful life, either by using vacuum evacuation (directly transferring the material to a vacuum truck) or by gravity drain. As in common practice, SulfaTrap LLC recommends purging the "spent" sorbent bed with nitrogen at low pressure (after the bed is taken offline and isolated), and prior to the removal of media from the bed. The SulfaTrap™-R7Q sorbent, due to the formation of an iron sulphide phase (FeS),

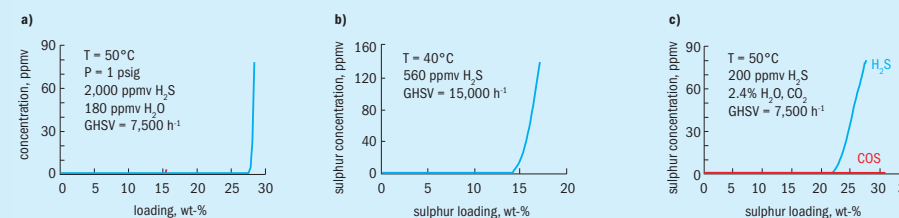
Figs 4(a-c): H₂S breakthrough profile for treatment of (a) dry natural gas over the SulfaTrap™-R7J sorbent, (b) LPG over the SulfaTrap™-R7J sorbent, (c) wet natural gas over the SulfaTrap™-R7Q sorbent

Source: SulfaTrap LLC

requires treatment with water to eliminate any potential exotherm due to exposure to air. The water quench can be applied inside the vessel housing or to the media taken outside (due to the relatively mild exotherm water can be sprayed onto the media after it is removed from the bed). On the other hand, the "spent" SulfaTrap™-R7J material is not pyrophoric after use and exposure to air does not cause any heating at all. Neither material requires activation prior to use, and both consist of inexpensive metal oxides and ceramic binders; hence can be used cost effectively in a one-through, expendable manner. A comparison of the sorbent properties is shown in Fig. 3.

The SulfaTrap™-R7J dry gas sorbent can achieve a minimum of 27 wt-% S loading at breakthrough (27 kg sulphur removed per 100 kg of sorbent). A representative breakthrough profile is shown in Fig. 4(a) for a natural gas stream containing 2,000 ppm H₂S with only 180 ppm H₂O. The gas hourly space velocity (GHSV) for the test was 7,500 h⁻¹ corresponding to a gas-

solid contact time of 0.48 sec. The sharp breakthrough profile even at such short gas-solid contact times suggests rapid sulphur uptake kinetics, resulting in excellent sorbent utilisation and high sulphur capacity in compact vessels.

SulfaTrap™-R7J sorbent can also effectively treat light hydrocarbon streams. Fig. 4(b) shows the H₂S breakthrough profile while treating a liquefied petroleum gas (LPG) stream. While in this example, the LPG is treated in the gas phase, the sorbent is equally effective when treating the LPG in liquid form. The sorbent achieves 18 wt-% S uptake at saturation.

In treating the wet gases SulfaTrap™-R7Q sorbent achieves up to 35 wt-% S uptake (35 kg of sulphur removed per 100 kg sorbent) at full saturation. A breakthrough profile for a CO₂ stream containing 200 ppm H₂S and 2.4 vol-% H₂O is shown in Fig. 4(c). This material exhibits a relatively shallow breakthrough profile, but the sulphidation kinetics is much faster (gas-solid contact time is 0.48 sec) than other iron-based commercial

sorbents. Notably, the SulfaTrap™-R7Q sorbent does not promote the formation of carbonyl sulphide (COS) in the presence of high concentrations of CO₂.

Both SulfaTrap™-R7J and SulfaTrap™-R7Q have been deployed at commercial scale with proven results treating a wide range of natural gas and LPG feedstocks in numerous sites (gas treatment plants, biogas/landfill gas treatment systems, synthesis gas desulphurisation) in the US, Canada, Europe and the Middle East.

Summary and conclusions

New metal oxide-based sorbents have been developed for removing the H₂S from hydrocarbon gas streams. The sorbent can achieve a high sulphur capacity and removal efficiency. The results from proof-of-concept experiments and field applications show that high sulphur uptake is achievable for treatment of both wet and dry gas streams with favourable economics using relatively low-cost capital systems. ■

**Watch free fertilizer market presentations**

Argus deliver concise and insightful webinars analysing the nitrogen, phosphate, potash, sulphur and sulphuric acid markets. The webinars are offered on-demand and live – and are completely free to watch.

Watch the free webinars here:
www.argusmedia.com/webinars



www.sulphurmagazine.com

www.sulphurmagazine.com

Sulphur 397 | November-December 2021

Sulphur 397 | November-December 2021

CONTENTS

What's in issue 397

COVER FEATURE 1

Sour gas projects

COVER FEATURE 2

Demand for sulphur fertilizers

COVER FEATURE 3

Options for sour water stripper gas

COVER FEATURE 4

Sulphuric acid projects and technology

SULPHUR
ISSUE 397
 NOVEMBER-DECEMBER 2021

BCInsight

Southbank House, Black Prince Road
 London SE1 7SJ, England

Tel: +44 (0)20 7793 2567

Fax: +44 (0)20 7793 2577

Web: www.bcinsight.com
www.bcinsightsearch.com

Liquid redox going beyond the expected

The Valkyrie™ process was first introduced as a reborn version of redox technology for treating H₂S in natural gas processing. In this article Streamline Innovations Inc. highlights some of the new developments and successful applications of the Valkyrie process and its redox technology, in both gas and water streams.

In *Sulphur* No. 387 March-April 2020, pages 46-52, Streamline Innovations Inc. introduced the Valkyrie™ process as a reborn version of redox technology for treating H₂S in natural gas processing. The Valkyrie process is a derivation of the original liquid redox process in which the chemical, Talon™, converts hydrogen sulphide (H₂S) into elemental sulphur in a reduction reaction and regenerates when exposed to oxygen from air in the oxidation process. With a high specificity towards sulphides and a fast reaction rate, the Valkyrie process provides the efficiency of a scavenger with a significantly lower opex due to its regenerative chemistry.

The primary chemistry of the Valkyrie process, Talon, was designed to be environmentally forward and biodegradable. The recent rise in ESG and zero-flare initiatives has made its green characteristics an attractive alternative to hazardous triazine-based scavengers in the upstream oil and gas market, specifically in the U.S. shale gas sector.

Since 2018, Streamline has deployed 20 Valkyrie systems, with nearly a dozen more in development, and has expanded its technology to industries beyond upstream natural gas processing. Since the process is agnostic to the carrier gas (natural gas, CO₂, air, N₂, water), applications in landfill gas, renewable fuels, municipal and industrial wastewater treatment, and aerobic foul air scrubbing have all been added to Streamline's repertoire.

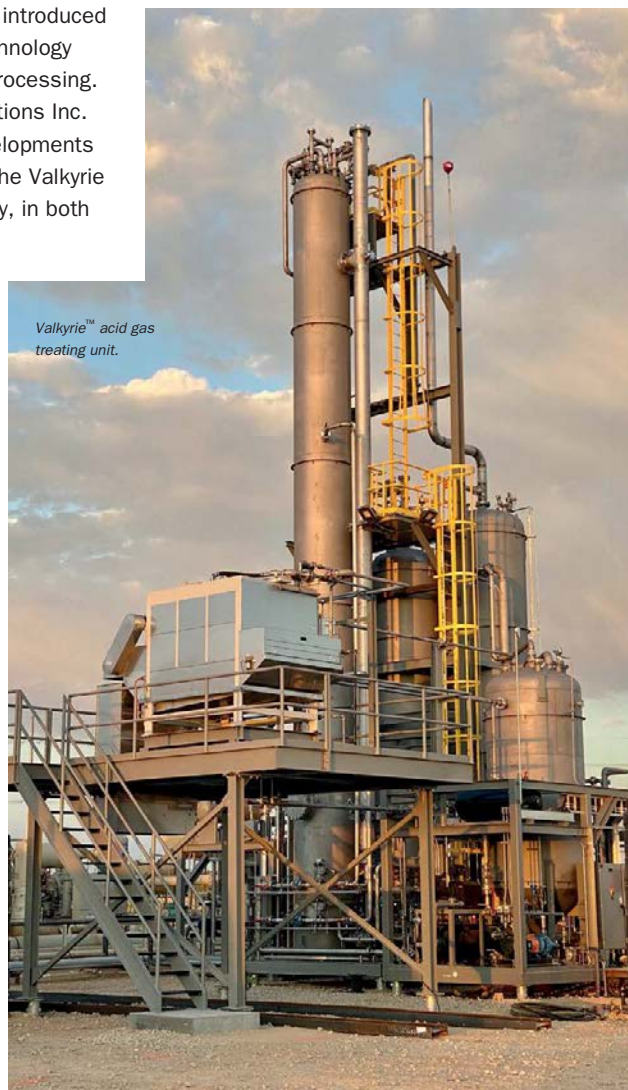

Valkyrie™ acid gas treating unit.

PHOTO: STREAMLINE INNOVATIONS

In parallel to its gas-based applications, water-based Talon is equally robust and efficient to treat dissolved sulphides in water and wastewater streams. In these aqueous applications, hydrogen peroxide, rather than oxygen, is generally used as the oxidation source due to its efficiency and ease of application. Streamline has commercialised and deployed its Talon Sulphide Elimination System (TSES), which provides a flexible process that destroys the underlying sulphide in the aqueous phase in either lead or lag configurations, providing odour control and preventing H₂S off-gas scenarios in wastewater.

Some of the new developments and successful applications of the Valkyrie and its redox technology, in both gas and water streams are highlighted.

Acid gas treating

An oil and gas exploration and production operator in the Delaware Subbasin of the Permian in West Texas discovered its gas contained higher than expected H₂S. This region of the basin typically produces a higher gas-to-liquid ratio resulting in large gas volumes. Surprisingly, the operator found the gas containing a moderate level of H₂S, ranging from 300 to 700 ppm, and a CO₂ concentration ranging from 2% to 3%. With only 'sweet gas' pipelines available, the producer was required to treat to a maximum of 4 ppm of H₂S and 2% of CO₂. The decentralised production infrastructure (with three separate gathering facilities) and the total production of sulphur (2-4 long t/d total) meant that the construction of a Claus plant was not an economically feasible option, leaving the producer to initially assume that a scavenger would be the only practical sweetening solution available. However, the H₂S concentrations continued to increase as more wells were drilled, and with no sour gas sales pipeline available, the scavenger-based treatment quickly proved economically unsustainable.

Streamline performed a cost-benefit analysis and determined that with the previous investment in NACE-capable compression, combined with the high volume of gas and moderate level of H₂S, the optimal treating configuration was to separate the H₂S and CO₂ with an amine plant at pipeline pressure, followed by removal of the H₂S from the acid gas utilising a Valkyrie unit. The resulting unit, called "Super-Valkyrie", is an integrated smart amine plant directly coupled with a Valkyrie acid

gas treating unit (Valkyrie AGTU).

Three units were constructed in parallel. Each unit was designed to treat 60 MMSCF/D at 900 psig on the 50 gpm amine plant, with a 1 long t/d Valkyrie AGTU. The Valkyrie AGTU was modified from the direct treat Valkyrie to treat the acid gas stream with H₂S concentrations ranging from 35% to greater than 50%. The design allows the desulphurised acid gas stream of nearly pure CO₂ and water vapour to be sent to a small flare – without H₂S present, dropping emissions of SO₂ to below levels requiring Title V air permitting regulations.

Unique aspects of the Valkyrie AGTU include the following:

Balance between low operating pressure and high H₂S in acid gas: The Valkyrie AGTU was designed to treat the extremely high H₂S of acid gas at much lower operating pressure than a standard direct treat Valkyrie operating at field pressure. Because liquid redox treating is purely chemically driven and therefore less dependent on pressure of the gas, the primary design consideration was to balance the height of the Valkyrie contactor (required to provide enough reaction time) versus the amine overhead still pressure, which generates the head pressure required to overcome the liquid head in the Valkyrie contactor. A balance was achieved between increasing the pressure of acid gas off the amine still and the design of the contactor to achieve the desired treating units required to meet the outlet acid gas spec of <4 ppm of H₂S.

Temperature considerations due to high H₂S exothermic reaction: Liquid redox treating of H₂S creates an exothermic reaction. When treating extremely high H₂S in acid gas, there is a significant reaction resulting in an increase in process chemistry temperatures of over 25°F. Design considerations for this temperature increase included process coolers, elimination of insulation to allow cooling from ambient air, and improving the efficiency of the reaction with a novel patent-pending contactor design.

Smart amine integration with Valkyrie AGTU: To ensure seamless operation of the SuperValkyrie process, the process control logic of the amine needed to not just maintain temperature of the amine in the regeneration still, but also the pressure to ensure the gas can make its way through the Valkyrie contactor and out to the flare. This required some additional logic in the unit; future approaches will

include model predictive control of the amine plant to provide efficient and automated operations. Additionally, logic was required to optimise the extent-of-reaction control in the Valkyrie unit that is crucial to the process; thus, integrated communications between the two units were required. For example, the Valkyrie unit predicts the outlet H₂S concentration of the amine plant in advance to correct for treatment rates before the additional H₂S even makes it to the tail gas treater.

Treating non-H₂S sulphur species

Generally, upstream oil and gas operators in U.S. shale are only concerned with treating H₂S in order to meet sulphur specs for the sale of natural gas into pipelines. Therefore, treating non-H₂S sulphur species does not play into facility design, and often presents a post start-up challenge to operators. Treating these sulphur species can be difficult and many times require multiple processes to achieve success.

Whilst Talon is designed for hydrogen sulphide treatment, the highly reductive nature of the chemistry will also reduce other sulphur species, notably aryl sulphides (including COS), short-chained mercaptans, thiophenes, and even carbon disulphide. The resulting products are presumably disulphides that are eliminated with the elemental sulphur generated from the H₂S.

A recent study in a gas containing significant fractions of mercaptan and other sulphur species being treated in a direct treat Valkyrie unit was performed and determined that carbonyl, methyl, and ethyl mercaptans were 95%+ removed from the gas stream, as well as a significant reduction in the corresponding sulphides. Thiophenes and CS₂ were also reduced in the gas stream (see Fig. 1).

These sulphur species would otherwise present problems to the operator, or the corresponding midstream treatment facility.

Ultra low pressure packed tower treating

With the current trend towards renewable energy and the number of landfill gas, biogas, biofuel, and renewable fuel refineries increasing daily, adaptation of treating and production facilities must occur to match new design considerations. Many of these "non-geologic" gas production sources produce smaller volumes of gas and operate at pressures far below, what

CONTENTS

What's in issue 397

COVER FEATURE 1

Sour gas projects

COVER FEATURE 2

Demand for sulphur fertilizers

COVER FEATURE 3

Options for sour water stripper gas

COVER FEATURE 4

Sulphuric acid projects and technology

SULPHUR
ISSUE 397
NOVEMBER-DECEMBER 2021

BCInsight

Southbank House, Black Prince Road
London SE1 7SJ, England

Tel: +44 (0)20 7793 2567

Fax: +44 (0)20 7793 2577

Web: www.bcinsight.com
www.bcinsightsearch.com

Fig. 1: Reduction of sulphur species in a direct treat Valkyrie™ unit

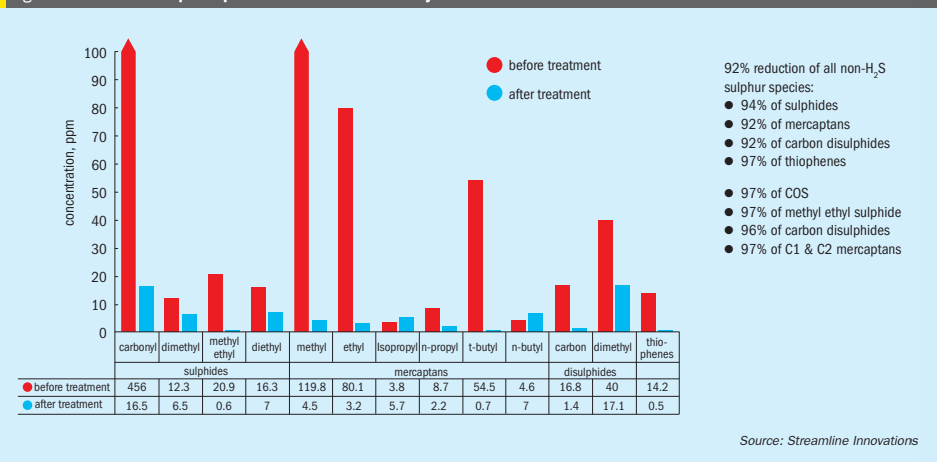

is seen in the oil and gas industry. As such, there is no appreciable pressure for the gas to transit production facilities.

Additionally, and perhaps most notably, virtually every non-geologic gas production has some level of H₂S. Achieving a low-pressure solution with a high sulphide removal capacity is imperative for these green energy sources. Talon, with its strong affinity for H₂S even at low partial pressures, its biodegradability, and non-hazardous byproducts of elemental sulphur and water, is an ideal candidate for these applications. Utilising the sulphur for agricultural soil amendment even contributes to the 'circular economy'.

Towards that end, Streamline has adapted its Valkyrie process to these applications. A small test unit is currently in operation treating approximately 30 lbs of sulphur per day at a small landfill in a pilot project, treating from 3,100 ppm to non-detectable levels, through a packed-tower system operating at 1 psig.

That project led to the construction of a large-scale plant at one of the busiest landfill sites in the U.S. situated in Northern Illinois. This unit contains a 70 ft tower with two sections, one containing a 25 ft packed tower and one as a gas-liquid separator. This system treats 7,500 scfm or 10.8 MMSCFD of gas at H₂S levels ranging from 2,500 ppm to 5,000 ppm and is expected to come online by the end of 2021. The landfill gas gathering system operates with the assistance of a com-

pression system that will pull 60 inches of H₂O with an output of approximately 4 psig, and the unit will only require a pressure drop of less than 1 psi. This outlet pressure will allow the gas to be recompressed using a non-NACE compressor to undergo membrane separation to remove the CO₂ and upgrade the gas to sales pipeline spec.



Packed tower installation.

Sour water treating

Streamline's Talon™ is equally effective at destroying sulphides in both the water phase and gas phase. At low pH, sulphide ions (sometimes called hydrosulphide, bisulphide, or HS⁻) can bind to free protons in water and release gaseous H₂S in the surrounding air. Commonly called 'sour water' in oil and gas processing and refining, sulphides are also regularly found in municipal and industrial wastewater. Streamline's Talon is designed to eliminate the sulphides before this reaction can occur and volatilise into H₂S.

The biodegradable redox chemistry is deployed in the aqueous phase through the Talon Sulphide Elimination System™ (TSES) where it breaks apart the sulphide in the same manner as in gas phase. The HS⁻ in the sour water reacts with the Talon reagent where it first undergoes reduction, converting the HS⁻ to hydrogen ions and sulphur, followed by oxidation and regeneration, through the application of an oxidant, generally hydrogen peroxide (Fig. 2). Hydrogen peroxide is a preferred oxygen source due to its ease of application as a liquid and its efficiency in reacting with Talon for the regeneration. The reactions are:

Reduction:

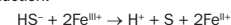

Oxidation:



Overall:

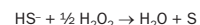
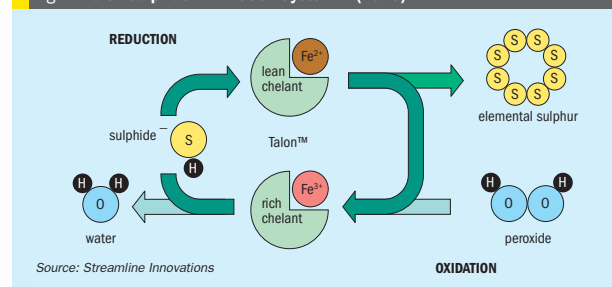

Fig. 2: Talon Sulphide Elimination System™ (TSES)



This process occurs nearly simultaneously in the same liquid stream, and therefore the application can be done in a pipeline setting, until all of the oxidant is consumed. The Talon-peroxide combination can also be very effective in more advanced processes, such as those used for reducing other organics and metals when little or no sulphides are present. When dosed correctly, the TSES will eliminate more than 95% of the sulphides in the first few minutes and will continue its redox reaction until no sulphides are remaining.

The TSES can be deployed across a range of applications including inline treating or after the water has been stored in a tank or pit. The TSES can also be deployed in a very simple manner or automated for flow pacing. In most applications, the sour water, Talon, and peroxide mixture flows through a pipeline or a reaction vessel where sufficient time is provided for the

reaction to progress to completion. In automated systems, pH and ORP analysers will compare the oxidation-reduction potential, along with H₂S analysers to ensure that sufficient chemicals have been added to completely destroy the sulphides. The sulphur formed in the reaction is a solid with an average particle size of 25 microns.

With automated analysers reading H₂S, pH, ORP, and a flow meter, the data is used in a feedback loop to determine the quantity of Talon and peroxide necessary to react with the sulphides present in the water. Talon is injected into the water stream from a chemical storage vessel and is pumped using a metering pump into the sour water pipe through an injection quill. After adding the Talon reagent, hydrogen peroxide is likewise injected from its storage vessel using a chemical metering pump into the sour water pipe through a similar quill. The mixture then requires

agitation to ensure proper contact between the chemistry and the sulphides. In certain cases, a static mixer or inlet side of a pump can maximise chemical contact with the sulphide.

Depending on the system configuration, the sulphur and any other oxidised precipitants can either be removed as part of a larger solids management program or direct filtration. If settled, the sulphur generally sinks to the bottom of the pit; in other cases, it rises with floating scum. The removal of the elemental sulphur solids can be accomplished by running the treated water through a self-cleaning back wash filter with dewatering box for the filtered solids. The filter is automated and can be spared for continuous operation.

Since the process relies on a straightforward chemical reaction, the equipment required for the TSES process is relatively simple, notably storage tanks for the Talon and peroxide, corresponding chemical injection pumps and quills, and instrumentation for reaction monitoring. This low-cost H₂S alternative provides an efficient yet cost-effective method to remove sulphides in water.

There are a number of projects in which Streamline is deploying this technology, and the applications range from wastewater in industrial applications, produced water in upstream environments, and refinery wastewater. One of note is at a Claus SRU in the Middle East, where treatment has been successful in treating 500 ppm sulphides in a water stream down to non-detect levels.

Fig. 3: TSES process for sulphide removal

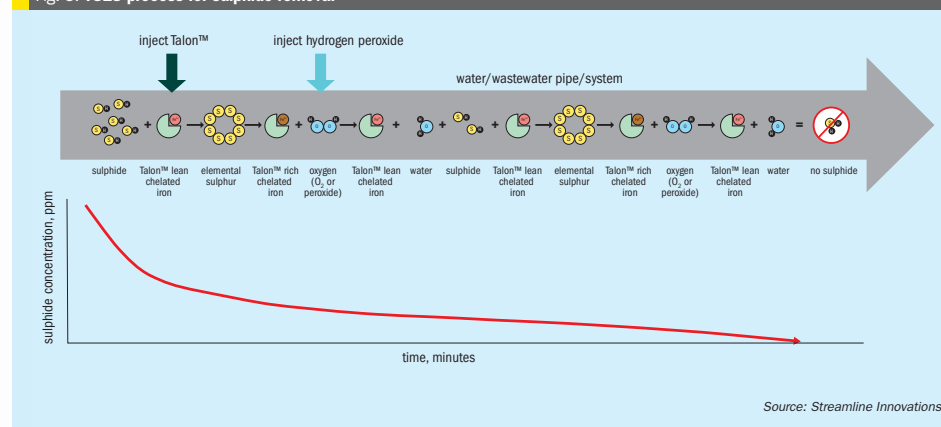

Advertisers' index

Editor: RICHARD HANDS
richard.hands@bcinsight.com

Technical Editor: LISA CONNOCK
lisa.connock@bcinsight.com

Contributor: MEENA CHAUHAN
meena.chauhan@argusmedia.com

Publishing Director: TINA FIRMAN
tina.firman@bcinsight.com

Subscription rates:
GBP 440; USD 880; EUR 680

Subscription claims:
Claims for non receipt of issues must be made within 3 months of the issue publication date.

Sales/Marketing/Subscriptions:
MARLENE VAZ
Tel: +44 (0)20 7793 2569
Fax: +44 (0)20 7793 2577
marlene.vaz@bcinsight.com
Cheques payable to BCInsight Ltd

Advertising enquiries:
TINA FIRMAN
tina.firman@bcinsight.com
Tel: +44 (0)20 7793 2567

Previous articles from *Sulphur* from 1995 to the present are available digitally in PDF format. To make a purchase, or for a list of available articles, please see: www.bcinsight.com

Copyright:
Issued six times per year, or bi-monthly. All rights reserved. No part of this publication may be reproduced, stored in a retrieval system or transmitted in any form or by any means – electronic, mechanical, photocopying, recording or otherwise – without the prior written permission of the Copyright owner.

ISSN: 0039-4890

Design and production:
JOHN CREEK, DANI HART



Printed in England by:
Buxton Press Ltd
Palace Road, Buxton, Derbyshire, SK17 6AE

© 2021 – BCInsight Ltd

BCInsight

Published by: BCInsight Ltd
China Works, Unit 102,
100 Black Prince Road,
London SE1 7SJ, UK
Tel: +44 (0)20 7793 2567
Fax: +44 (0)20 7793 2577
Web: www.bcinsight.com
www.bcinsightsearch.com

Advertiser	Page	Website
Argus Media	49	argusmedia.com
Clark Solutions	9	clarksolutions.com
Desmet Ballestra SpA	29	desmetballestra.com
HUGO PETERSEN GmbH	OBC	hugo-petersen.de
Industrial Ceramics	25	industrialceramics.com/
IPCO Germany GmbH	IFC	IPCO.com
Köppern GmbH & Co. KG	37	koepfern.de
SOGAT 2022	IBC	sogat.org
SulGAS 2022 Conference	43	sulgasconference.com
Weir Minerals	15	global.weir/brands
Worley Netherland (Comprimo)	5	advisian.com

Next issue: January/February 2022

**Distribution at:
SulGas 2022 – virtual conference**

- Sulphuric acid plant revamping
- Amine solvent swaps – switching to higher performance solvents
- US import duties and the impact on phosphate markets
- Refineries and the energy transition
- Sulphur in Central Asia

Closing date for advertisement space booking is 11 January 2022
For further information and to book advertisement space contact:
Tina Firman, Publishing Director: tina.firman@bcinsight.com
Tel: +44 (0)20 7793 2567 Fax: +44 (0)20 7793 2577

www.sogat.org
SOGAT
January 23-25, 2022
ABU DHABI **Live in-Person**

SOME OF THE TOPICS TO BE DISCUSSED AT SOGAT 2022

- Sour Oil & Gas International and National Developments
- Decarbonizing Natural Gas Processing towards Net-Zero Future
- SRU Best Practices, Experiences and Troubleshooting
- Hydrogen Production from H2S
- CO2 Capture in Gas Processing
- H2S and CO2 Recovery from Waste Streams
- HSE Considerations in Sour Hydrocarbon Management
- Role of Digitalization in Sour Hydrocarbon Management and Emission Reduction

SOME OF THE ORGANISATIONS PARTICIPATING IN SOGAT 2022



Official Publication:

SULPHUR

Organised by:

دوم للمعارض
DOME
EXHIBITIONS

CONTENTS

What's in issue 397

COVER FEATURE 1

Sour gas projects

COVER FEATURE 2

Demand for sulphur fertilizers

COVER FEATURE 3

Options for sour water stripper gas

COVER FEATURE 4

Sulphuric acid projects and technology

SULPHUR
ISSUE 397
NOVEMBER-DECEMBER 2021

BCInsight

Southbank House, Black Prince Road
London SE1 7SJ, England
Tel: +44 (0)20 7793 2567
Fax: +44 (0)20 7793 2577
Web: www.bcinsight.com
www.bcinsightsearch.com

1
2
3
4
5
6
7
8
9
10
11
12
13
14
15
16
17
18
19
20
21
22
23
24
25
26
27
28
29

ADVANCING TOGETHER

Don't forget the next issue of **Sulphur** January/February 2022



CONTENTS

What's in issue 397

COVER FEATURE 1

Sour gas projects

COVER FEATURE 2

Demand for sulphur fertilizers

COVER FEATURE 3

Options for sour water stripper gas

COVER FEATURE 4

Sulphuric acid projects and technology

SULPHUR
ISSUE 397
NOVEMBER-DECEMBER 2021

BCInsight

Southbank House, Black Prince Road
London SE1 7SJ, England
Tel: +44 (0)20 7793 2567
Fax: +44 (0)20 7793 2577
Web: www.bcinsight.com
www.bcinsightsearch.com



HUGO PETERSEN GmbH
Rheingaustrasse 190-196
65203 Wiesbaden
Tel. +49 (611) 962-7820
Fax +49 (611) 962-9099
contact@hugo-petersen.de

WWW.HUGO-PETERSEN.DE

A subsidiary of
C·A·C
Chemicalanlagenbau Chemnitz GmbH